



ST Math
Texas

Grade 5

ST Math Practice Book

Whose book
is this?

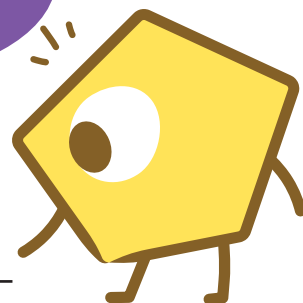

Building Mathematical Progressions Within and Across Grade Levels

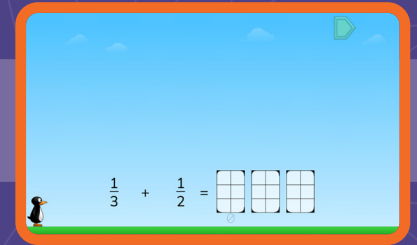
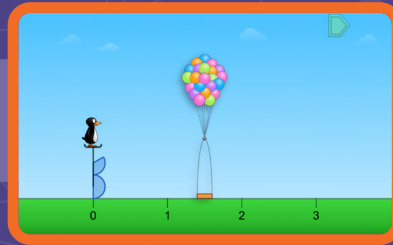
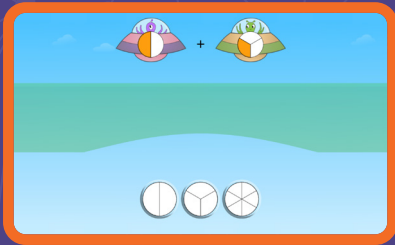

Multiple models for every concept within a grade level

Visual-First Learning That Makes Math Click

ST Math Texas is built around a patented visual-first approach that helps students see and understand math. Interactive visuals activate students' spatial-temporal reasoning, building deep understanding even before introducing formal language or procedures.

These scaffolded models support problem-solving, strategy sharing, and big-picture thinking—making math feel coherent and connected across and within grade levels.

To deepen learning, lessons use multiple representations—visuals, numbers, words, and symbols—helping students form a rich network of ideas they can apply to new problems.

With **ST Math Texas** students go beyond memorization. They develop a connected understanding of math concepts, apply their learning flexibly, and build lasting confidence.

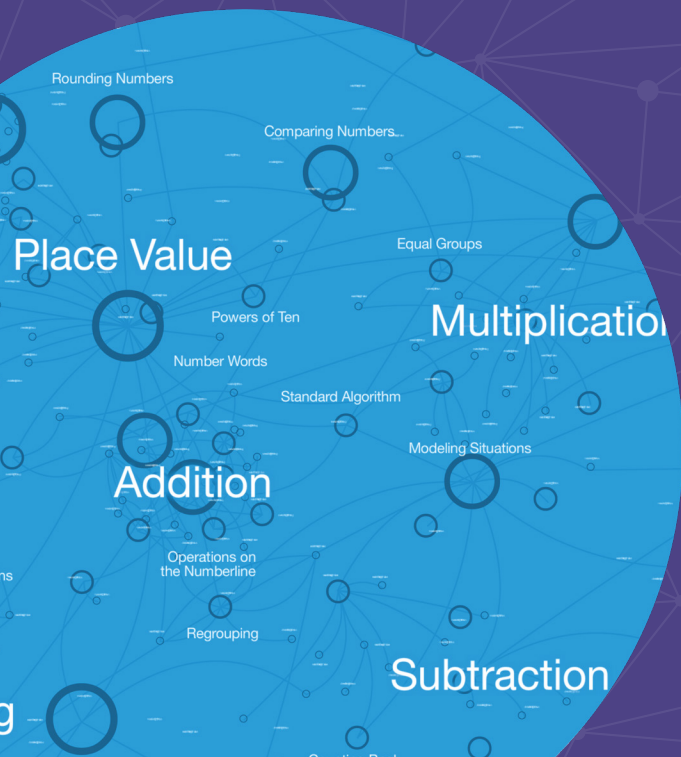

Expressions
Grade 5

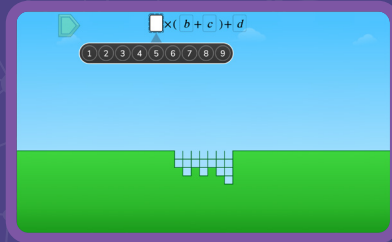

Fractions
Grade 4

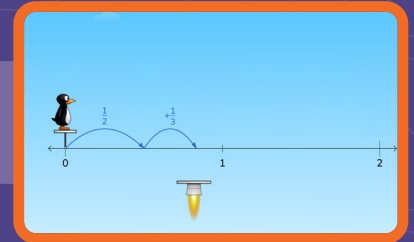
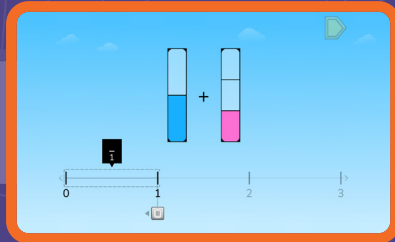

Multiplication
Grade 3

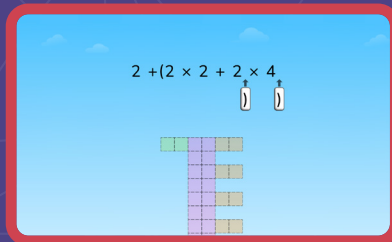

Subtraction
Grade 2

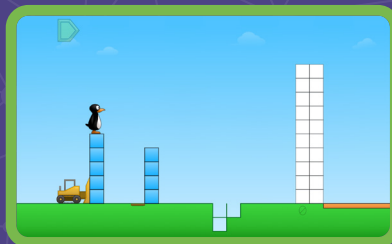

Addition
Grade 1

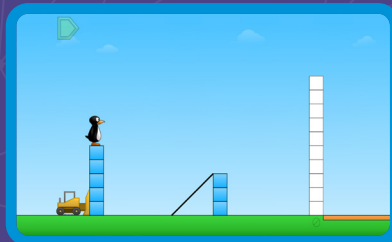

Counting
Grade K

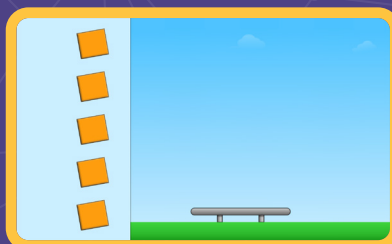

Connected visual
models build in
complexity across
grade levels

©2026 by MIND Education. All rights reserved.

No part of this work may be used or reproduced in any manner whatsoever without the written permission of MIND Education.

MIND Research Institute
5281 California Avenue, Suite 300
Irvine, CA 92617

How to Use This Document

This practice book is a standards-based, year long practice book companion to ST Math Texas.

To use this book in conjunction with ST Math Texas, find the digital games and objectives tied to each Topic. The hyperlinks will take you to the page that allows you to assign the ST Math Texas Objectives that go along with these practice pages.

These pages are designed to be printed and solved with paper and pencil. They come with spiral review, related topics and problems, and world problems that connect to the world around us.

Our help site offers further ties between ST Math, this practice book, and your school or district's curriculum.

Content Overview

In **Topic 1 (Extending Place Value, Addition, and Subtraction with Decimals)** students extend their understanding of the relationship between adjacent place values in whole numbers to decimals. They use this understanding to also extend their strategies for addition and subtraction to decimals, to explore the impact of multiplying and dividing by powers of 10, and to make sense of conversions between topics in the metric system. They extend this understanding of place value and powers of 10 to multiply and divide multidigit whole numbers in **Topic 2 (Extending Multiplication and Division to Multidigit Whole Numbers)** using the standard algorithms.

In **Topic 3 (Exploring Multistep Problems)**, students grow in their ability to interpret, represent, and solve multistep problems using symbolic notation and the convention order of operations. They extend their schema of equivalence to numerical expressions and explore the concept of “simplifying” expressions.

Topic 4 (Exploring Two- and Three-Dimensional Space) challenges students to think about and quantity size in three-dimensions: length (one dimension), area (two dimensions), and volume (three dimensions) while thinking about how the base unit, square unit, and cubic Topic are used in each case. They use area and volume as models to identify factors and to understand prime and composite numbers.

The next pair of topics addresses operations with fractions: first addition and subtraction (**Topic 5, Extending Equivalence, Addition, and Subtraction to Fractions**), then multiplication and division (**Topic 6, Extending Multiplication and Division to Fractions**). Addition and subtraction strategies are rooted in conceptual understanding: they can only be added or subtracted if they are expressed with the same-sized parts. In Topic 6, students rely on both interpretations of multiplication (iteration of a fraction or finding the fractional part of another number) and division (dividing a fraction into a whole number of parts, or determining how many fractional parts fit into a whole number).

Topic 7 (Extending Multiplication and Division to Decimals) builds on students' understanding of operations with both whole numbers and fractions. Students rely on extensions of place value patterns and/or fraction operations to interpret word problems and develop reliable strategies to multiply and divide decimals.

Topic 8 (Expanding Financial Literacy) provides students to practice computation and problem solving with decimals in money contexts while students learn about taxation and budgeting.

In **Topic 9 (Organizing Two-Dimensional Space)**, students expand their understanding of classification and come to understand classification of shapes as hierarchical. They are also introduced to the coordinate plane as a tool for quantifying location in two-dimensions. In **Topic 10 (Exploring Relationships in Data)**, students begin to use the coordinate plane to model inputs and outputs, identify patterns in data and graphs, and interpret them in real-world contexts. They make connections between algebraic and graphical representations, laying a foundation for working with and graphing algebraic equations in the future.

Topic 1: Extending Place Value, Addition, and Subtraction with Decimals

ST Math Objectives: Decimal Place Value, Rounding Decimals, Comparing with Decimals

TEKS: 5.1.A 5.1.B 5.1.C 5.1.D 5.1.E 5.1.F 5.1.G 5.2.A 5.2.B 5.2.C 5.3.A 5.3.D 5.3.E 5.3.F 5.3.G 5.3.K 5.7.A

ELPS: 1.B 1.C 1.E 1.F 2.A 2.B 2.C 2.D 2.E 2.F 3.C 3.F 3.G 3.H 4.A 4.B 4.C 4.E 4.F

Extending Place Value to Thousandths.....	7
Representing Decimals in Multiple Forms.....	8
Investigating Multiplicative Comparisons with Different Unit Wholes.....	9
Composing and Decomposing Decimals Using Place Value...	10
Comparing Decimals with Number Lines.....	11
Comparing and Ordering Decimals to the Thousandths Place	12
Rounding Decimals Through the Thousandths.....	13
Adding and Subtracting Decimals with Place Value Strategies....	14
Solving Word Problems Involving Decimal Addition and Subtraction.....	15
Discovering Patterns in Repeated Multiplication and Division by 10.....	16
Exploring Multiplicative Comparisons with Powers of Ten.....	17
Converting Between Units of Metric Length.....	18
Solving Word Problems Involving Metric Measurements.....	19

Topic 2: Extending Multiplication and Division to Multidigit Whole Numbers

ST Math Objectives: Multiplication Algorithm, Whole Number Division, Prime and Composite Numbers

TEKS: 4.1.D 4.1.E 5.1.A 5.1.B 5.1.C 5.1.D 5.1.E 5.1.F 5.1.G 5.3.A 5.3.B 5.3.C 5.3.G 5.7.A

ELPS: 1.C 1.D 1.E 2.A 2.B 2.C 2.D 2.E 2.F 3.D 3.E 3.G 3.H 4.A 4.B 4.C 4.E 4.F

Exploring Zero Patterns with Multiples of 10.....	21
Using Place Value to Multiply Multidigit Numbers by Two-Digit Numbers.....	22
Multiplying with the Standard Algorithm.....	23
Solving Open-Ended Problems with the Standard Algorithm..	24
Introducing Fractions as Division.....	25
Exploring Division with Mixed Number Quotients.....	26
Interpreting Remainders in Context.....	27
Exploring Division Strategies with One-Digit Divisors.....	28
Using Place Value Strategies to Divide by Multiples of 10.....	29
Dividing by Two-Digit Divisors.....	30
Solving Division Word Problems with Remainders.....	31
Using Multiples of Two-Digit Divisors to Divide.....	32
Solving Problems Involving Customary Unit Conversions.....	33

Topic 3: Exploring Multistep Problems

ST Math Objectives: Interpret Expressions, Patterns and Relationships, Converting Measurements

TEKS: 5.1.A 5.1.B 5.1.D 5.1.E 5.1.F 5.1.G 5.3.B 5.4.B 5.4.E 5.4.F 5.4.H 5.7.A

ELPS: 1.A 1.D 1.E 1.F 2.E 2.F 3.B 3.D 3.E 3.F 3.H 4.A 4.B 4.C 4.E 4.F

Relating Models and Expressions with Parentheses.....	35
Representing Multistep Equations with Parentheses.....	36
Relating Expressions, Models, and Words.....	37
Using Order of Operations to Simplify Expressions.....	38
Simplifying with Nested Parentheses.....	39
Solving Multistep Area Problems.....	40
Solving Multistep Problems with All Four Operations.....	41
Representing Multistep Situations with Strip Diagrams and Equations.....	42
Choosing Operations to Represent Situations with Equations...	43

Topic 4: Exploring Two- and Three-Dimensional Space

ST Math Objectives: Volume, Shapes and Properties, Prime and Composite Numbers

TEKS: 5.1.A 5.1.B 5.1.C 5.1.D 5.1.E 5.1.F 5.1.G 5.4.A 5.4.F 5.4.G 5.4.H 5.6.A 5.6.B

ELPS: 1.A 1.B 1.E 1.F 2.A 2.B 2.C 2.D 2.E 2.F 3.A 3.B 3.C 3.G 3.H 4.A 4.B 4.C 4.E 4.F

Finding the Area and Perimeter of Rectangles and Squares....	45
Discovering Prime Numbers Through Factor Pairs.....	46
Determining Prime and Composite Numbers.....	47
Using Multiples to Generate Prime Numbers.....	48
Solving Multistep Problems with Area and Perimeter.....	49
Exploring Volume of Solid Figures.....	50
Exploring Volume of Containers and Solid Figures.....	51
Finding the Volume of Figures with Hidden Cubes.....	52
Using Layers to Find the Volume of Rectangular Prisms.....	53
Using the Base of a Prism to Find Volume.....	54
Using the Dimensions of a Prism to Find Volume.....	55
Finding Missing Dimensions of Rectangular Prisms.....	56
Solving Problems with Rectangular Prisms.....	57

Topic 5: Extending Equivalence, Addition, and Subtraction to Fractions

ST Math Objectives: Common Denominators and Equivalent Fractions, Adding and Subtracting Fractions with Unlike Denominators, Patterns and Relationships

TEKS: 5.1.A 5.1.B 5.1.C 5.1.D 5.1.E 5.1.F 5.1.G 5.3.A 5.3.H 5.3.K 5.4.F 5.9.A 5.9.C

ELPS: 1.A 1.B 1.C 1.E 1.F 2.B 2.C 2.D 2.E 2.F 3.A 3.B 3.E 3.F 3.G 3.H 4.A 4.B 4.C 4.E 4.F

Adding and Subtracting Fractions with Common Denominators...	59
Adding and Subtracting Mixed Numbers with Common Denominators	60
Using Fraction Benchmarks to Estimate Sums and Differences	61
Adding and Subtracting Fractions with Related Denominators...	62
Finding a Common Denominator with Related Fractions.....	63
Adding and Subtracting Fractions and Mixed Numbers with Related Denominators	64
Choosing Strategies to Add and Subtract with Related Denominators	65
Using Dot Plots to Add and Subtract Mixed Numbers with Related Denominators	66
Finding a Common Denominator from Unrelated Denominators...	67
Adding and Subtracting Fractions with Unrelated Denominators	68
Adding and Subtracting More Than Two Fractions.....	69
Adding and Subtracting Mixed Numbers with Unrelated Denominators	70
Solving Word Problems Involving Fractions and Mixed Numbers	71

Topic 6: Extending Multiplication and Division to Fractions

ST Math Objectives: Fraction Multiplication, Introduction to Fraction Division, Common Denominators and Equivalent Fractions

TEKS: 5.1.A 5.1.B 5.1.C 5.1.D 5.1.E 5.1.F 5.1.G 5.3.A 5.3.C 5.3.H 5.3.I 5.3.J 5.3.L 5.4.B 5.4.F 5.7.A 5.9.A 5.9.C

ELPS: 1.E 2.A 2.B 2.D 2.E 2.F 3.A 3.C 3.F 3.G 3.H 4.A 4.B 4.C 4.E 4.F

Representing Non-Unit Fractions as Sums and Products of Unit Fractions	73
Using Number Lines to Model Unit Fractions Multiplied by Whole Numbers	74
Modeling and Solving Non-Unit Fractions Multiplied by Whole Numbers	75
Discovering Patterns Involving Fractions Multiplied by Whole Numbers	76
Solving Word Problems Involving Fractions Multiplied by Whole Numbers	77
Modeling and Solving Mixed Numbers Multiplied by Whole Numbers	78
Solving Word Problems Involving Mixed Numbers Multiplied by Whole Numbers	79
Modeling and Solving Multiplicative Comparison Word Problems: Mixed Unknown.....	80
Using Visual Models to Find Fractional Parts of Whole	

Numbers	81
Using Visual Models to Find Non-Unit Fractional Parts of Whole Numbers	82
Modeling and Solving Word Problems Involving Fractions	83
Exploring Division Types with Whole Numbers and Fractions	84
Dividing Unit Fractions by Whole Numbers	85
Identifying Patterns When Dividing Unit Fractions by Whole Numbers	86
Dividing Whole Numbers by Unit Fractions	87
Relating Division by Unit Fractions to Multiplication by Whole Numbers	88
Exploring Patterns When Dividing Whole Numbers by Unit Fractions	89
Solving Real-World Problems with Fraction Multiplication and Division.....	90
Solving Problems with Fractions and Four Operations	91

Topic 7: Extending Multiplication and Division to Decimals

ST Math Objectives: Multiplying with Decimals, Dividing with Decimals, Decimal Place Value

TEKS: 5.1.A 5.1.B 5.1.C 5.1.D 5.1.E 5.1.F 5.1.G 5.2.A 5.3.A 5.3.D 5.3.E 5.3.F 5.3.G 5.3.I 5.3.K 5.4.F 5.4.H 5.7.A

ELPS: 1.A 1.B 1.C 1.D 1.E 1.F 2.A 2.B 2.C 2.D 2.E 2.F 3.A 3.B 3.C 3.D 3.E 3.F 3.G 3.H 4.A 4.B 4.C 4.E 4.F

Connecting Fraction Multiplication to Decimal Multiplication	93
Discovering Place Value Patterns in Decimal Multiplication...	94
Using Factoring to Multiply Decimals.....	95
Estimating Products of Decimals and Two-Digit Whole Numbers	96
Multiplying Decimals by Two-Digit Whole Numbers to Solve Word Problems	97
Using Area Models to Multiply Tenths by Tenths	98
Exploring Strategies for Multiplying Ones and Tenths by Tenths	99
Exploring Strategies to Multiply Decimals	100
Solving Word Problems with Decimal Multiplication	101
Solving Multistep Problems with Decimal Expressions	102
Using Unit Square Models and Equivalent Fractions to Divide Whole Numbers with Decimal Quotients.....	103
Investigating Repeating Decimal Patterns	104
Using Place Value Relationships to Divide Whole Numbers with Decimal Quotients	105
Using the Standard Algorithm to Divide Whole Numbers with Decimal Quotients	106
Using Unit Square Models and Place Value Relationships to Divide Decimals by Whole Numbers.....	107
Using Decomposition Strategies to Divide Decimals by Whole Numbers	108
Using the Standard Algorithm to Divide Decimals by Whole Numbers	109
Solving Decimal Division Word Problems Using Estimation ..	110
Solving Problems with Decimal Multiplication and Division ...	111

Topic 8: Expanding Financial Literacy

ST Math Objectives: Comparing with Decimals, Multiplying with Decimals, Decimal Place Value

TEKS: 5.1.A 5.1.B 5.1.C 5.1.E 5.1.F 5.1.G 5.10.A 5.10.B 5.10.C 5.10.D 5.10.E 5.10.F 5.3.B 5.3.C 5.3.E 5.3.K

ELPS: 1.F 2.C 2.D 2.E 3.A 3.B 3.H 4.A 4.B 4.C 4.E 4.F

Solving Problems Involving Sales and Property Taxes	113
Solving Problems Involving Gross and Net Income	114
Solving Real-World Problems with Decimal Operations	115
Introducing and Balancing a Budget	116
Comparing Advantages and Disadvantages of Payment Methods	117
Solving Budget Problems When Expenses Exceed Income ..	118

Topic 9: Organizing Two-Dimensional Space

ST Math Objectives: The Coordinate Plane, Shapes and Properties, Angles

TEKS: 5.1.A 5.1.B 5.1.C 5.1.D 5.1.E 5.1.F 5.1.G 5.5.A 5.8.A 5.8.B 5.8.C 5.9.C

ELPS: 1.C 1.E 2.B 2.C 2.E 2.F 3.A 3.C 3.F 3.H 4.A 4.B 4.C 4.E 4.F

Sorting and Classifying Triangles by Side Lengths and Angles	120
Classifying Triangles into Multiple Categories and Subcategories	121
Classifying Quadrilaterals into Multiple Categories and Subcategories	122
Classifying Quadrilaterals in a Hierarchy.....	123
Evaluating Claims About Polygons	124
Exploring the First Quadrant in the Coordinate Plane	125
Representing Polygons on the Coordinate Plane.....	126
Plotting Tables of Values on the Coordinate Plane.....	127

Topic 10: Exploring Relationships in Data

ST Math Objectives: Using Data and Graphs, Patterns and Relationships, Converting Measurements

TEKS: 5.1.A 5.1.B 5.1.C 5.1.D 5.1.E 5.1.F 5.1.G 5.4.C 5.4.D 5.8.C 5.9.A 5.9.B 5.9.C

ELPS: 1.A 1.C 1.D 1.F 2.A 2.B 3.A 3.B 3.D 3.G 3.H 4.A 4.B 4.C 4.D 4.E 4.F

Exploring Variables.....	129
Graphing Additive Relationships with Input–Output Tables ..	130
Graphing Multiplicative Relationships with Input–Output Tables..	131
Identifying Independent and Dependent Variables	132
Identifying Additive and Multiplicative Relationships in Scatterplots	133
Graphing Relationships from Written Descriptions	134
Analyzing Correlations in Real-World Scatterplots.....	135
Graphing Data in Scatterplots with Broken Axes	136
Analyzing Data in Frequency Tables and Bar Graphs.....	137
Analyzing Data in Stem-and-Leaf Plots and Dot Plots	138
Analyzing Data in Multiple Representations.....	139

Topic 1

Extending Place Value, Adding, and Subtraction with Decimals

Recommended ST Math Objectives:

Decimal Place Value

Rounding Decimals

Comparing with Decimals

Name: _____

Date: _____

Extending Place Value to Thousandths

1 Represent this statement with an equation: 42 is 6 times as many as 7.

2 Round 31,692 to the nearest thousand.

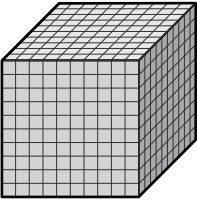
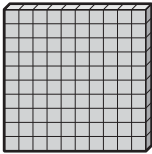
3 If  represents 1.0, what does  represent?

Ones	●	Tenths	Hundredths	Thousandths

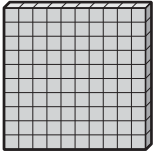
4 If  represents 0.01, what does  represent?

Ones	●	Tenths	Hundredths	Thousandths

5 The harvest at a banana farm was 146,876 bananas. The next year, the same farm harvested 278,382 bananas. How many bananas did they harvest in the 2 years put together?

Name: _____

Date: _____

Representing Decimals in Multiple Forms

- ① Solve.

$$3,025 - 486 = \boxed{}$$

- ② Draw a set of parallel lines.

- ③ How is this decimal written as a fraction?

$$0.2 = \frac{\boxed{}}{\boxed{}}$$

- ④ How would you write this number as a decimal?

$$(2 \times 1) + (5 \times \frac{1}{10}) + (7 \times \frac{1}{100}) = \boxed{}$$

- ⑤ Last year, a bookstore sold 146,876 books. This year, it sold 278,382 books. How many more books did the bookstore sell this year than last year?

Name: _____

Date: _____

Investigating Multiplicative Comparisons with Different Unit Wholes

1 Write 45,903 in expanded notation.

2 Match each angle to the correct description.

right angle

obtuse angle

acute angle

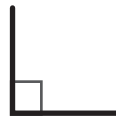

3 Write 3.14 in expanded notation.

$$\left(\square \times \square \right) + \left(\square \times \square \right) + \left(\square \times \square \right)$$

4 Write 25.62 in expanded notation.

$$\left(\square \times \square \right) + \left(\square \times \square \right) + \left(\square \times \square \right) + \left(\square \times \square \right)$$

5 A school cafeteria ordered 42 boxes of ketchup packets with 86 packets in each box. **Estimate** about how many packets of ketchup they ordered. Explain your thinking.

Did you explain your thinking?



Name: _____

Date: _____

Composing and Decomposing Decimals Using Place Value

- 1 Decompose the fraction $\frac{4}{6}$ into a sum of fractions.

- 2 Draw all of the lines of symmetry.



- 3 Circle the group of tokens that represents 2.3.



Explain your thinking.

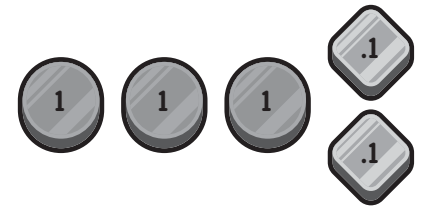
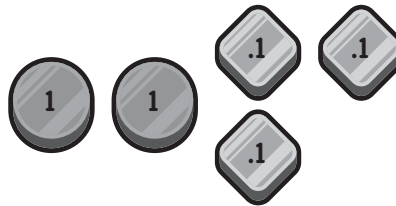

- 4 Write 0.375 in expanded notation.

$$(\square \times \square) + (\square \times \square) + (\square \times \square)$$

- 5 There are 16 buses that pick up students from a school. If each bus can seat 70 students, how many total students can ride a bus home from school?

Name: _____

Date: _____

Comparing Decimals with Number Lines

$$930 - 287 = \boxed{}$$

$$468 + 392 = \boxed{}$$

- 2) A tablecloth is 8 feet long. A table is 86 inches long. How much longer is the tablecloth than the table? Show your work.

Did you show your work?

- 3) a) Plot the following points on the number line: 0.037, 0.073, 0.03.

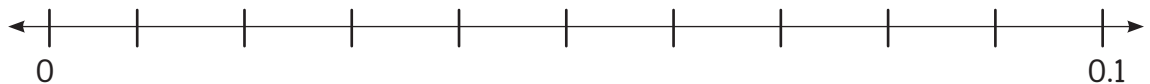

- b) Complete the inequality with these numbers: 0.037, 0.073, 0.03.

$$\boxed{} < \boxed{} < \boxed{}$$

- 4) a) Complete the inequality with these numbers: 0.8, 0.008, 0.08.

$$\boxed{} > \boxed{} > \boxed{}$$

- b) Complete the sentences:

0.08 is 10 times as much as .

0.08 is one tenth as much as .

Name: _____

Date: _____



Comparing and Ordering Decimals to the Thousandths Place

- 1 Compare using $>$, $<$, or $=$.

$$58.78 \bigcirc 58.86$$

- 2 Mateo bought 400 cm of fabric. How many meters of fabric did Mateo buy?

- 3 Fill in the missing box with a number that fits in the order from least to greatest.

2.1	2.31		2.4	2.7
least				greatest

- 4 Create a true comparison statement using numbers of your choice.

$$\boxed{\text{.}} < \boxed{\text{.}}$$

- 5 Mateo made a snack as a surprise for his teacher. The recipe called for $\frac{2}{8}$ cup almonds and $\frac{4}{8}$ cup raisins. How many cups of almonds and raisins did he need to make the snack?

Name: _____

Date: _____

Rounding Decimals Through the Thousandths

- ① A rectangular carpet has an area of 96 square feet. If the length of the carpet is 12 feet, what is the width? Explain your thinking.

- ② Draw a set of perpendicular lines.

③ a) 
rounds to 3.0.

b) 
rounds to 4.0.

- ④
- I am thinking of a number that has the digits 1, 2, 3, and 4.
 - The number is greater than 3 but less than 4.
 - The number has a 1 in the thousandths place.

What might the number be?



- ⑤ If it takes a person 2,252 steps to walk 1 mile, how many steps would it take that person to walk 5 miles?

Name: _____

Date: _____

Adding and Subtracting Decimals with Place Value Strategies

- 1 Complete the equations.

$9 \times 8 = \boxed{}$

$9 \times 80 = \boxed{}$

$9 \times 800 = \boxed{}$

$3 \times 7 = \boxed{}$

$3 \times 70 = \boxed{}$

$30 \times 70 = \boxed{}$

- 2 A rectangle has a length of 8 inches and a width of 4 inches. What is its area?
Show your work.

Did you show your work?

- 3 Find the sum.

$$57.208 + 6.87$$

Estimate and then solve.

My estimate:



=

Tens	Ones	.	Tenths	Hundredths	Thousandths
		.			
		.			
		.			

- 4 Find the difference.

$$43.921 - 28.35$$

Estimate and then solve.

My estimate:



=

Tens	Ones	.	Tenths	Hundredths	Thousandths
		.			
		.			
		.			

Name: _____

Date: _____

Solving Word Problems Involving Decimal Addition and Subtraction

- ① Round 872,611 to the nearest thousand.
- ② At the art store, a sketch pad costs \$17.19 and a set of pencils costs \$5.73.

a) Estimate the cost of both items.

b) Determine the exact cost of both items.

③ $23.09 + 5.93 =$

④ $7.24 - 3.06 =$

- ⑤ A school wanted to get enough sidewalk chalk for each student in 5th grade to have a stick of chalk. There are 104 students in 5th grade. The package they bought has 12 boxes with 16 sticks of chalk in each box. Will there be enough chalk for each student to have their own stick? Explain your thinking.

Did you explain your thinking?



Name: _____

Date: _____



Anjali

Discovering Patterns in Repeated Multiplication and Division by 10

- 1 Solve.

$$\frac{3}{5} + \frac{2}{5} = \boxed{}$$

- 2 Find the value of the missing angle.

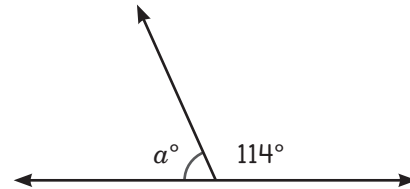

- 3 Which is more money, \$100 or 10,000 dimes? Explain your thinking.

Did you explain your thinking?

- 4 Finish the equation.

$$4.36 \times \boxed{} = 4,360$$

- 5 Anjali wanted to find out how far she traveled from her house to the coffee shop. Using the picture, what was the total distance Anjali traveled?

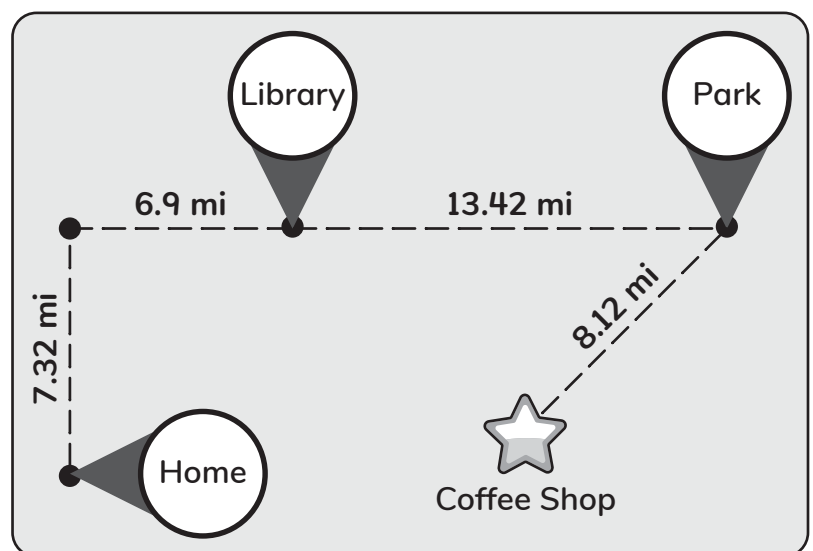

Name: _____

Date: _____



Exploring Multiplicative Comparisons with Powers of Ten

- ① Solve.

$$3\frac{3}{8} + 5\frac{5}{8} = \boxed{}$$

- ② Mateo is painting tiles for an art project. He painted 194 tiles last month and 178 tiles this month. If he wants to paint a total of 400 tiles, how many more tiles does he need to paint? Show your thinking.

③ a) $10 \times 10 \times 10 = \boxed{}$

b) $10 \times 10 \times 10 \times 10 = \boxed{}$

- ④ Fill in the blanks to make the equation and statements true.

a) $\boxed{} \times 10 = 65$

b) 65 is 10 times as much as $\boxed{}$.

c) $\boxed{}$ is $\boxed{}$ as much as 65.

- ⑤ Mateo wants to buy 4 pencils that each cost \$0.75. What is the total cost of the pencils? Show your thinking.

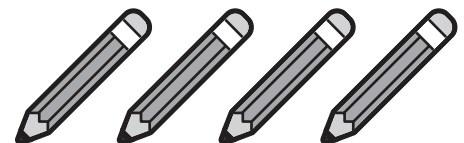

Did you show your thinking?



Name: _____

Date: _____



Converting Between Units of Metric Length

- 1 If a circle is divided into 4 equal parts, what is the measurement of each angle that is formed?

- 2 A scientist measured the length in inches of the bugs he collected at the pond. Create a dot plot to show the following data: $\frac{2}{8}$, $\frac{1}{8}$, $\frac{2}{8}$, $\frac{3}{8}$, $\frac{3}{8}$, $\frac{1}{8}$, $\frac{2}{8}$, $\frac{2}{8}$, $\frac{3}{8}$.

- 3 a) 1 meter = centimeters
b) centimeters = 100 millimeters

- 4 50,000 centimeters \div = meters

- 5 Mateo went on a 1.6-kilometer walk with his dog, Arturito. How many meters did they walk?

Name: _____

Date: _____



Brian

Solving Word Problems Involving Metric Measurements

- 1 Brian is making chili for the campground dinner. If he uses $3\frac{3}{4}$ cups of pinto beans, $1\frac{1}{4}$ cups of white beans, and $2\frac{1}{4}$ cups of kidney beans, how many cups of beans will Brian use in his chili? Explain your thinking.

Did you explain your thinking?



- 2 What is the value of the 6 in the number 3,654? How does that compare to the value of the 6 in the number 6,523? Explain your thinking.

Did you explain your thinking?



3 $27.19 + 12.81 =$

4 $11.43 - 8.56 =$

- 5 A dog is fed 60 grams of food twice a day. How many **kilograms** of food does the dog eat in a day?

Topic 2

Extending Multiplication and Division to Multidigit Whole Numbers

Recommended ST Math Objectives:

Multiplication Algorithm

Whole Number Division

Prime and Composite Numbers

Name: _____

Date: _____

Exploring Zero Patterns with Multiples of 10

① Round 48.347 to the nearest hundredth.

② Use $>$, $<$, or $=$ to compare the fractions.

$$\frac{7}{8} \quad \bigcirc \quad \frac{3}{2}$$

③ $2 \times 3 =$

$20 \times 3 =$

$20 \times 30 =$

④ If $9 \times 52 = 468$, then $90 \times 52 =$.

$\times 520 = 4,680$

\times $= 468,000$

⑤ There are 5,280 feet in 1 mile. How many feet are in 4 miles?
Show your thinking with an equation.

Did you show your thinking
with an equation?



Name: _____

Date: _____

Using Place Value to Multiply Multidigit Numbers by Two-Digit Numbers

- 1 Draw any possible lines of symmetry.

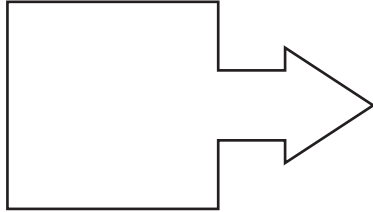

- 2 A recipe for punch calls for 2 liters of lemonade and 3 liters of mango juice. How many milliliters of punch does the recipe make? Explain your thinking.

Did you explain your thinking?



- 3 Use partial products to solve.

$$\begin{array}{r} 364 \\ \times 27 \\ \hline \end{array}$$

<input type="text"/>	← 300×20
<input type="text"/>	← 300×7
<input type="text"/>	← 60×20
<input type="text"/>	← 60×7
<input type="text"/>	← 4×20
+ <input type="text"/>	← 4×7

- 4 Would you use 60×20 or 60×30 to estimate the product of 64×27 ? Explain your thinking.

Did you explain your thinking?



Name: _____

Date: _____

Multiplying with the Standard Algorithm

- ① Ms. Sanchez's class has 12 points in the school-wide read-a-thon. Mr. Banh's class has 4 times as many points as Ms. Sanchez's class. How many points does Mr. Bahn's class have?
- ② How many times greater is the 4 in 147,210 than the 4 in 204,988? Explain your thinking.

- ③ Estimate. 293×6 is about \times = .
- Multiply with each strategy.

Partial Products	Standard Algorithm
$\begin{array}{r} 293 \\ \times \quad 6 \\ \hline \end{array}$ <div style="text-align: right; margin-top: 10px;"> $\leftarrow 6 \times$ \leftarrow \leftarrow </div>	$\begin{array}{r} 293 \\ \times \quad 6 \\ \hline \end{array}$

- ③ Estimate. 64×87 is about \times = .
- Multiply with each strategy.

Partial Products	Standard Algorithm
$\begin{array}{r} 64 \\ \times \quad 87 \\ \hline \end{array}$ <div style="text-align: right; margin-top: 10px;"> \leftarrow \leftarrow \leftarrow \leftarrow </div>	$\begin{array}{r} 64 \\ \times \quad 87 \\ \hline \end{array}$

Name: _____

Date: _____

Solving Open-Ended Problems with the Standard Algorithm

1 Draw an example of a ray and a line segment.

2 Round 84.788 to the nearest tenth.

3 At the amusement park, the Starship ride can run with 18 to 35 riders. It runs between 85 and 107 times per day.

a) What is the **greatest** number of riders in one day?

Estimate:

$$\boxed{} \times \boxed{} = \boxed{}$$

Exact:

b) What is the **least** number of riders in one day?

Estimate:

$$\boxed{} \times \boxed{} = \boxed{}$$

Exact:

c) What is another reasonable number of riders in one day? Explain your thinking.

Did you show
your work?



Name: _____

Date: _____



Introducing Fractions as Division

① Brian rode his bike for 6 kilometers on Saturday. How many meters did Brian ride?

② The fraction $\frac{5}{6}$ can be decomposed into $\frac{1}{6} + \frac{1}{6} + \frac{1}{6} + \frac{1}{6} + \frac{1}{6}$.
What is another way to decompose the fraction $\frac{5}{6}$?

③ Which expression will have a greater quotient? Explain your thinking.

$$3 \div 8 \quad \text{or} \quad 8 \div 3$$

④ Brian had 7 cookies to share with 10 of his friends. Will each friend get a whole cookie? Explain your thinking.

Did you explain your thinking?

⑤ Brian learned how to bake blueberry muffins. He wanted to take some of his muffins to school. He brought 2 blueberry muffins and wanted to share them with his 3 friends. Can you determine how to share the muffins fairly among his 3 friends? Write an expression or equation to represent your thinking.

Did you write an expression or equation to explain your thinking?

Name: _____

Date: _____

Exploring Division with Mixed Number Quotients

- ① Circle the shapes that have 2 sets of parallel sides.

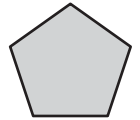
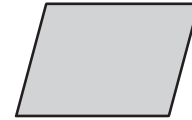
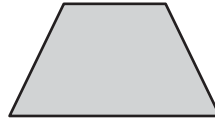
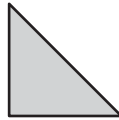

② Solve. $34 \times 57 =$

- ③ Solve. Write the quotient as a mixed number.

$$9 \div 4 = \square$$

$$14 \div 4 = \square$$

- ④ 8 critters decided to share 17 treats. If they wanted to share them fairly, how many treats would each critter get? Include an expression or an equation to show your thinking.

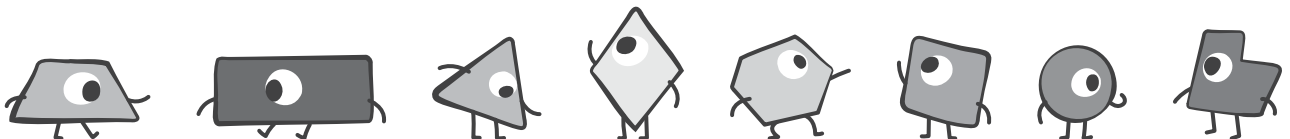

Did you write an expression or equation to explain your thinking?



Name: _____

Date: _____



Interpreting Remainders in Context

- 1 Circle ALL of the triangles that appear to be right triangles.

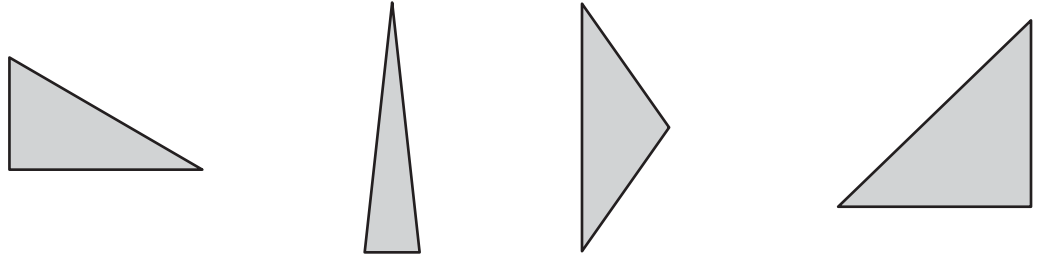

- 2 A number is shown in expanded notation.
 $(5 \times 100) + (3 \times 10) + (2 \times 1) + (8 \times 0.01) + (9 \times 0.001)$
Write this number in standard form.

- 3 Donner is planning another camping trip. The tents they use will sleep 4 people. If there are 10 people going on the trip, how many tents will be needed?

- 4 Solve.

$$8 \div 3 = \boxed{}$$

- 5 More s'mores supplies were found in a camper's tent. They now have 45 graham crackers, 24 marshmallows, and 15 chocolate bars. How many s'mores can they now make?

S'more Recipe (makes 1)

2 graham crackers

1 marshmallow

$\frac{1}{2}$ chocolate bar

Put chocolate on one of the crackers. Then roast a marshmallow and put it between the chocolate and the other cracker.

Name: _____

Date: _____

Exploring Division Strategies with One-Digit Divisors

- 1 If the area of this rectangle is 32 square centimeters, what is the value of l ?

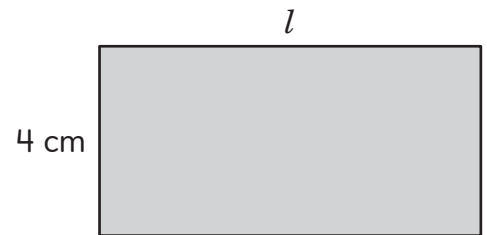

- 2 Write 38.799 in expanded notation.

- 3 The quotient of $537 \div 9$ is  Select 1.

between 10 and 40.

between 40 and 80.

between 80 and 120.

greater than 120.

- 4 Solve.

$$537 \div 9 = \boxed{}$$

- 5 There is a collection of 426 acorns that 3 squirrels want to share equally. How many acorns would each squirrel get? Show your thinking with an equation.

Did you show your thinking with an equation?



Name: _____

Date: _____

Using Place Value Strategies to Divide by Multiples of 10

- ① A student ran 3 miles to raise money for her school. A teacher ran 3 times as many miles as the student. How many miles did the teacher run?

- ② Use the standard algorithm to solve.

$$\begin{array}{r} 364 \\ \times 27 \\ \hline \end{array}$$

- ③ a) Circle the expression that has the greater quotient.

$$3,200 \div 8$$

$$3,200 \div 80$$

- b) Explain your reasoning.

- ④ Find the value of x in this area model.

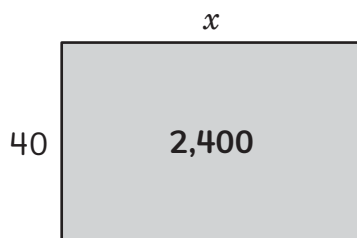

- ⑤ On a farm, the workers are packing 3,600 pears into boxes that can each hold 40 pears. How many boxes can they fill? Explain your thinking.

Did you explain your reasoning?



Did you explain your thinking?



Name: _____

Date: _____

Dividing by Two-Digit Divisors

- ① Use the standard algorithm to solve.

$$\begin{array}{r} 82 \\ \times 83 \\ \hline \end{array}$$

- ② Use $>$ or $<$ to compare.

$$0.624 \bigcirc 0.642$$

- ③ a) Estimate:

$6,852 \div 12$ is about

$$\boxed{} \div \boxed{} = \boxed{}$$

- b) Solve with the standard algorithm.

$$12 \overline{) 6,852}$$

- ④ a) Estimate:

$4,592 \div 25$ is about

$$\boxed{} \div \boxed{} = \boxed{}$$

- b) Solve with the standard algorithm.

$$25 \overline{) 4,592}$$

- ⑤ There are 5,280 feet in one mile. How many feet are in 4 miles? Show your work.

Did you show your work?



Name: _____

Date: _____



Solving Division Word Problems with Remainders

1 Solve. $38.4 - 29.03 =$

2 Write twenty-five and four hundredths in standard form.

3 Dani and Mateo are building more doghouses. Each doghouse needs 40 shingles and 60 nails. If 1,280 shingles and 1,800 nails have been donated, how many doghouses can Dani and Mateo build? Explain your thinking.

4 Dani spent 120 minutes a day for 14 days working on her doghouse project. How many **hours** did Dani spend working on doghouses?

Name: _____

Date: _____

Using Multiples of Two-Digit Divisors to Divide

- ① Compare using $>$, $<$, or $=$.

$$35.808 \bigcirc 35.088$$

- ② This large square represents 1 whole. Show 0.38.

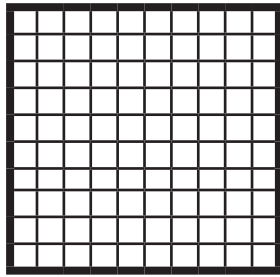

- ③ a) Complete the list of multiples.

$$10 \times 17 = \boxed{}$$

$$20 \times 17 = \boxed{}$$

$$40 \times 17 = \boxed{}$$

$$80 \times 17 = \boxed{}$$

- b) Use the list of multiples to help you find the quotient of $1,411 \div 17$.

- ④ How does using a list of multiples help you divide larger numbers?

Name: _____

Date: _____



Solving Problems Involving Customary Unit Conversions

① Use the standard algorithm to solve.

$$\begin{array}{r} 265 \\ \times 32 \\ \hline \end{array}$$

② Use $>$ or $<$ to compare.

$$2.818 \bigcirc 2.881$$

③ Use the conversion chart to help you solve.

Brian made 2 gallons of lemonade for the birthday party.

a) How many pints of lemonade did Brian make?

b) How many cups of lemonade did Brian make?

Customary Units

1 gallon = 4 quarts

1 quart = 2 pints

1 pint = 2 cups

1 cup = 8 fluid ounces

④ There are 5,280 feet in 1 mile. How many feet are in 6 miles?

Topic 3

Exploring Multistep Problems

Recommended ST Math Objectives:

Interpret Expressions
Patterns and Relationships
Converting Measurements

Name: _____

Date: _____



Relating Models and Expressions with Parentheses

- Write 238.224 in expanded notation.
- 0.5 liters of party punch were left over after the school picnic. How many milliliters of party punch were left over?
- Circle the expression that has the least value.
 $6 \times (2 + 3) + 4$ $(6 \times 2) + 3 + 4$ $6 \times (2 + 3 + 4)$
- Circle the expression that has the greatest value.
 $(17 + 23) + 50$ $17 + 23$ $50 \times (17 + 23)$
- Anjali is reading a 308-page book. She reads 14 pages every day. How many days will it take Anjali to read the entire book?

Name: _____

Date: _____

Representing Multistep Equations with Parentheses

- ① Solve.

$$(6 \times 5) + 2 = \boxed{}$$

- ② Use $>$, $<$, or $=$ to make this statement true.

$$121.384 \bigcirc 121.348$$

- ③ Use parentheses to create an expression that matches this model.

$$3 + 3 \times 5 + 1$$

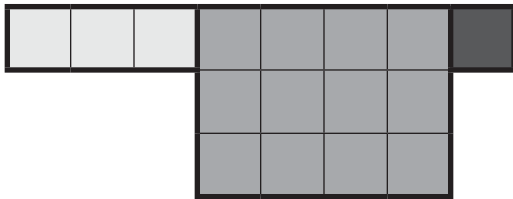

- ④ Use the grid to represent the expression $3 + (4 \times 2)$.

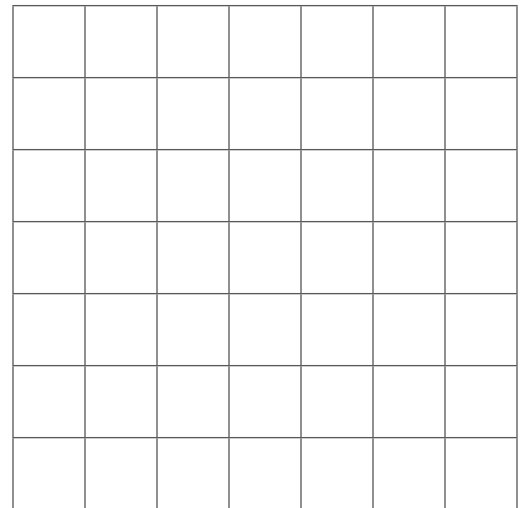

- ⑤ The pattern for making a blanket needs 225 yards of yarn. If each roll of yarn has 32 yards, how many rolls of yarn should be bought to make the whole blanket? Show your thinking.

Did you show your thinking?



Name: _____

Date: _____

Relating Expressions, Models, and Words

① Solve. $72 \times 35 =$

- ② a) Using the grid, create a model to represent "2 times the sum of 3 and 4."
b) Write an expression to represent your model.

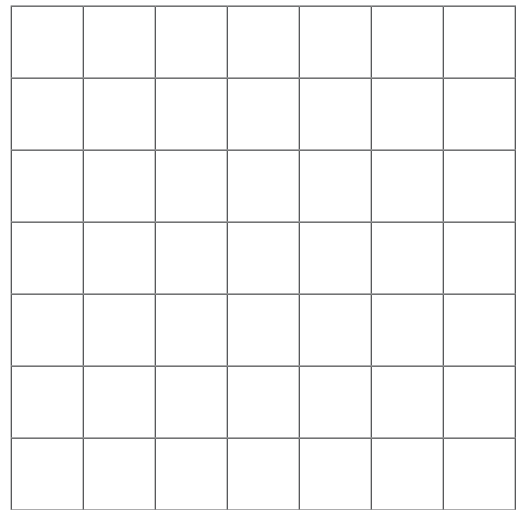

- ③ Write an expression to represent "triple the sum of 8 and 2 and subtract 5."

- ④ What is the product of 156 and 22 added to 30?

Name: _____

Date: _____



Using Order of Operations to Simplify Expressions

- ① Use the standard algorithm to solve.

$$24 \overline{) 2,136}$$

- ② Solve.

$$92.17 - 38.20 = \boxed{}$$

- ③ Use order of operations to simplify each expression.

$$6 + 2 \times 8 - 3$$

$$14 - 9 \div 3 \times 2$$

$$5 \times 8 + 7 \times 4$$

- ④ Mateo and Dani are finding the sum of $9 + 4 + 1$.

Mateo says, "Order of operations says that we should solve addition from left to right. So we have to add $9 + 4$ before we add 1."

Dani says, "When we are only adding or only multiplying, we can be more efficient by using a different order."

Who is correct? Explain your thinking.

Name: _____

Date: _____

Simplifying with Nested Parentheses

- ① Circle the expression that has the greater quotient.

$$4,800 \div 8$$

$$4,800 \div 80$$

- ② Round 74.984 to the nearest tenth.

- ③ Use order of operations to simplify the expression.

$$270 \div 3 + 4[2 \times 5 + (8 - 6)]$$

- ④ A farmer is selling 5 fruit baskets. Each basket contains 4 peaches, 6 plums, and 2 cartons of 10 figs. This equation shows the total pieces of fruit in the baskets: $f = 5[4 + 6 + 2(10)]$.

a) What does each of these numbers and symbols mean in the equation?

f :

5:

4:

6:

2:

10:

b) Solve the equation. How many pieces of fruit are there?

$$f = 5[4 + 6 + 2(10)]$$

Name: _____

Date: _____

Solving Multistep Area Problems

- 1 Circle the shapes that appear to have perpendicular lines.

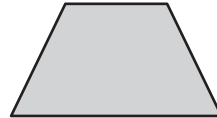
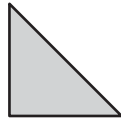

- 2 Circle the numbers that are multiples of 12.

36

72

88

24

46

- 3 Use the model to answer the following questions.

a) What is the area of the pool in sq. ft?

b) What is the area of the concrete walkway in sq. ft?

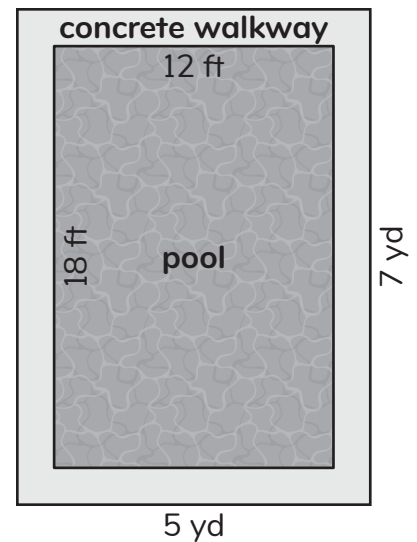

- 4 It rained on the day of the carnival, and only 350 adults and 800 children attended. How much money did the carnival make?

Admission Ticket Prices

Adult (18 years and up)	\$5
Child (Age 2–17)	\$3

Name: _____

Date: _____

Solving Multistep Problems with All Four Operations

- ① Use $>$ or $<$ to compare.

$$4.229 \bigcirc 4.922$$

- ② Solve.

$$2,086 \div 35 = \boxed{}$$

- ③ There are 15 packs of unsharpened pencils on the teacher's desk. Each pack has 12 pencils. There are also 25 sharpened pencils on the teacher's desk. How many pencils are on the teacher's desk in all? Show your work with an equation.

Did you show your thinking with an equation?



- ④ At the Fall Fest Fundraiser, the school sold 62 fruit baskets.

a) Find the cost of 1 fruit basket.

Fruit Baskets Sold	Money Raised
62	\$1,488

- b) After the sale, they had 8 fruit baskets left, so they sold them at half the price to the volunteers. What was the total amount that the school made selling half-price and full-price fruit baskets? Show your work.

Did you show your work?



Name: _____

Date: _____



Representing Multistep Situations with Strip Diagrams and Equations

- 1 Circle the shapes that appear to have at least one set of perpendicular lines.

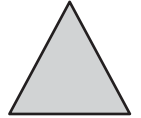
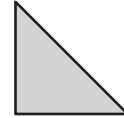

- 2 Represent the statement “42 is 7 times as many as 6” as an equation.

- 3 Mateo bought a shirt for \$18, 3 bracelets for \$4 each, and a hat for h dollars. He spent a total of \$46.

- a) Draw a strip diagram to represent the situation.

- b) What was the cost of the hat?

- c) Circle the equation that represents the model.

$$18 + (3 \times 4) + h = 46$$

$$18 + 3(4) - h = 46$$

- d) Plug your answer into the equation and simplify to check that the equation is correct.

Name: _____

Date: _____



Choosing Operations to Represent Situations with Equations

1 Write an expression to represent "the quotient of 72 divided by 8 subtracted from 12."

2 Write twenty-five and four hundredths in standard form.

3 Fill in the operations (+, −, ×, or ÷) to complete the equation to represent each situation.

a) Dani plans to use 14 wooden boards to make bird houses. She chooses 4 packages that each contain s short boards as well as 2 long boards.

$$14 = 4 \bigcirc s \bigcirc 2$$

b) Dani also buys 75 steel nails and 3 packages that each contain z zinc-coated nails. She buys a total of 150 nails.

$$75 \bigcirc 3 \bigcirc z = 150$$

4 Dani had a board that was 108 inches long. She cut a piece that was 12 inches long and 4 pieces that were each 18 inches long. She wants to know how many inches of wood, w , she has left. Complete the strip diagram to model her situation.

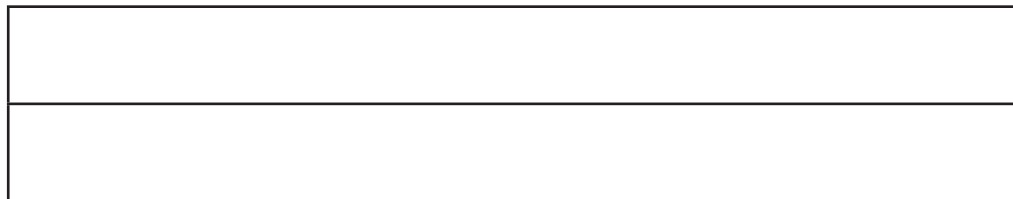

Circle the equation that matches Dani's situation:

$$108 = 12 - (18 \times 4) - w$$

$$108 = 12 + (18 \times 4) - w$$

$$108 = 12 + (18 \times 4) + w$$

Topic 4

Exploring Two- and Three-Dimensional Space

Recommended ST Math Objectives:

Volume

Shapes and Properties

Prime and Composite Numbers

Name: _____

Date: _____

Finding the Area and Perimeter of Rectangles and Squares

- 1 Write 20,428 in expanded notation.

In the number 20,428, the 2 in the ten thousands place is times the value of the 2 in the tens place.

- 2 a) Draw an obtuse angle. b) Draw an acute angle.

- 3 a) One formula for the perimeter of a rectangle is shown. Use multiplication to write the formula a different way.

$$P = l + l + w + w$$

$$P = \text{$$

- b) Write the formulas for the area and perimeter of a square with a side length of s .

$$A = \text{$$

$$P = \text{$$

- 4 A square floor tile has an area of 81 inches. What is the length of each side? What is the perimeter? Remember to include units.

side length =

perimeter =

- 5 The rectangular window inside a door has a length of 14 inches and a perimeter of 48 inches. What is the width of the window? What is its area? Remember to include units.

width =

area =

Name: _____

Date: _____

Determining Prime and Composite Numbers

- ① Use the standard algorithm to solve.

$$12 \overline{) 8,268}$$

- ② Use the standard algorithm to solve.

$$\begin{array}{r} 485 \\ \times 32 \\ \hline \end{array}$$

- ③ Is 37 prime or composite? Explain your thinking.

Did you explain your thinking?

- ④ List the factor pairs for 12.

- ⑤ List all the prime numbers between 10 and 30. Explain your thinking.

Did you explain your thinking?

Name: _____

Date: _____



Brian

Using Multiples to Generate Prime Numbers

① Use the standard algorithm to solve.

$$\begin{array}{r} 382 \\ \times 39 \\ \hline \end{array}$$

② Use the standard algorithm to solve.

$$8 \overline{) 4,920}$$

③ a) Is 35 an odd number? **Yes No** b) Is 35 a prime number? **Yes No**



Explain your thinking.

④ List the factor pairs for 45.

⑤ Brian says the number 2 is composite because it is even. Do you agree with Brian? Explain your thinking.

Did you explain your thinking?



Name: _____

Date: _____

Solving Multistep Problems with Area and Perimeter

1 Solve. $2,428 \times 8 =$

2 A number is greater than 0.7 and less than 0.8. List 3 numbers that fit this description.

3 This polygon has a perimeter of 21 centimeters. What is the length of side x ?

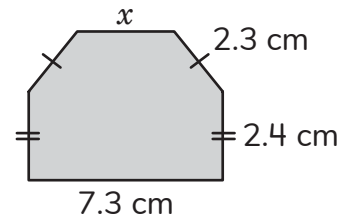

4 The perimeter of a rectangular field is 36 meters. The width of the field is 7 meters. What is the length of the field? What is the area of the field? Show your work. Remember to include units.

Did you show your work?



5 A lunch box has a square main dish section with an area of 36 square inches and a square side dish section with an area of 16 square inches. What is the area of the dessert section? Show your work.

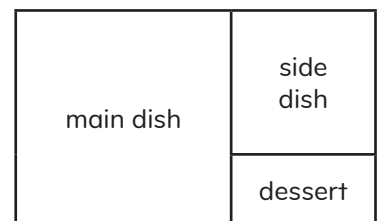

Name: _____

Date: _____

Exploring Volume of Solid Figures

- 1 List the factor pairs for 80.

- 2 Solve.

$$9 \times 3 \times 7 = \boxed{}$$

- 3 How many unit cubes would be needed to build this figure?

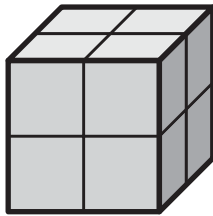

cubic units

- 4 How many unit cubes would be needed to build this figure?

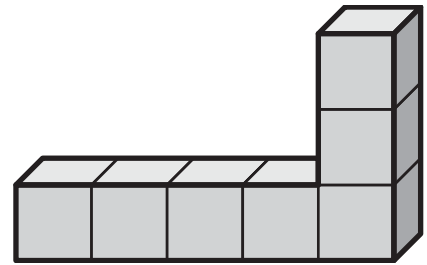

cubic units

- 5 How does using unit cubes help when you are finding the volume of a figure?

Name: _____

Date: _____

Exploring Volume of Containers and Solid Figures

- ① Will $9 \div 4$ or $4 \div 9$ have a greater quotient? Explain.

- ② Find the area of the rectangle.



- ③ How many unit cubes would be needed to build this figure?

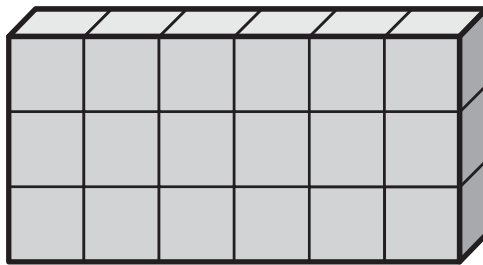

cubic units

- ④ The bottom layer of a box is packed tightly with 12 unit cubes. The box can hold 4 layers of cubes. How many unit cubes will be needed to fill the box?

Name: _____

Date: _____

Finding the Volume of Figures with Hidden Cubes

- ① List all of the prime numbers between 2 and 30.
- ② Will $\frac{1}{8} + \frac{4}{8} + \frac{2}{8}$ be more or less than 1? How do you know?

- ③ Draw a figure with a volume of 8 cubic units.

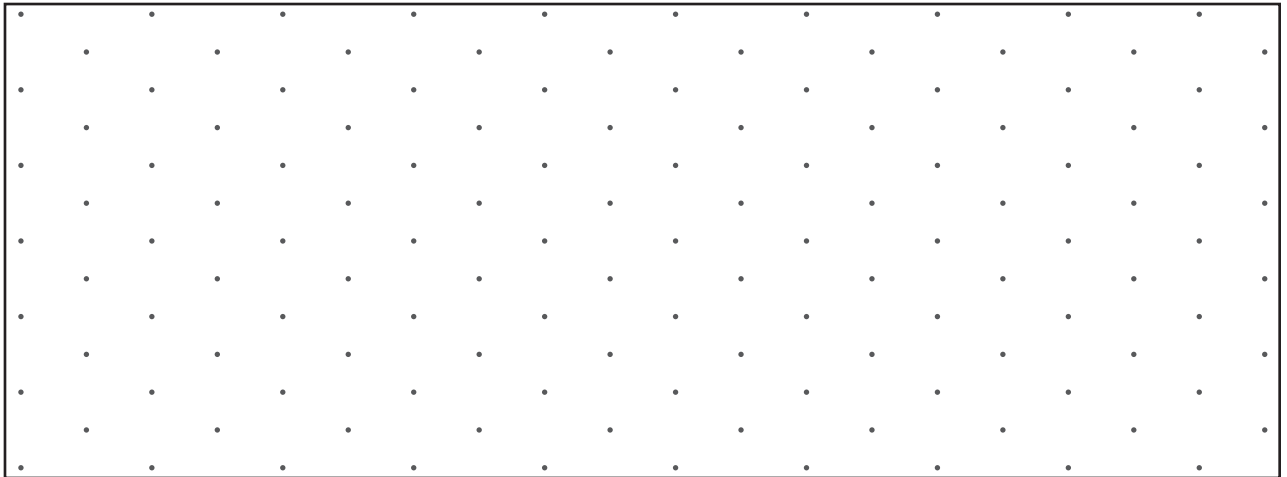

- ④ If there are 9 unit cubes in the bottom layer of a rectangular prism and there are 2 layers, how many unit cubes will be needed to build the figure?
- ⑤ How many layers of this shape would be needed to make a figure with a volume of 45 cubic units?

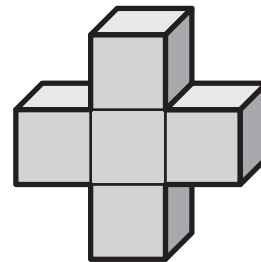

layers

Name: _____

Date: _____

Using Layers to Find the Volume of Rectangular Prisms

① Use the standard algorithm to solve.

$$28 \overline{) 6,860}$$

② Use the standard algorithm to solve.

$$\begin{array}{r} 502 \\ \times 88 \\ \hline \end{array}$$

③ a) A rectangular prism has a layer of 18 unit cubes. There are 5 layers of unit cubes. Write an equation to find the number of unit cubes in the rectangular prism.

$$\boxed{} \times \boxed{} = \boxed{} \text{ cubic units}$$

b) Circle the expressions that might represent the volume of the rectangular prism.

$$(6 \times 3) \times 5 \quad (6 + 3) + 5 \quad (2 \times 9) \times 5 \quad (4 \times 4) \times 5$$

④ Anjali says that she can use the expression $(4 \times 4) \times 5$ or $(4 \times 5) \times 4$ to find the volume of this rectangular prism. Do you agree with Anjali? Explain your thinking.

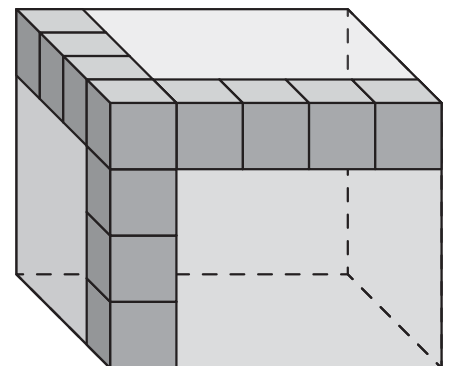

Did you explain your thinking?



Name: _____

Date: _____

Using the Base of a Prism to Find Volume

- ① Circle the numbers that are prime. **11 12 7 14 9 5 15 2 17**
- ② A fruit punch recipe uses 2 liters of orange juice, 250 mL of pineapple juice, 250 mL of cranberry juice, and 500 mL of seltzer. What is the total volume of punch that the recipe makes? Include units in your answer.

- ③ a) What is the area of the base of the rectangular prism?

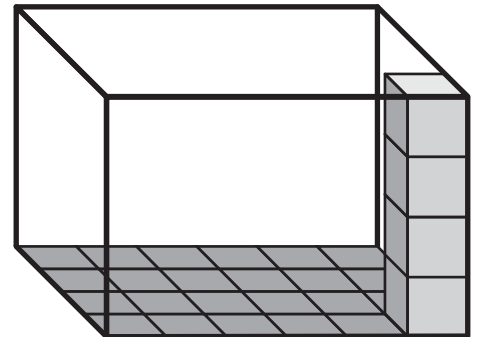

- b) What is the volume of the rectangular prism?
Show your work.

Let's call this face the **base** of this rectangular prism.

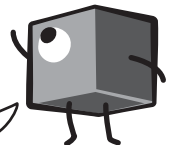

- ④ A rectangular prism has a volume of 60 cubic inches and a height of 5 inches.
Circle any dimensions that could be used for the base.

2 inches × 6 inches

3 inches × 3 inches

2 inches × 5 inches

3 inches × 4 inches

Name: _____

Date: _____



Anjali

Using the Dimensions of a Prism to Find Volume

- ① Solve.

$$4\frac{3}{8} - 2\frac{1}{8} = \boxed{}$$

- ② How would you write this number in standard form?

$$(7 \times 1) + (3 \times \frac{1}{10}) + (5 \times \frac{1}{100})$$

- ③ Find the volume of the rectangular prism.

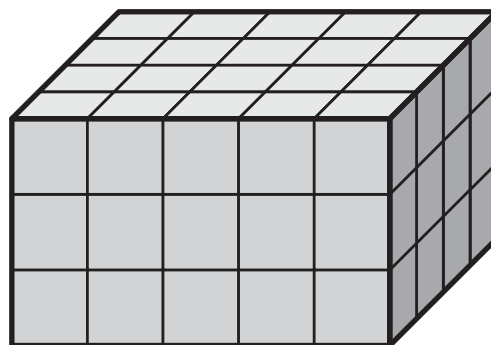

- ④ Complete the equation to find the volume of the rectangular prism.

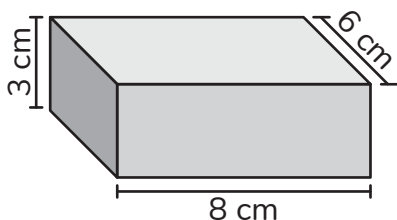

$$V = \boxed{} \times \boxed{} \times \boxed{}$$

$$V = \boxed{}$$

- ⑤ Anjali is planning to build a toy box for her toys. She calculated that she needs at least 75 cubic feet to store all of her toys. Will this box have enough space? Show your thinking.

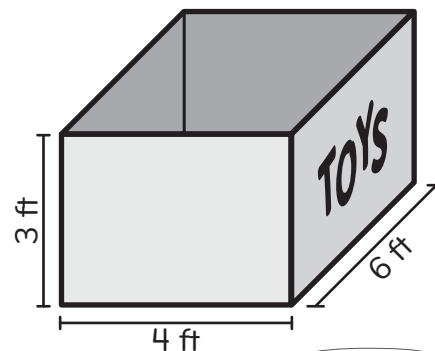

Did you show your thinking?



Name: _____

Date: _____



Finding Missing Dimensions of Rectangular Prisms

- 1 Find the volume of a rectangular prism that has a length of 12 inches, a width of 4 inches, and a height of 8 inches.
- 2 Write the factor pairs for 64.
- 3 What is the volume of a rectangular prism with a base of 27 square inches and a height of 5 inches?
- 4 If a rectangular prism has a volume of 24 cubic inches and a height of 2 inches, what might be the length and width?
- 5 Anjali wants to buy a series of historical books that each cost \$13. There are 12 books in the series. Her aunt gives her \$75 to spend on books and she already has \$48 saved. How much more money would she need to save to buy the whole set?
Show your thinking.

Did you show
your thinking?



Name: _____

Date: _____

Solving Problems with Rectangular Prisms

- ① Use the standard algorithm to solve.

$$34 \overline{) 3,910}$$

- ② Use the standard algorithm to solve.

$$\begin{array}{r} 434 \\ \times 62 \\ \hline \end{array}$$

- ③ A small fish tank has a volume of 12 cubic feet. If the length is 3 feet and the width is 2 feet, what is the height of the fish tank?

- ④ What could be the dimensions of a fish tank that has a volume of 24 cubic feet?

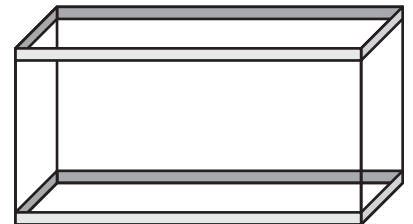

- ⑤ What is important to remember when finding volume?

Topic 5

Extending Equivalence, Addition, and Subtraction to Fractions

Recommended ST Math Objectives:

Common Denominators and Equivalent Fractions

Adding and Subtracting Fractions with Unlike Denominators

Patterns and Relationships

Name: _____

Date: _____



Anjali

Donner

Adding and Subtracting Fractions with Common Denominators

- 1 Anjali added 6 and 9 and then multiplied the sum by 4. What number did she find?



Write an equation to show Anjali's work.

- 2 Solve.

$$5 \times (9 + 2) = \boxed{}$$

- 3 What are 2 ways that you could add these parts to create $\frac{7}{3}$?

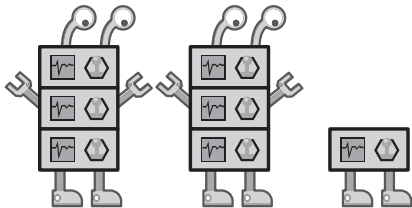

- 4 Donner uses a new recipe for trail mix. He uses $\frac{1}{8}$ cup of raisins, $\frac{2}{8}$ cup of pretzels, and $\frac{4}{8}$ cup of cashews. Does Donner have less than 1 cup, exactly 1 cup, or more than 1 cup of trail mix?

Explain your thinking.



- 5 A school orders 360 notebooks to share equally between 15 classrooms. How many notebooks will each classroom get? Show your thinking.

Did you show your thinking?



Name: _____

Date: _____

Adding and Subtracting Mixed Numbers with Common Denominators

- ① Circle the numbers that are composite.

9 4 13 12 65 17 42 19 2

- ② An artist has 3 meters of wire. How many centimeters long is the wire?

- ③ Subtract the mixed numbers by decomposing.

$$\begin{array}{r}
 7\frac{3}{5} \\
 - 1\frac{4}{5} \\
 \hline
 \end{array}
 \longrightarrow
 \left(\boxed{} + \begin{array}{|c|} \hline \\ \hline \\ \hline \end{array} + \begin{array}{|c|} \hline \\ \hline \\ \hline \end{array} \right)
 \longrightarrow
 \begin{array}{r}
 6\begin{array}{|c|} \hline \\ \hline \\ \hline \end{array} \\
 - 1\frac{4}{5} \\
 \hline
 \begin{array}{|c|} \hline \\ \hline \\ \hline \end{array}
 \end{array}$$

- ④ Add and subtract the mixed numbers using a strategy of your choice. Show your work.

a) $4\frac{2}{6} + 3\frac{5}{6} = \boxed{}$

b) $6\frac{1}{4} - 2\frac{2}{4} = \boxed{}$

Name: _____

Date: _____



Using Fraction Benchmarks to Estimate Sums and Differences

1 Round 98.348 to the nearest **tenth**.

2 Use $>$, $<$, or $=$ to make this statement true.

$$220.78 \bigcirc (2 \times 100) + (2 \times 10) + (7 \times \frac{1}{10}) + (8 \times \frac{1}{100})$$

3 Use the number line to show your estimate for $1\frac{2}{3} + 2\frac{5}{6}$.

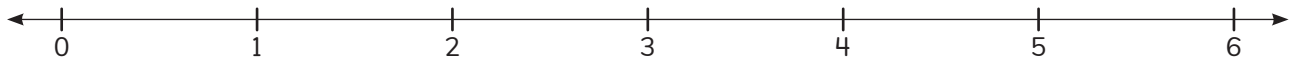

4 Use the number line to show your estimate for $3\frac{1}{2} - 1\frac{3}{4}$.

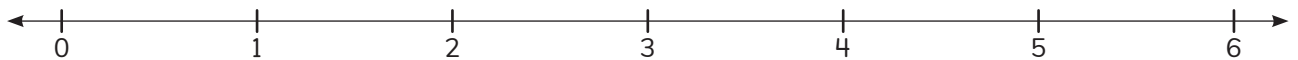

Dani has a box of 138 nails on her workbench. She places 11 more boxes of nails on the workbench. Each box contains 45 nails. About how many nails does Dani have on her workbench now? Estimate to find your answer. Show your thinking.

Did you show your thinking?



Name: _____

Date: _____



Mateo

Adding and Subtracting Fractions with Related Denominators

- 1 What is the volume of this shape?

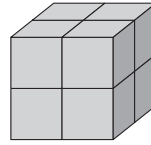

- 2 Use $>$, $<$, or $=$ to make this statement true.

$$\frac{4}{6} \bigcirc \frac{8}{12}$$

- 3 Find the sum.

$$\frac{1}{2} + \frac{5}{6} = \left\{ \begin{array}{c} \square \\ \square \end{array} \right.$$

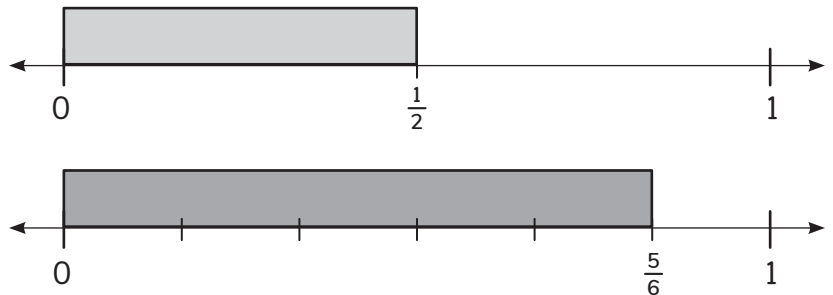

- 4 Find the difference.

$$\frac{3}{4} - \frac{1}{8} = \left\{ \begin{array}{c} \square \\ \square \end{array} \right.$$

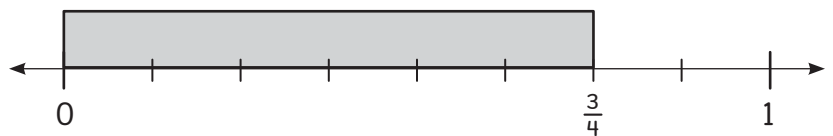

- 5 Mateo's dog, Arturito, drinks 0.4 liter of water every day for 7 days. How many milliliters of water does Arturito drink during the 7 days? Show your thinking.

Did you show your thinking?



Name: _____

Date: _____

Finding a Common Denominator with Related Fractions

- 1 List the factor pairs of each number. Then, circle the factors that both numbers have in common.

a) factors of 12:

b) factors of 16:

- 2 List the first 8 multiples of each number. Then, circle the common multiples.

a) multiples of 6:

b) multiples of 8:

- 3 Use the models to show two different ways to make common denominators to add $\frac{2}{3} + \frac{2}{6}$.



$$\frac{\square}{\square} + \frac{\square}{\square} = \frac{\square}{\square}$$

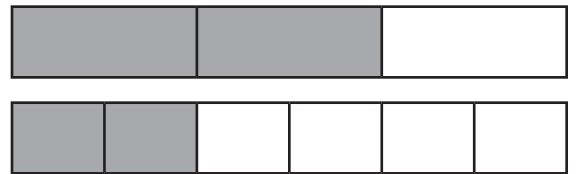

$$\frac{\square}{\square} + \frac{\square}{\square} = \frac{\square}{\square}$$

- 4 Add and subtract by writing equivalent fractions that have the same denominator. Show your work.

a) $\frac{5}{6} + \frac{4}{12} = \frac{\square}{\square}$

b) $\frac{9}{16} - \frac{1}{4} = \frac{\square}{\square}$

Name: _____

Date: _____

Adding and Subtracting Fractions and Mixed Numbers with Related Denominators

- 1 Write 42.567 in **expanded notation**.
- 2 Round 37.698 to the nearest **hundredth**.
- 3 Use common multiples or factors to add or subtract with equivalent fractions. Show your work.

a) $\frac{18}{20} - \frac{1}{5} - \frac{6}{10} =$

b) $2\frac{5}{6} + 1\frac{1}{3} + 4\frac{8}{12} =$

- 4 Use the model to complete and solve the equation.

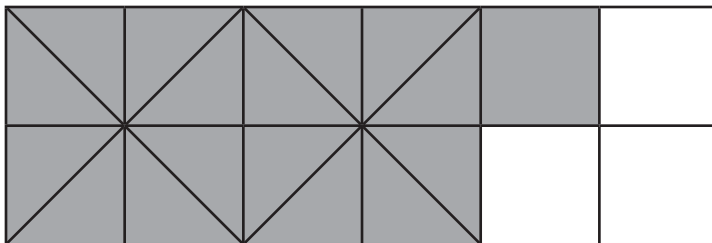

$$\begin{array}{|c|} \hline \\ \hline 12 \\ \hline \end{array} - \begin{array}{|c|} \hline \\ \hline 3 \\ \hline \end{array} = \begin{array}{|c|} \hline \\ \hline \\ \hline \end{array}$$

- 5 A baker has $\frac{1}{2}$ pound of raisins. She uses $\frac{3}{8}$ pound of the raisins for a recipe. How much does she have left? Show your work.

Did you show your work?



Name: _____

Date: _____



Choosing Strategies to Add and Subtract with Related Denominators

① Use the standard algorithm to solve.

$$23 \overline{) 8,349}$$

② Use the standard algorithm to solve.

$$\begin{array}{r} 782 \\ \times 26 \\ \hline \end{array}$$

③ Find the difference.

$$4\frac{1}{2} - 1\frac{1}{4} = \boxed{}$$

④ Find the sum.

$$3\frac{3}{4} + 1\frac{5}{8} = \boxed{}$$

⑤ Aleki and his uncle go on a three-day fishing trip. On the first day, they fish for $2\frac{3}{4}$ hours. On the second day, they fish for $3\frac{1}{2}$ hours. On the third day, they fish for $4\frac{3}{4}$ hours. How many hours do Aleki and his uncle fish in all? Show your thinking.

Did you show your thinking?



Name: _____

Date: _____



Using Dot Plots to Add and Subtract Mixed Numbers with Related Denominators

① Solve. $8\frac{1}{8} - \frac{3}{4} =$

$2\frac{1}{6} + 3\frac{2}{3} =$

② Find the volume of this rectangular prism.

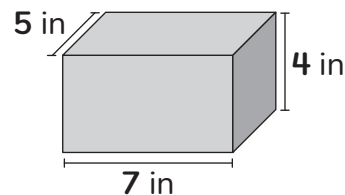

③ Aleki caught a wahoo fish that was $4\frac{3}{4}$ feet long and a giant trevally fish that was $5\frac{1}{2}$ feet long. Is the combined length of the fish less than, equal to, or greater than 10 feet?

④ a) Aleki arrived at his favorite fishing spot at 9:55 a.m. He spent 30 minutes fishing and did not catch any fish. He then walked for 15 minutes to another location. The fishing was so good there that he spent 2 hours and 45 minutes fishing. When Aleki looked at his watch, what time did he see?

b) Aleki's uncle will pick up Aleki at his current fishing spot at 2:00 p.m. How much longer can Aleki fish?

Name: _____

Date: _____

Finding a Common Denominator from Unrelated Denominators

- 1 Complete the comparison statement.

The value of the digit 4 in 3.24 is **one tenth ten times** as much as the value of the digit 4 in 0.324.

- 2 Below each expression, write a common denominator that you could use to help you add or subtract.

$$\frac{1}{3} + \frac{4}{6}$$

$$\frac{1}{2} + \frac{3}{5}$$

$$\frac{5}{6} - \frac{3}{4}$$

- 3 Use the models to find equivalent fractions with common denominators. Then add.

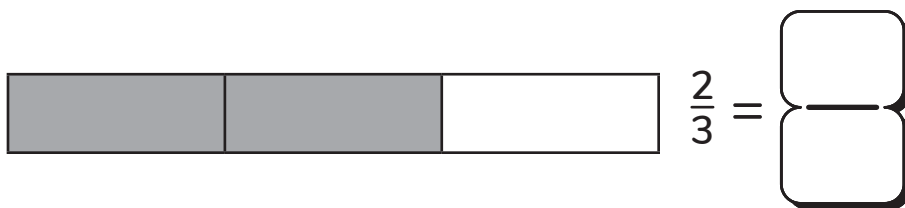
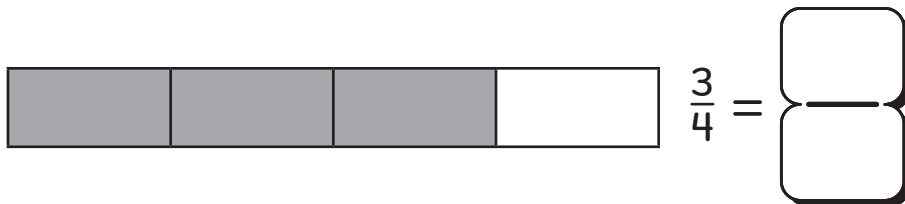

$$\frac{3}{4} + \frac{2}{3}$$

$$= \quad +$$

$$=$$

- 4 Use the models to find equivalent fractions with common denominators. Then subtract.

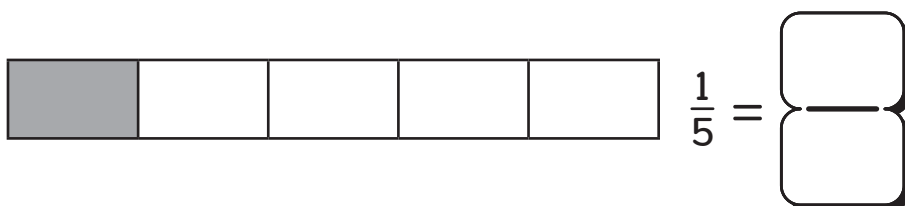
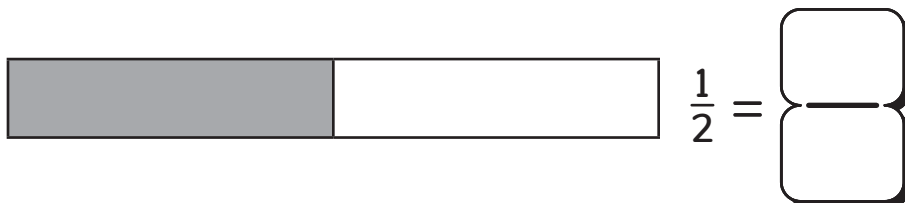

$$\frac{1}{2} - \frac{1}{5}$$

$$= \quad -$$

$$=$$

Name: _____

Date: _____



Adding and Subtracting Fractions with Unrelated Denominators

Aleki

① Use the standard algorithm to solve.

$$18 \overline{) 8,172}$$

② Use the standard algorithm to solve.

$$\begin{array}{r} 981 \\ \times 43 \\ \hline \end{array}$$

③ Solve.

$$\frac{5}{6} - \frac{3}{4} = \square$$

$$\frac{2}{3} + \frac{1}{2} = \square$$

④ Aleki caught a fish that was $\frac{7}{8}$ of a pound. His uncle caught a fish that was $\frac{1}{2}$ pound. How much more did Aleki's fish weigh than his uncle's fish?

Name: _____

Date: _____

Adding and Subtracting More Than Two Fractions

- ① Write each decimal as an equivalent fraction with 10 or 100 in the denominator.

$0.63 = \boxed{}$

$0.4 = \boxed{}$

$1.27 = \boxed{}$

- ② Write each fraction as an equivalent decimal.

$\frac{5}{10} = \boxed{}$

$\frac{98}{100} = \boxed{}$

$\frac{240}{100} = \boxed{}$

- ③ a) Estimate the sum of $\frac{5}{12} + \frac{7}{8} + 0.25$ and explain your thinking.

- b) Use common denominators to find the exact sum.

$$\boxed{} + \boxed{} + \boxed{} = \boxed{}$$

- c) Was your estimate close to your exact answer? Explain how you know.

- ④ Three friends worked together to make a fruit salad. The first friend cut up $\frac{4}{5}$ pound of watermelon. The second friend cut up $\frac{3}{4}$ pound of strawberries. The third friend cut up 0.6 pound of kiwi fruit.

- a) Estimate: Will the total weight of the fruit salad be more or less than 2 pounds? Explain how you know.

- b) Find the exact weight of fruit salad that they made. Show your work.

Name: _____

Date: _____



Louis



Dani

Adding and Subtracting Mixed Numbers with Unrelated Denominators

1

Find the sum.

$$3\frac{2}{5} + \frac{5}{8} + 5\frac{1}{4} = \square$$

2

Solve.

$$\frac{3}{4} + \frac{2}{8} = \square$$

$$2\frac{1}{4} - 1\frac{1}{3} = \square$$

3

Find the missing numbers.

\square

$\frac{3}{4}$ $\frac{5}{8}$ $1\frac{3}{8}$

$\frac{1}{2}$ $\frac{7}{6}$

$\frac{31}{24}$ $1\frac{1}{4}$

\square \square

4

Dani has 3 packages of nails. Each package weighs 680 grams. How many kilograms of nails does Dani have?

Name: _____

Date: _____



Anjali



Mateo

Solving Word Problems Involving Fractions and Mixed Numbers

- 1 Round 12.458 to the nearest **hundredth**.

2 Solve. $\frac{4}{3} + \frac{7}{4} =$

- 3 Anjali wants to have a space of $4\frac{3}{4}$ inches between these photos. What is the total length she will need to have available on her wall for her photo gallery?

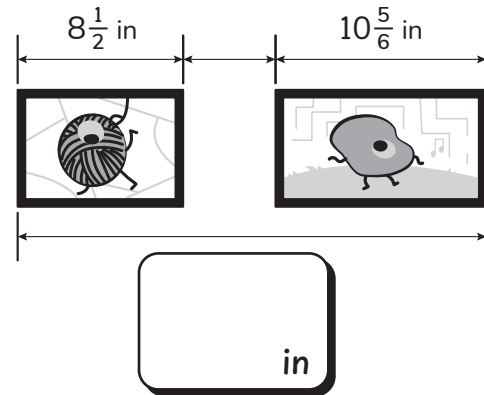

- 4 Mateo has a painting that is $14\frac{2}{3}$ inches tall. He has another painting that is $18\frac{3}{8}$ inches tall. What is the difference in height between these paintings?

- 5 Over the summer, Anjali and her family traveled from New York City to Los Angeles. They decided to go on a road trip and drive the 2,445 miles. On their first day, they left late and drove only 300 miles. They decided to drive the remaining part of their trip equally over 3 more days. How many miles do they need to drive each day? Solve with an equation, using a letter for the unknown.

Did you solve with an equation, using a letter for the unknown?



Topic 6

Extending Multiplication and Division to Fractions

Recommended ST Math Objectives:

Fraction Multiplication

Introduction to Fraction Division

Common Denominators and Equivalent Fractions

Name: _____

Date: _____



Anjali

Representing Non-Unit Fractions as Sums and Products of Unit Fractions

① Solve. $8\frac{1}{6} - \frac{3}{4} =$

$3\frac{2}{5} + 7\frac{2}{3} =$

② Write 2 equations that represent the model.

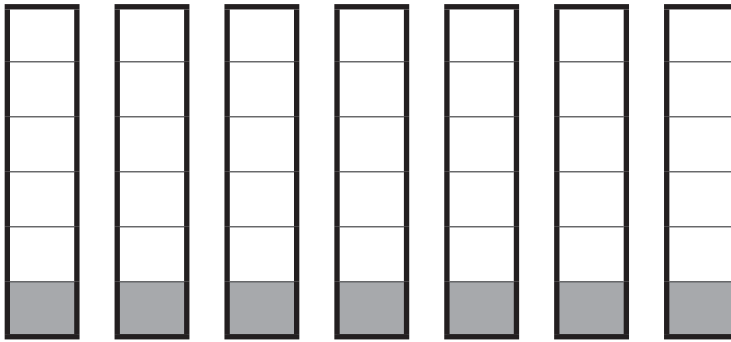

③ $3 \times \frac{1}{4} =$ + +

④ Anjali says $4 \times \frac{1}{5}$ and $\frac{1}{5} + \frac{1}{5} + \frac{1}{5} + \frac{1}{5}$ are equivalent expressions. Do you agree or disagree with Anjali? Explain your thinking.

Did you explain your thinking?



Name: _____

Date: _____

Using Number Lines to Model Unit Fractions Multiplied by Whole Numbers

① Use the standard algorithm to solve.

$$9 \overline{) 4,167}$$

② Use the standard algorithm to solve.

$$\begin{array}{r} 981 \\ \times 43 \\ \hline \end{array}$$

③ Use the number line to find the missing factor.

$$\boxed{} \times \frac{1}{5} = \frac{9}{5}$$

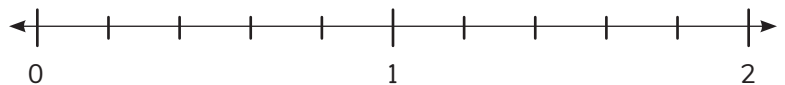

④ Finish the equation and represent it on the number line.

$$\frac{8}{3} = \boxed{} \times \begin{array}{c} \boxed{} \\ \boxed{} \end{array}$$



⑤ A critter partitioned a number line into sixths. It started at 0 and hopped 3 times. Each hop landed on the next tick mark on the number line. On what space on the number line did the critter land? What are 2 other numbers that could represent that spot on the number line? Show your thinking with a model and explain your thinking.

Did you show your thinking with a model and explain your thinking?



Name: _____

Date: _____



Dani



Brian

Modeling and Solving Non-Unit Fractions Multiplied by Whole Numbers

1 Dani cut $12\frac{3}{4}$ inches off a board that was $48\frac{1}{2}$ inches long.

a) How is the length of the remaining board written in mixed number form?

b) How is the length of the remaining board written in decimal form?

2 The circle is one whole.

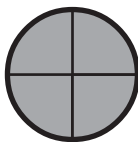

Circle the expressions that can be used to represent this quantity.

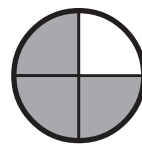
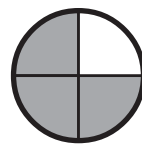
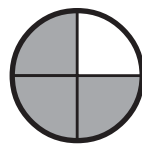
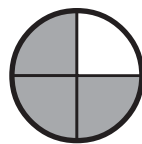
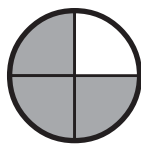
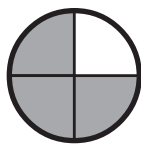

$$6 \times 3 \times \frac{1}{4}$$

$$3 \times \frac{3}{4}$$

$$18 \times \frac{1}{4}$$

$$6 \times \frac{3}{4}$$

3 Solve. $7 \times \frac{2}{3} =$

$$4 \times \frac{3}{4} =$$

4 Brian baked 36 muffins. $\frac{1}{3}$ of the muffins were blueberry muffins and $\frac{2}{3}$ of the muffins were banana muffins. How many muffins were blueberry muffins? How many muffins were banana muffins?

Name: _____

Date: _____



Donner

Discovering Patterns Involving Fractions Multiplied by Whole Numbers

- ① A pentagon and its side lengths are shown.
What is the perimeter of the pentagon in inches?

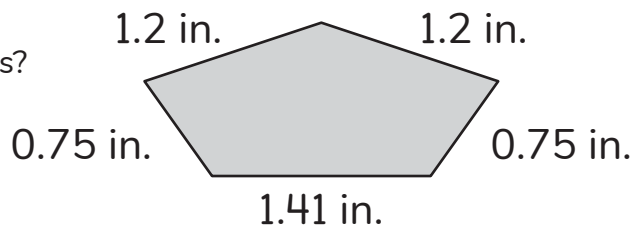

- ② Circle the composite numbers. 31 32 33 34 35

③ Model and solve. $2 \times \frac{3}{2} = \square$

- ④ The product of $8 \times \frac{7}{8}$ is equal to the numerator of the fraction.

True **False**

Explain your thinking.



- ⑤ Donner went on a $\frac{3}{4}$ -mile hike in the morning and 0.5-mile hike in the afternoon.
How far did Donner hike in all? Show your thinking with an equation.

Did you show
your thinking with
an equation?



Name: _____

Date: _____



Logan

Solving Word Problems Involving Fractions Multiplied by Whole Numbers

- 1 Write the number 420.351 in expanded notation.

3 Solve. $3\frac{1}{2} - \frac{4}{5} =$

$2\frac{2}{3} + 6\frac{3}{4} =$

- 3 Using Logan's recipe, how much honey will be needed to make 3 batches of lemonade?



Show your thinking with an equation.

Logan's Lemonade Recipe

Serves 8

$\frac{5}{2}$ cups of lemon juice

$\frac{2}{3}$ cup of honey

8 cups of water

Some ice cubes

Mint

4 Solve. $6 \times \frac{4}{5} =$ $3 \times \frac{4}{6} =$ $5 \times \frac{2}{3} =$

- 5 Logan wants to try a strawberry lemonade recipe. The recipe calls for $\frac{5}{6}$ cup strawberry puree for each batch of lemonade. If each batch is enough for 6 people, how many cups of strawberry puree does Logan need to serve 30 people? Explain your thinking.

Did you explain your thinking?



Name: _____

Date: _____



Logan

Modeling and Solving Mixed Numbers Multiplied by Whole Numbers

① Solve. $[2 \times (3 + 4)] - (3 \times 4) = \square$

② Finish the equation to represent this model and find the product.

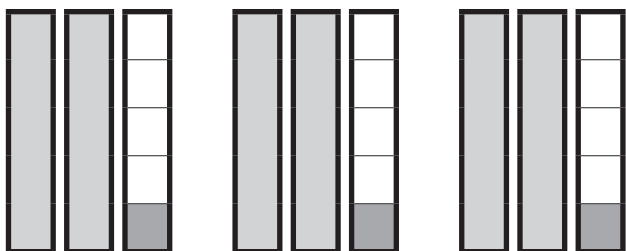

$$3 \times \square = \square$$

③ Rewrite this equation using parentheses and solve.

$$\begin{aligned}
 & 5 \times 3\frac{1}{2} \\
 &= 5 \times (\square + \square) \\
 &= (5 \times \square) + (5 \times \square) \\
 &= \square + \square \\
 &= \square
 \end{aligned}$$

④ Logan drank $3\frac{3}{4}$ quarts of water yesterday. She drank $2\frac{1}{3}$ quarts of water today. How many more quarts of water did she drink yesterday than today? Show your thinking with an equation.

Name: _____

Date: _____



Logan

Brian

Solving Word Problems Involving Mixed Numbers Multiplied by Whole Numbers

1 Write the number 27.509 in expanded notation.

2 Solve. $[7 \times (8 - 3)] + (2 \times 5) = \boxed{}$

3 a) Last week, Logan walked a path at the lake that is $2\frac{5}{8}$ miles long. She walked the same path each day for 5 days. How many miles did she walk?

Show your thinking with an equation.



b) This week, she walked a different path by the lake that is $3\frac{1}{4}$ miles long. She walked that path each day for 4 days. Did she walk farther this week or last week?



Explain your thinking.

4 Brian uses $3\frac{1}{4}$ cups of flour in each loaf of bread. How many cups of flour does Brian need in order to make 6 loaves of bread? Explain your thinking with an equation.

Did you explain your thinking with an equation?



Name: _____

Date: _____



Brian

Modeling and Solving Multiplicative Comparison Word Problems: Mixed Unknown

① Use the standard algorithm to solve.

② Use the standard algorithm to solve.

$$31 \overline{) 8,897}$$

$$\begin{array}{r} 217 \\ \times 85 \\ \hline \end{array}$$

③ A baby cheetah is $\frac{11}{12}$ foot long. An adult cheetah is 5 times as long as the baby cheetah. How long is the adult cheetah?

Write an equation and solve.



④ A rhino horn is $1\frac{2}{3}$ feet long. An elephant tusk is 4 times as long as the rhino horn. How long is the elephant tusk?

Write an equation and solve.



⑤ Brian is making bread. The recipe he is using calls for $\frac{1}{2}$ jar of sesame seeds. Brian had 1 whole jar of sesame seeds yesterday, but he used $\frac{4}{6}$ of the jar to make muffins. Are there enough sesame seeds left for the bread recipe? Explain your thinking.

Did you explain your thinking?



Name: _____

Date: _____



Leilah

Using Visual Models to Find Fractional Parts of Whole Numbers

1 A race is 5,000 meters long. How long is the race in kilometers?

2 Write an expression to represent “multiply the sum of 11 and 14 by 6.”

3 Use the model to find $\frac{1}{3}$ of 6.

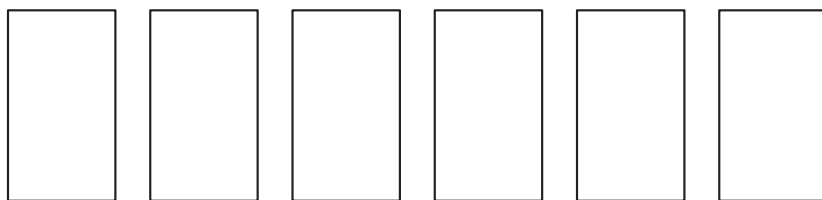

$$\frac{1}{3} \times 6 = \boxed{}$$

4 Solve.

$$\frac{1}{6} \times 18 = \boxed{}$$

$$\frac{1}{5} \times 20 = \boxed{}$$

$$\frac{1}{3} \times 3 = \boxed{}$$

$$\frac{1}{4} \times 8 = \boxed{}$$

$$\frac{1}{2} \times 10 = \boxed{}$$

$$\frac{1}{9} \times 9 = \boxed{}$$

5 Leilah made 8 tarts for a bake sale.

a) She put $\frac{1}{2}$ cup of blueberries in each tart. Draw a model and write a multiplication equation to show how many cups of blueberries she used in all.

b) Leilah sold $\frac{1}{2}$ of her tarts at the bake sale. Draw a model and write a multiplication equation to show how many tarts she sold.

Name: _____

Date: _____



Using Visual Models to Find Non-Unit Fractional Parts of Whole Numbers

1 If $\frac{2}{3} \times 6 = n$, is n greater than or less than 6? Explain your thinking.

2 Vivi is making 6 picture frames as gifts for her family. She will put stickers on $\frac{2}{3}$ of the picture frames. Use the model to represent the situation and complete the equation.

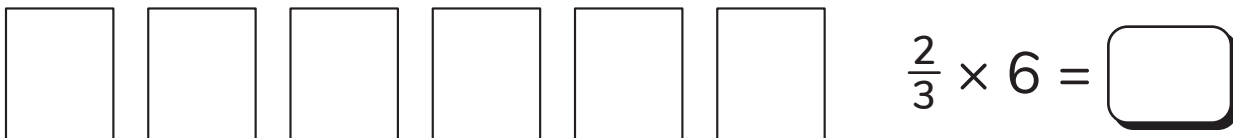

3 Circle the expressions that could be used to find the product of $\frac{2}{3} \times 6$.

$(\frac{1}{3} \times 6) \times 2$
 $(\frac{1}{3} \times 2) \times 6$
 $2 \times 3 \times 6$
 $(2 \times 6) \times \frac{1}{3}$

4 Solve.

$$\frac{1}{2} \times 14 = \square$$

$$\frac{3}{5} \times 20 = \square$$

$$\frac{2}{5} \times 5 = \square$$

$$\frac{2}{4} \times 8 = \square$$

$$\frac{5}{6} \times 18 = \square$$

$$\frac{6}{7} \times 7 = \square$$

5 A student says, "When you multiply a fraction by a whole number, if the whole number is the same as the denominator of the fraction, the product will be the numerator of the fraction. For example, $\frac{3}{4} \times 4 = 3$." Do you agree? Explain your thinking.

Did you explain your thinking?



Name: _____

Date: _____



Modeling and Solving Word Problems Involving Fractions

Naomi

Aleki

① Use the standard algorithm to solve.

$$43 \overline{) 5,848}$$

② Use the standard algorithm to solve.

$$\begin{array}{r} 425 \\ \times 37 \\ \hline \end{array}$$

③ Naomi collected 8 bags of trash at 3 parks.

a) At the first park, she collected $1\frac{3}{8}$ bags of trash. At the second park, she collected 3 times as much trash as she did at the first park. How many bags of trash did Naomi collect at the second park?

b) How many bags of trash did Naomi collect at the third park?

④ Aleki is helping to set up a party to celebrate after his school band concert. He needs to set up 18 tables. $\frac{1}{6}$ of these tables will be used to serve food for the party. How many tables will be used to serve food? Show your thinking with an equation.

Did you explain your thinking with an equation?



Name: _____

Date: _____



Exploring Division Types with Whole Numbers and Fractions

① $[6 + (8 \times 3)] \div 15 = \boxed{}$

- ② Find the volume.

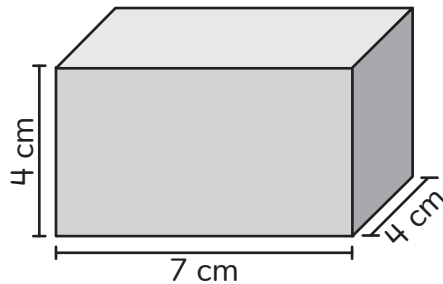

- ③ Brian used 2 cups of flour when baking 5 batches of cookies. He used the same amount of flour in each batch. How much flour did Brian use in each batch?

- ④ There are 9 gallons of water. A fish tank can hold 10 gallons. How many fish tanks can be filled?

Name: _____

Date: _____



Dividing Unit Fractions by Whole Numbers

- ① Circle the prime numbers.

2 15 33 5

11 108 19 45

- ② Find the sum.

$$1\frac{3}{8} + \frac{3}{2} = \boxed{}$$

- ③ Vivi has $\frac{1}{3}$ of a jar of beads. She wants to share the beads equally between 4 necklaces. How much of a jar of beads will each necklace use? Draw a model and write an equation to represent the situation.



- ④ Solve.

$$\frac{1}{2} \div 4 = \boxed{}$$

$$\frac{1}{3} \div 2 = \boxed{}$$

$$\frac{1}{5} \div 5 = \boxed{}$$

$$\frac{1}{6} \div 3 = \boxed{}$$

- ⑤ A student says, "When I divide a unit fraction by a whole number, I can use multiplication to find the denominator." Explain what she means. Use an example if it will help you explain.

Name: _____

Date: _____



Dani

Identifying Patterns When Dividing Unit Fractions by Whole Numbers

- ① Put a sign in this equation to make it true.

$$68.25 \bigcirc 10 = 6.825$$

- ② Solve.

$$\frac{5}{6} + \frac{7}{9} =$$

- ③ Circle the expression that will have the greatest quotient. Explain your thinking.

$$\frac{1}{3} \div 3$$

$$\frac{1}{3} \div 5$$

$$\frac{1}{3} \div 7$$

Did you explain your thinking?



- ④ Dani is cutting another board for her project. If she has a $\frac{1}{3}$ meter board and cuts it into 2 pieces, what will be the length of each piece? Draw a model to show your thinking.

- ⑤ Dani now wants to cut a $\frac{1}{2}$ meter board into 2 equal pieces. How long will each piece be?

Name: _____

Date: _____



Dividing Whole Numbers by Unit Fractions

- ① There are 3 cups of chocolate milk. If the chocolate milk is shared equally by 4 students, how much will each student get?

② Solve. $\frac{8}{9} - \frac{3}{4} =$

$\frac{2}{3} + \frac{3}{4} + \frac{1}{8} =$

- ③ Louis has 8 pints of juice to serve with his lasagna. If each serving of juice is $\frac{1}{4}$ pint, how many servings does Louis have?

④ Find the quotient. $8 \div \frac{1}{3} =$

- ⑤ Brian has 8 pounds of flour. If he uses $\frac{1}{10}$ pound of flour for each bread roll, how many bread rolls can Brian make?

Name: _____

Date: _____



Dani

Mateo

Relating Division by Unit Fractions to Multiplication by Whole Numbers

① Round 189.771 to the nearest hundredth.

② Dani had $\frac{1}{3}$ of a pizza left over from a party. If 4 people share the leftover pizza equally, how much of the original pizza will each person get?

③ If each square represents one whole, what expressions are shown in this model?

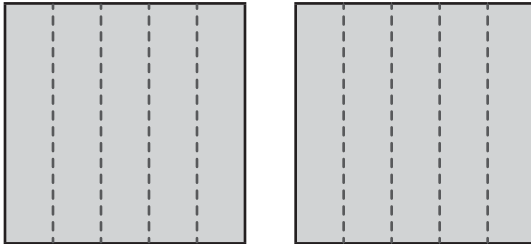

④ Find the quotient.

$$6 \div \frac{1}{3} = \text{$$

⑤ Mateo has 4 cans of blue paint. His design needs $\frac{1}{3}$ of a can for each canvas. How many canvases can he paint?

Name: _____

Date: _____



Exploring Patterns When Dividing Whole Numbers by Unit Fractions

- ① Circle the expression with a greater value. $\frac{1}{6} \times 3$ $\frac{1}{6} \times 4$

- ② Mateo painted 5 tables. He used $4\frac{2}{3}$ cups of paint for each table. How much paint did Mateo use in all? Explain your thinking.

- ③ Which expression has a greater value? Explain your thinking. $5 \div \frac{1}{8}$ $5 \div \frac{1}{4}$

Did you explain your thinking?

- ④ Use $>$, $<$, or $=$ to make the statement true.

$$3 \div \frac{1}{2} \bigcirc 6$$

- ⑤ There are 3 pizzas. If each person gets $\frac{1}{3}$ of a pizza, how many people can share the pizzas?

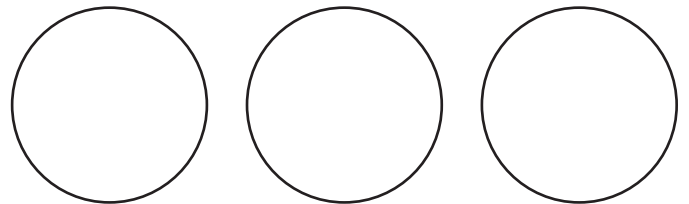

Name: _____

Date: _____



Solving Real-World Problems with Fraction Multiplication and Division

① Write the number 981.407 in expanded notation.

② Find the quotient.

$$2 \div \frac{1}{4} =$$

$$5 \div 8 =$$

③ Complete the equation.

$$6 \div \frac{1}{3} = 6 \times$$

$$3 \div 4 = 3 \times$$

④ Brian has 4 cups of oatmeal. If he uses $\frac{1}{2}$ cup of oatmeal for each serving, how many servings can Brian make? Show your thinking with an equation.

Did you show your thinking
with an equation?



Name: _____

Date: _____



Solving Problems with Fractions and Four Operations

① Use $>$, $<$, or $=$ to compare. 814.246 ○ 814.462

② The lap lane at the pool is open for 6 hours each day. If each person gets $\frac{1}{4}$ of an hour to swim laps, how many swimmers can use the lap lane each day?

③ Mateo's dog, Arturito, had $5\frac{1}{8}$ cups of water in his bowl. If he drank $1\frac{1}{2}$ cups of water, how much water remains in the bowl? Explain your thinking.

④ $1\frac{3}{4} \times 4 =$

⑤ Each lap in the swimming pool is 25 meters long. You want to swim a kilometer. How many laps do you need to swim in order to swim a kilometer? 35, 40, or 45 laps? Explain your thinking.

Did you explain your thinking?



Topic 7

Extending Multiplication and Division to Decimals

Recommended ST Math Objectives:

Multiplying with Decimals

Dividing with Decimals

Decimal Place Value

Name: _____

Date: _____

Connecting Fraction Multiplication to Decimal Multiplication

- 1 Represent the value of each model as a fraction (or mixed number) and as a decimal.

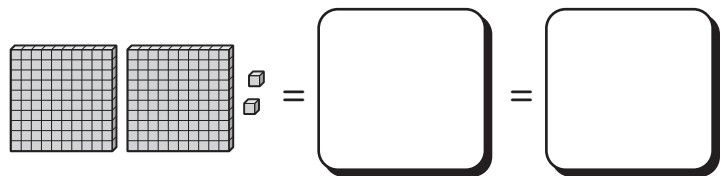
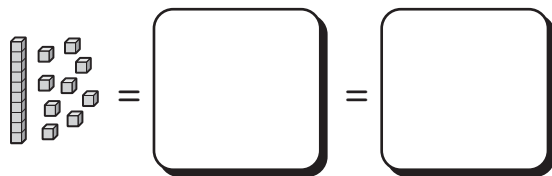
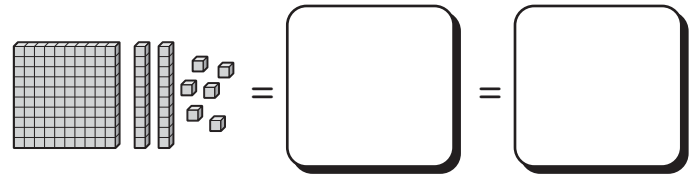
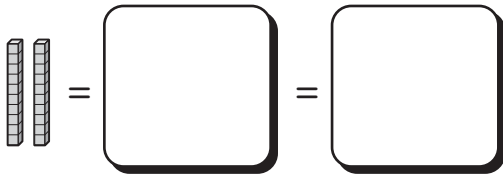
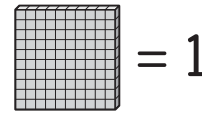

- 2 Draw base ten blocks to model and solve each problem.

a) $3 \times 0.15 =$

b) $3 \times 0.41 =$

- 3 Multiply using hops on the number line.

$4 \times 0.4 =$ ←————→

- 4 a) Will the product of 40×0.6 be greater than or less than 0.6? Explain your thinking.

Did you explain your thinking?

- b) Will the product of 40×0.6 be greater than or less than 40? Explain your thinking.

Did you explain your thinking?

Name: _____

Date: _____



Discovering Place Value Patterns in Decimal Multiplication

- 1 Vivi brought 6 quarts of apple cider to a picnic. Her friends drank half of the apple cider. How many quarts of apple cider did Vivi's friends drink?

- 2 Circle the expression that has the greatest value.

$$\frac{1}{8} \times 8$$

$$\frac{1}{8} \div 8$$

$$8 \div \frac{1}{8}$$

- 3 Complete the pattern.

$$15 \times 10 = \boxed{}$$

$$15 \times 1 = \boxed{}$$

$$15 \times 0.1 = \boxed{}$$

$$15 \times 0.01 = \boxed{}$$

- 4 Is the missing factor 0.1 or 0.01?

$$18 \times \boxed{} = 0.18$$

$$46 \times \boxed{} = 4.6$$

$$75 \times \boxed{} = 0.75$$

- 5 Vivi says that the missing factor in $35 \times \square = 0.35$ is 0.1. Do you agree or disagree with Vivi? Explain your thinking.

Did you explain your thinking?



Name: _____

Date: _____

Using Factoring to Multiply Decimals

- ① Find the volume.

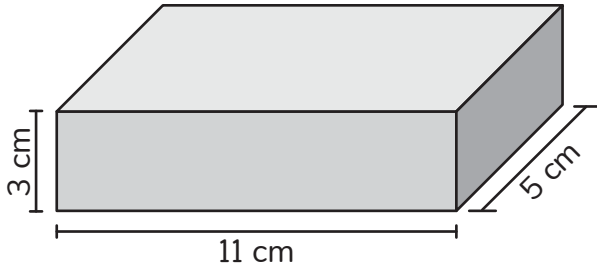

- ② Solve.

$$\frac{1}{3} \div 4 = \boxed{}$$

- ③ Circle the expressions that represent 5×0.7 .

$5 \times (7 \times 0.1)$ $5 \times (7 \times 0.01)$ 5×7 hundredths 5×7 tenths

- ④ Factor to solve. Then, draw a model of base ten blocks to check your work.

$$3 \times 0.26 = \boxed{}$$

Did you show your work?



Name: _____

Date: _____



Estimating Products of Decimals and Two-Digit Whole Numbers

Brian

- 1 Brian baked a baguette that had a length of 3 feet. He cut the baguette into pieces that were each $\frac{1}{4}$ foot long. How many pieces did Brian cut? Explain your thinking.

Did you explain your thinking?

2 Solve. $\frac{5}{6} - \frac{6}{8} =$

- 3 The product of 46×0.72 is greater than 46.
Explain your thinking.

True

False

Did you explain your thinking?

- 4 Find the product.

$$53 \times 0.18 = \text{$$

$$37 \times 0.62 = \text{$$

Name: _____

Date: _____

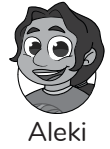

Multiplying Decimals by Two-Digit Whole Numbers to Solve Word Problems

Aleki

① Write the number 72.921 in expanded notation.

② Solve. $9 \div \frac{1}{4} =$

③ Is the product of 30×0.4 greater than or less than 30? Explain your thinking.

Did you explain your thinking?

④ What is the value of the expression $9 \times (5 \times 0.01)$?

⑤ Aleki wants to buy fishing sinkers that each weigh 0.05 pounds. If he buys 25 sinkers, what is their total weight?

Name: _____

Date: _____

Using Area Models to Multiply Tenths by Tenths

1 Solve. $0.8 \times 7 = \square$

2 Label the model with decimals. Then, write an equation to represent the model.

$$\square \times \square = \square$$

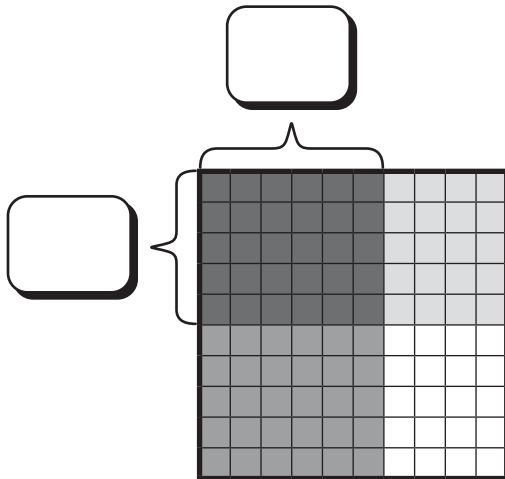

3 Use the area model to find the product of 0.3×0.6 .

$$\square$$

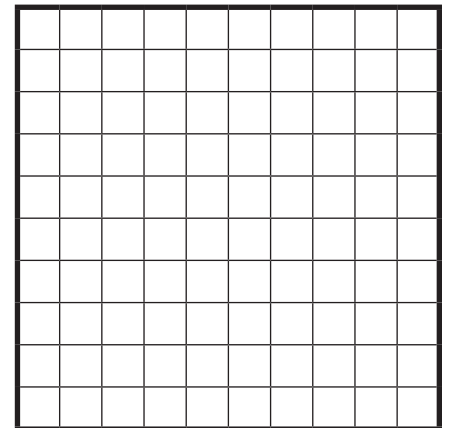

4 A runner has a water bottle with 0.9 liters of water. During the race, he drinks 0.7 of his water bottle. How much water does he drink during the race? Show your thinking with a model and an equation.

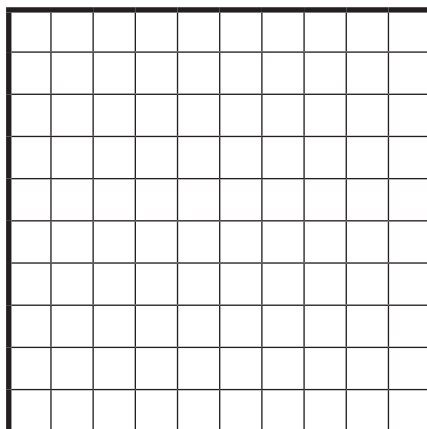

Did you show your thinking?



Name: _____

Date: _____

Exploring Strategies for Multiplying Ones and Tenths by Tenths

- ① Solve.

$$4 \times \frac{1}{8} = \boxed{}$$

$$4 \times \frac{1}{4} = \boxed{}$$

- ② Use $<$, $>$, or $=$ to compare.

$$\frac{2}{3} \bigcirc \frac{2}{4}$$

$$0.75 \bigcirc \frac{3}{4}$$

$$0.6 \bigcirc 0.06$$

- ④ A baker used 2.5 packets of yeast in a recipe. Each packet contained 0.7 ounces of yeast. How many ounces of yeast did the baker use in all? Show your thinking with a model and by factoring with equations.

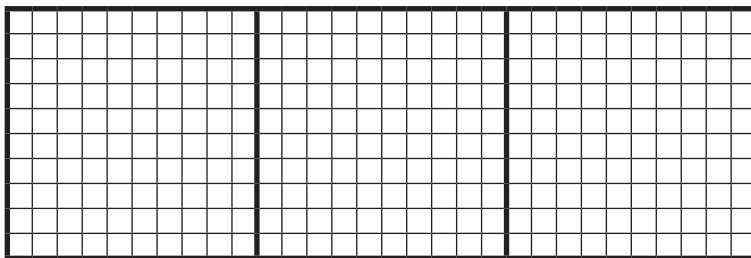

- ③ Label the model to show the multiplication steps. Then, complete the equations to show the same steps using partial products.

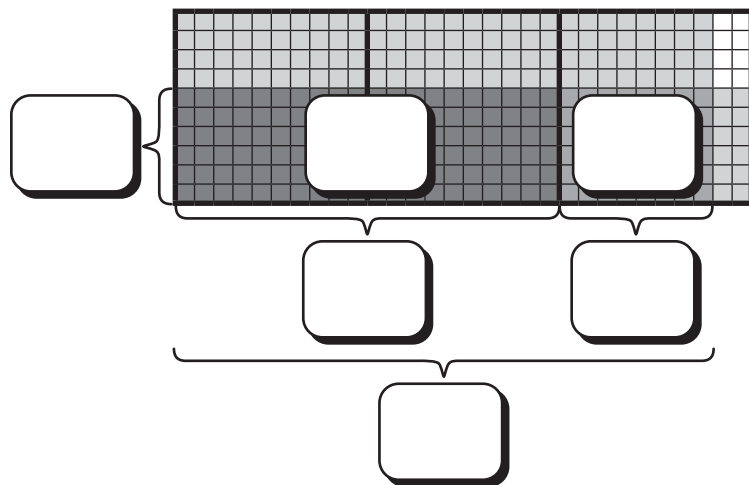

$$\begin{aligned} & (\boxed{} \times \boxed{}) \\ = & (\boxed{} \times \boxed{}) + (\boxed{} \times \boxed{}) \\ = & \boxed{} + \boxed{} \\ = & \boxed{} \end{aligned}$$

Did you show your thinking?

Name: _____

Date: _____

Exploring Strategies to Multiply Decimals

- 1 Complete the equations.

$4 \times 0.1 = \square$

$30 \times 0.1 = \square$

$12 \times \square = 0.12$

$6 \times 0.01 = \square$

$5,200 \times 0.01 = \square$

$73 \times \square = 7.3$

- 2 Label the model. Then, complete the equations to represent the partial products with equations.

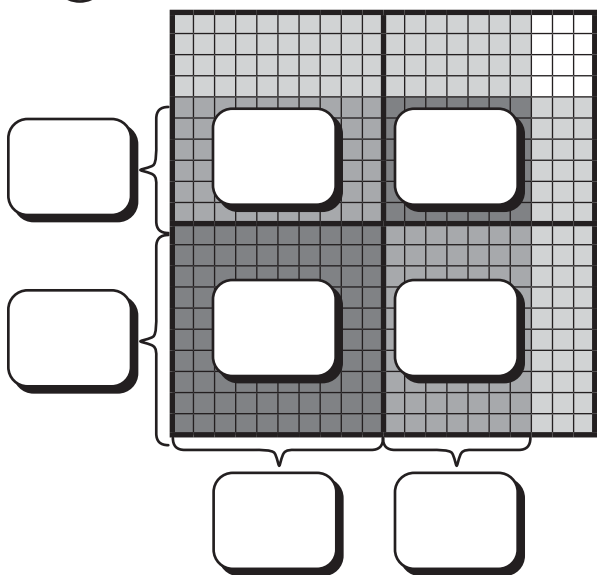

$$\begin{aligned}
 & (\square \times \square) \\
 = & (\square \times \square) + (\square \times \square) \\
 & + (\square \times \square) + (\square \times \square) \\
 = & \square + \square + \square + \square \\
 = & \square
 \end{aligned}$$

- 3 a) Estimate: 3.8×2.4 is about $\square \times \square = \square$.

- b) Solve by factoring. Show your work.
You may want to use partial products or the standard algorithm to multiply whole numbers.

3.8×2.4

$= (38 \times 0.1) \times (\square \times \square)$

- c) Do your estimate and your answer make sense together? Explain your thinking.

$= (\square \times \square) \times (0.1 \times 0.1)$

$= \square \times \square$

$= \square$

Did you show your thinking?



Name: _____

Date: _____

Solving Word Problems with Decimal Multiplication

- ① Solve.

$13.83 + 2.17 = \boxed{}$

$18.23 - 5.37 = \boxed{}$

- ② Find the quotient. $3,936 \div 24 = \boxed{}$

- ③ A bouncy ball costs \$0.87. What is the cost of 24 bouncy balls?

Estimate: $\boxed{} \bigcirc \boxed{}$ is about $\boxed{} \bigcirc \boxed{} = \boxed{}$.

Use the open area model to solve.

- ④ A bread recipe uses 3.5 cups of flour for 1 batch of bread. How many cups of flour are needed to make 2.5 batches of bread?

Estimate: $\boxed{} \bigcirc \boxed{}$ is about $\boxed{} \bigcirc \boxed{} = \boxed{}$.

Solve. Show your thinking.

Did you show your thinking?



Name: _____

Date: _____



Solving Multistep Problems with Decimal Expressions

- 1 Is the product of 3×1.1 greater than or less than 3?

Explain your thinking.



- 2 Complete each equation.

$$\boxed{} + 3.6 = 7$$

$$5.8 + \boxed{} = 10.7$$

- 3 Circle the expression that is equivalent to the expression $4[3 + (2.5 \times 1.6)] - 7$.

$$12 + (2.5 \times 1.6) - 7 \quad 4[3 + (4.00)] - 7 \quad 4[5.5 \times 1.6] - 7$$

- 4 Aleki shopped at a bookstore.

- He bought 3 paperback novels for \$7.20 each.
- He used a coupon for \$1.50 off the price of each novel.
- He also bought a notebook for \$5.35 and a pen set for \$3.75.
- Then, he used a coupon for \$4.00 off the entire purchase.

Circle the expression that correctly represents the situation. Then, simplify the expression to find the cost of the entire purchase.

$$[3(7.20 - 1.50) + 5.35 + 3.75] - 4.00$$

$$[3(7.20) - 1.50 + 5.35 + 3.75] - 4.00$$

Name: _____

Date: _____

Using Unit Square Models and Equivalent Fractions to Divide Whole Numbers with Decimal Quotients

- ① Solve.

$$\begin{array}{r} 334.2 \\ - 128.04 \\ \hline \end{array}$$

- ② Write the equivalent decimal.

$\frac{9}{10} = \boxed{}$

$\frac{27}{100} = \boxed{}$

$\frac{6}{100} = \boxed{}$

- ③ Model each division expression. Then, write the value of each expression as a fraction, as an equivalent fraction with 10 or 100 as the denominator, and as a decimal.

$1 \div 4$

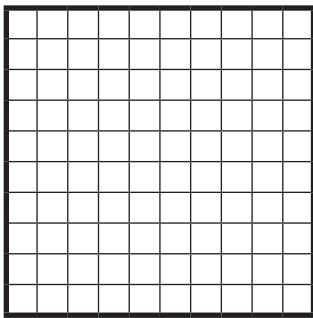

$1 \div 4 = \frac{\boxed{}}{\boxed{}} = \frac{\boxed{}}{\boxed{}} = \boxed{}$

$2 \div 5$

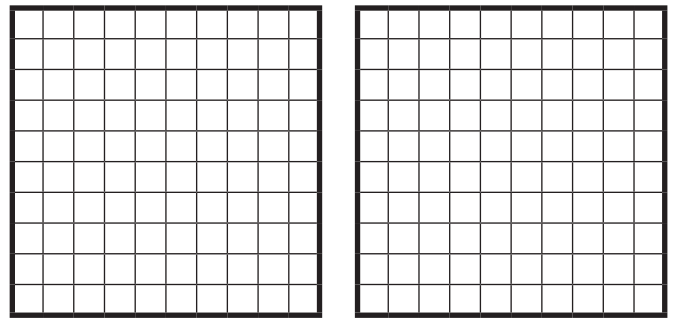

$2 \div 5 = \frac{\boxed{}}{\boxed{}} = \frac{\boxed{}}{\boxed{}} = \boxed{}$

- ④ a) Complete the equations with fractions and decimals.

$3 \div 5 = \frac{\boxed{}}{\boxed{}} = \frac{\boxed{}}{\boxed{}} = \boxed{}$

$3 \div 4 = \frac{\boxed{}}{\boxed{}} = \frac{\boxed{}}{\boxed{}} = \boxed{}$

- b) When you divide 2 whole numbers to get a decimal, how can you predict whether the last digit will be in the tenths place or the hundredths place?

Name: _____

Date: _____

Investigating Repeating Decimal Patterns

- ① Write the value of the 7 in each number.

462.79

384.57

- ② Complete the equations with fractions and decimals.

$3 \div 4 = \frac{\boxed{}}{\boxed{}} = \frac{\boxed{}}{\boxed{}} = \boxed{}$

$3 \div 5 = \frac{\boxed{}}{\boxed{}} = \frac{\boxed{}}{\boxed{}} = \boxed{}$

- ③ Use the models to find the decimal quotients.

$1 \div 5 = \boxed{}$

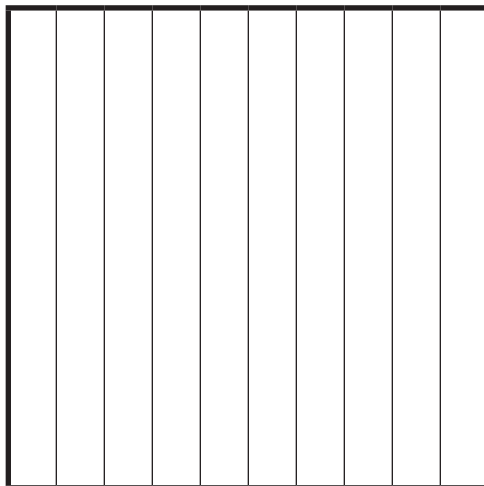

$1 \div 4 = \boxed{}$

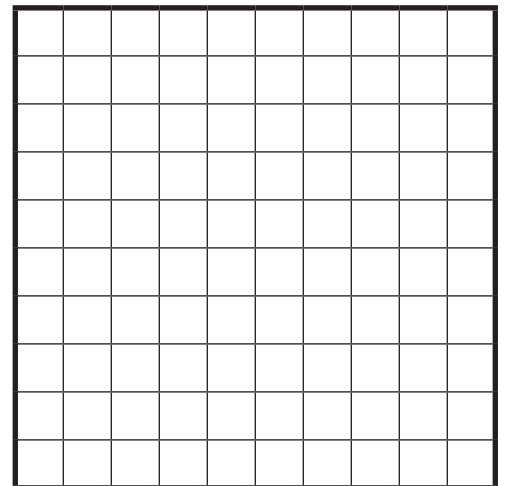

Name: _____

Date: _____

Using Place Value Relationships to Divide Whole Numbers with Decimal Quotients

① Multiply.

$$3.7 \times 4.2 = \boxed{}$$

② Solve.

$$28.62 + 15.09 = \boxed{}$$

③ Complete the equations.

$$100 \div 5 = \boxed{}$$

$$300 \div 4 = \boxed{}$$

$$10 \div 5 = \boxed{}$$

$$30.0 \div 4 = \boxed{}$$

$$1.0 \div 5 = \boxed{}$$

$$3.00 \div 4 = \boxed{}$$

$$10 \text{ tenths} \div 5 = \boxed{\text{tenths}}$$

$$300 \text{ hundredths} \div 5 = \boxed{\text{hundredths}}$$

④ Divide by thinking about each dividend with tenths or hundredths. Show your work.

$$2 \div 5 = \boxed{}$$

$$2 \div 8 = \boxed{}$$

Did you show your work?



⑤ A pitcher holds 3 liters of water. If the water is shared equally between 5 glasses, how much water will be in each glass? Write your answer as a decimal. Show your thinking.

Did you show your thinking?



Name: _____

Date: _____

Using the Standard Algorithm to Divide Whole Numbers with Decimal Quotients

- ① Solve.

$$\frac{5}{6} + \frac{2}{3} = \boxed{}$$

$$\frac{4}{5} - \frac{1}{4} = \boxed{}$$

- ② Draw a quadrilateral with 4 equal sides and no right angles. What is the name of your shape?

- ③ Solve using the standard algorithm.

$$6 \overline{) 939}$$

$$25 \overline{) 1,926}$$

- ④ During the summer, a farmer makes 2,356 ounces of blueberry jam to sell. How many 8-ounce jars can the farmer fill with blueberry jam? Show your work.

Did you show your work?



Name: _____

Date: _____

Using Unit Square Models and Place Value Relationships to Divide Decimals by Whole Numbers

① Simplify. $6(5 - 3) \times 2 \div 4$

② Divide. $4 \overline{)239}$

③ Complete the equations.

$80 \div 4 = \boxed{}$

$8.0 \div 4 = \boxed{}$

$0.8 \div 4 = \boxed{}$

$0.08 \div 4 = \boxed{}$

$70 \div 2 = \boxed{}$

$7.0 \div 2 = \boxed{}$

$0.70 \div 2 = \boxed{}$

④ Use place value words to solve. Place a 0 at the end of the dividend if you need to.

$3.0 \div 5 = \boxed{}$

$30 \boxed{} \div 5 = \boxed{}$

$0.3 \div 2 = \boxed{}$

$30 \boxed{} \div 2 = \boxed{}$

⑤ A bag contains 0.4 pounds of sunflower seeds. If 5 people share the sunflower seeds equally, how much will each person get? Show your work.

Did you show your work?



Name: _____

Date: _____



Anjali

Using Decomposition Strategies to Divide Decimals by Whole Numbers

- 1 Anjali's class has a new challenge to read for 6 hours in 1 week. Has Anjali already met the class goal for the week?

Anjali's Reading Log (hours)	
Monday	$2\frac{1}{3}$
Tuesday	$1\frac{1}{2}$
Wednesday	$1\frac{1}{4}$

- 2 Model with base-10 blocks. Then shade in the model below. Use the equations with decomposition to solve.

$$11.55 \div 11 = \boxed{}$$

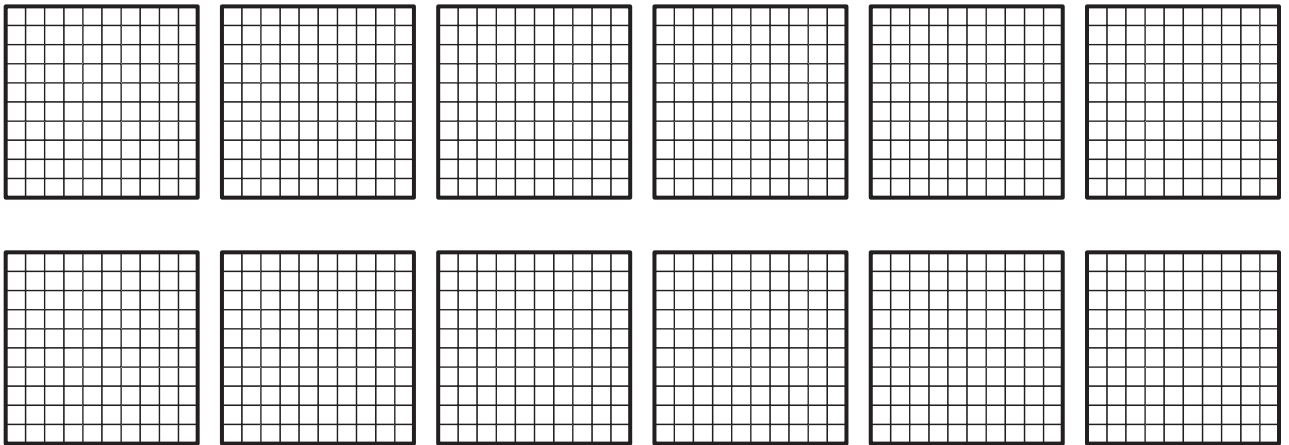

$$\begin{aligned}
 11.55 \div 11 &= (\boxed{} \div \boxed{}) + (\boxed{} \div \boxed{}) \\
 &= \boxed{} + \boxed{} \\
 &= \boxed{}
 \end{aligned}$$

Name: _____

Date: _____



Brian

Using the Standard Algorithm to Divide Decimals by Whole Numbers

- 1 If Brian wants to split 7 pounds of flour equally into 20 containers, how many pounds of flour will be in each container? Explain your thinking.

Did you explain your thinking?



- 2 Continue the pattern.

32, 40, 48, , ,

The numbers in this pattern are multiples of .

- 3 Divide. $7 \overline{)547.96}$ $4 \overline{)347.8}$

- 4 After dinner, 4 friends decide to split their restaurant bill of \$127.24 equally. How much should each friend pay? Show your work.

Did you show your work?



Name: _____

Date: _____



Solving Decimal Division Word Problems Using Estimation

- ① Use the standard algorithm to solve.

$$12 \overline{) 37.2}$$

- ② Use the standard algorithm to solve.

$$\begin{array}{r} 48 \\ \times 37 \\ \hline \end{array}$$

- ③ Find the quotient. $5.4 \div 6 =$

- ④ The school carnival is selling popcorn. Donner paid \$31.80 for 12 bags of popcorn to share with his class. If each bag of popcorn costs the same amount of money, what is the price of 1 bag of popcorn? Show your thinking.

Did you show your thinking?



- ⑤ Aleki and Donner found a metronome at the music shop for \$38.92. They decided to share the metronome and to split the cost equally. How much did they each pay for the metronome?

Name: _____

Date: _____



Louis

Solving Problems with Decimal Multiplication and Division

- 1 Use the model to multiply. Show your thinking.

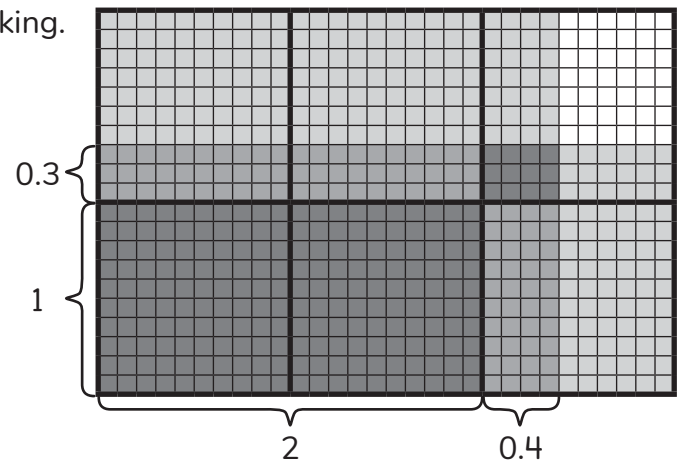

Did you show your thinking?



- 2 Louis uses 3 kinds of juice to make some punch for guests at a barbecue. He mixes together 1.8 liters of each type of juice to make the punch. Then, he pours the punch equally into 12 glasses. How much punch does Louis pour into each glass? Show your work.

Did you show your work?



- 3 A science teacher bought 3 chemistry sets and 6 physics sets for class. She paid \$52.80 for each chemistry set and \$34.29 for each physics set. How much money did she spend in total? Show your thinking.

Did you show your thinking?



Topic 8

Expanding Financial Literacy

Recommended ST Math Objectives:

Comparing with Decimals

Multiplying with Decimals

Decimal Place Value

Name: _____

Date: _____

Solving Problems Involving Sales and Property Taxes

① Solve. $2\frac{3}{4} + 4\frac{1}{3} =$ $7\frac{1}{6} - 2\frac{1}{2} =$

② Use $<$, $>$, or $=$ to compare.

3.7 $3\frac{7}{100}$ 2.46 $2\frac{1}{2}$ $10\frac{1}{4}$ 10.25
 $5\frac{7}{12}$ $5\frac{4}{10}$ $4\frac{6}{7}$ $4\frac{6}{8}$ $7\frac{2}{3}$ $7\frac{8}{11}$

③ Circle ALL of the words that correctly complete the sentences.

a) People pay property tax each year when they own _____.

homes farms cars land furniture

b) The government uses taxes from citizens to pay for running _____.

schools restaurants libraries health care

hotels water treatment

③ A baseball coach wants to buy 5 baseballs that are each \$6.49 and 2 bats that are each \$92.54.

a) What is the total cost of all the items?

b) The coach has \$220. Does she have enough money to buy all of the items?
Explain your thinking.

Did you explain
your thinking?



Name: _____

Date: _____

Solving Problems Involving Gross and Net Income

1 a) Draw a right triangle.

2 Based on the data below, how many students practiced for less than 100 minutes?

**Number of Minutes
Students Read Last Week**

Stem	Leaf
7	0 4 5 5 7 9
8	2 5 7
9	6
10	0 0 0 3 5 8
11	1 3 4 6 6

b) Draw an obtuse triangle.

7|4 means 74 minutes.

3 Match each term to its definition.

gross income

income tax

net income

payroll tax

the amount of money an employee actually receives from a paycheck after deductions are subtracted from gross income

a tax paid on income, often deducted from an employee's paycheck

a tax paid on income and used to fund a specific program such as Medicare or Social Security, often deducted from an employee's paycheck

the total income an employee earns before taxes and other deductions are subtracted

4 An office worker has a monthly net income of \$4,080. Each month, she has deductions of \$490 for income tax, \$270 for payroll tax, and \$340 for health insurance. What is her monthly gross income? Show your work.

Did you show your work?



Name: _____

Date: _____

Solving Real-World Problems with Decimal Operations

- 1 Draw a quadrilateral that has 1 pair of parallel lines and exactly 2 right angles. Then, give the name of the shape.

- 2 A locker is 5'4" tall. How tall is the locker in inches?

1 foot = 12 inches

- 3 a) The fifth graders are holding a movie night fundraiser. Calculate the cost of each of their expenses and then calculate their total expenses.

Item	Cost	Number	Expense
jars of popcorn	\$3.27	5	
packs of popcorn boxes	\$8.79	16	
printed flyers	\$0.15	240	
packs of glow sticks	\$17.73	8	
Total			

- b) The fundraiser gets \$1,290 from ticket sales. What is the profit from the fundraiser? Show your work.

Did you show your work?



- c) The profit is shared equally between 3 fifth-grade classes to help them go on a field trip. How much does each fifth grade class get?

Name: _____

Date: _____

Introducing and Balancing a Budget

- 1 Circle the division expression that will have a quotient that is greater than 6.

$$\frac{1}{4} \div 6$$

$$6 \div \frac{1}{4}$$

- 2 Solve. $\frac{1}{4} \div 6 =$

$$6 \div \frac{1}{4} =$$

- 3 A student wants to make a balanced budget. Calculate his total income. Then, use the total income to determine how much he can put into savings to make a balanced budget.

Next Month's Budget			
Income		Expenses	
allowance	\$10	games	\$20
babysitting	\$40	snacks	\$25
helping Mr. Martinez	\$20	donation to school fundraiser	\$10
		savings	
Total Income		Total Expenses	

- 4 An artist wants to buy 4 brushes that are each \$5.59 and 3 painting canvases that are each \$17.18.
- a) What is the total cost of all the items?
- b) The artist brought \$75 to the store. Will he have enough money to buy all the items? Explain your thinking.

Did you explain your thinking?



Name: _____

Date: _____

Comparing Advantages and Disadvantages of Payment Methods

- 1 A rectangular prism has a volume of 48 cubic inches and a height of 8 inches. What could be the dimensions of the rectangular prism's base?

- 2 Round 29.095 to the nearest hundredth.

- 3 Match each type of payment to its description which outline its advantages and disadvantages.

check

does not require technology, but cannot be replaced if lost or stolen

cash

card that usually does not have any fees, but can only be used to spend up to the total amount saved in a bank account

electronic payment

card that can give cash back or rewards, but borrowed money has high interest unless the full balance is paid each month

credit card

payment happens immediately, but requires technology

debit card

usually has no fees, but the person who receives this must deposit it into their own bank

- 4 A delivery driver needs to make an emergency car repair that costs \$1,250. She has \$1,400 in the bank. What payment type should she use to pay for the repairs? Explain your thinking.

Name: _____

Date: _____

Solving Budget Problems When Expenses Exceed Income

- ① When multiplying $4 \times \frac{2}{3}$, the product will be greater than
less than 4 and greater than
less than $\frac{2}{3}$.

② Solve. $4 \times \frac{1}{3} =$ $4 \times \frac{2}{3} =$

- ③ a) Mr. Liu calculates his total income and expenses in this budget.

Next Month's Budget			
Income		Expenses	
customer service net income	\$3,250	rent	\$1,850
photography net income	\$250	groceries	\$475
piano lessons net income	\$475	utilities	\$625
gift from Mom	\$200	car payment	\$325
		savings	\$500
		activities	\$350
		restaurants	\$200
Total		Total	

- b) Give 3 specific examples of how Mr. Liu could change his budget to make it balanced.
- c) Could Mr. Liu balance his budget by paying less rent for his apartment each month? Use the terms *fixed expense* and *variable expense* to explain why or why not.

Topic 9

Organizing Two-Dimensional Space

Recommended ST Math Objectives:

The Coordinate Plane
Shapes and Properties
Angles

Name: _____

Date: _____



Sorting and Classifying Triangles by Side Lengths and Angles

1

Solve.

$$\begin{array}{r} 49 \\ \times 35 \\ \hline \end{array}$$

2

Draw a shape that has at least 1 acute angle and 1 obtuse angle.

3

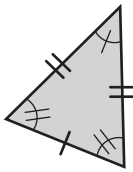

a) What is the same about these triangles?

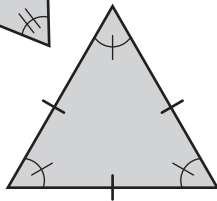

b) What is different about these triangles?

4

Louis says that this triangle is an acute triangle because it has 2 acute angles. Do you agree with the way that Louis has named the triangle? Explain your thinking.

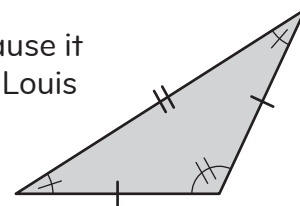

Did you explain your thinking?

5

A school held its annual walkathon. There are 567 students in the school. If every student raised \$35, what is the total amount of money raised?

Name: _____

Date: _____



Donner

Classifying Triangles into Multiple Categories and Subcategories

- 1 Round 284.487 to the nearest whole number.

 - 2 Draw 3 different shapes with at least 1 right angle.

 - 3 Is an equilateral triangle also an isosceles triangle? Explain your thinking.

 - 4 What is the name of a triangle that has 2 sides that are equal in length and 1 obtuse angle?
- Did you explain your thinking?
- 5 Donner takes a 0.45 mile walk around the block every day. How far does Donner walk in a 7-day week? How far does Donner walk in a 30-day month?

Name: _____

Date: _____



Classifying Quadrilaterals into Multiple Categories and Subcategories

- 1 Mateo has 6 containers of paint left over from an art project. If each container has $\frac{3}{4}$ cup of paint, how many cups of paint does Mateo have in all?

- 2 Circle the shapes that appear to have at least 1 acute angle.

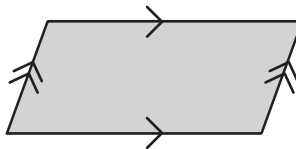
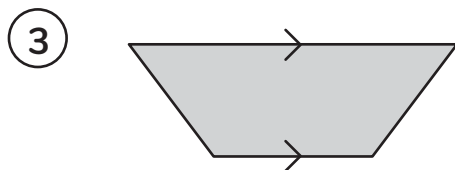
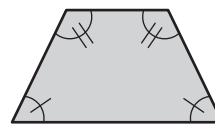
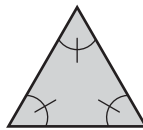

a) What attribute is the same about these 2 shapes?

b) What attribute is different about these 2 shapes?

- 4 I am a quadrilateral with 2 sets of parallel sides. What shape might I be?

- 5 The art teacher ordered supplies for the school art program. He ordered 50.5 ounces of glue. He used all of the glue to fill 5 jars. If he filled each jar with the same amount of glue, how much glue did he put in each jar?

Name: _____

Date: _____

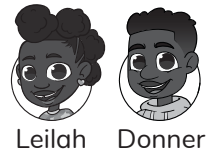

Classifying Quadrilaterals in a Hierarchy

1 Solve. $\frac{1}{8} \div 4 =$

2 Leilah has 21 yards of fabric. How many feet of fabric does Leilah have? Explain your thinking.

3 Draw a  in the correct category.

Quadrilaterals

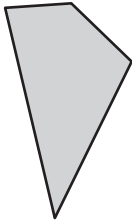

Trapezoids

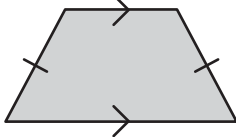

Parallelograms

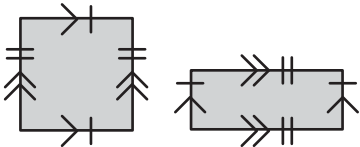

4 Is a square always a parallelogram? Explain your thinking.

Did you explain your thinking?

5 Donner made 2 pounds of his famous trail mix. He sold $\frac{1}{8}$ of the trail mix to his friends. How many pounds of trail mix did Donner sell? Explain your thinking.

Name: _____

Date: _____

Evaluating Claims About Polygons

1 A carpenter has a monthly net income of \$3,700. Each month, she has deductions of \$410 for income tax, \$240 for payroll tax, and \$360 for health insurance. What is her monthly gross income?

2 The volume of a rectangular prism is 56 cubic centimeters. Its height is 7 centimeters. What could be the dimensions of the prism's base?

3 Draw lines to show where each shape belongs in the diagram.

square right triangle trapezoid rectangle isosceles triangle

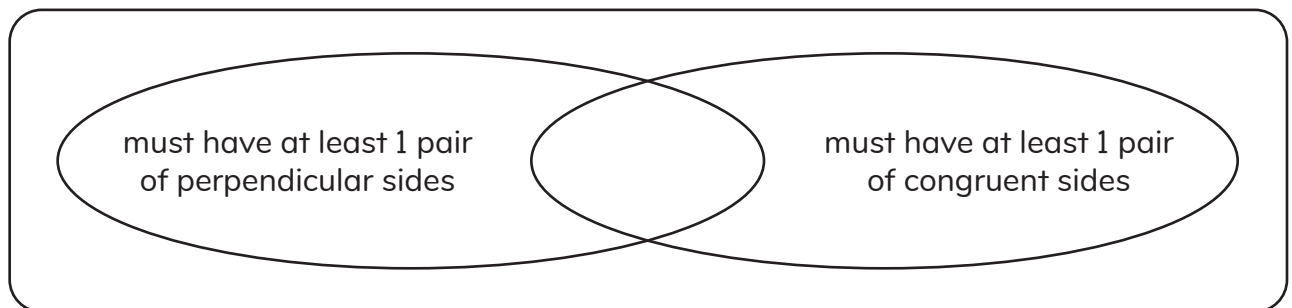

4 Circle the correct word to show when each statement is true.

a) An equilateral triangle is an acute triangle. **always** **sometimes** **never**

b) A parallelogram is a rhombus. **always** **sometimes** **never**

c) An equilateral triangle is an isosceles triangle. **always** **sometimes** **never**

d) A circle is a polygon. **always** **sometimes** **never**

e) A rectangle is a trapezoid. **always** **sometimes** **never**

Name: _____

Date: _____

Exploring the First Quadrant in the Coordinate Plane

- ① Draw a quadrilateral that has at least 1 acute angle.

- ② Draw 2 lines of symmetry.



- ③ The ordered pair for the triangle is (1, 2).
What is the ordered pair for the heart?

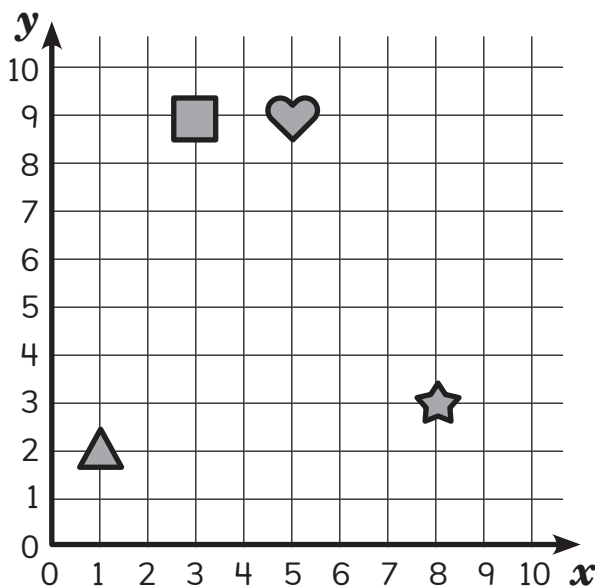

- ④ The dot is located at (9, 8).
Draw another dot at (4, 7).

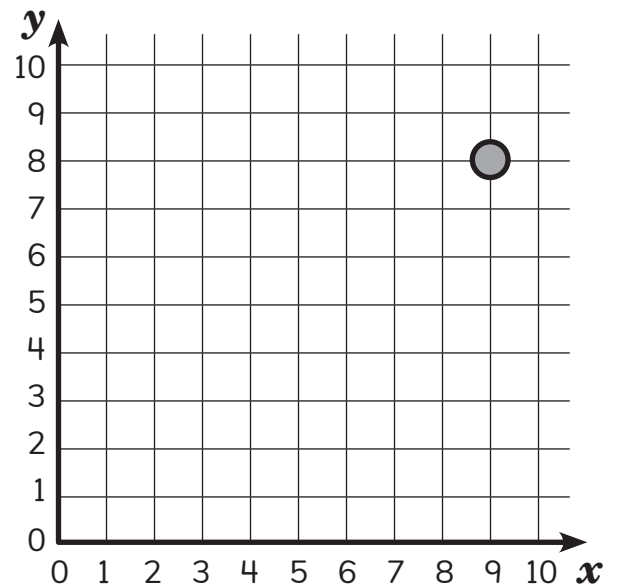

- ⑤ A model train has 15 train cars that are all the same length. The train is 36 inches long.
What is the length of each train car?

Name: _____

Date: _____



Representing Polygons on the Coordinate Plane

- 1 Solve.

$$3,038 \div 62 = \boxed{}$$

- 2 Hannah grew a pumpkin that weighed 15 pounds for the state fair contest. The winning pumpkin weighed 12 times as much as Hannah's pumpkin. How many pounds did the winning pumpkin weigh?

- 3 a) Plot the following points on the coordinate plane:
(2, 2), (6, 2), (4, 7), (8, 7)
- b) What is the name of the quadrilateral you drew on the coordinate plane?

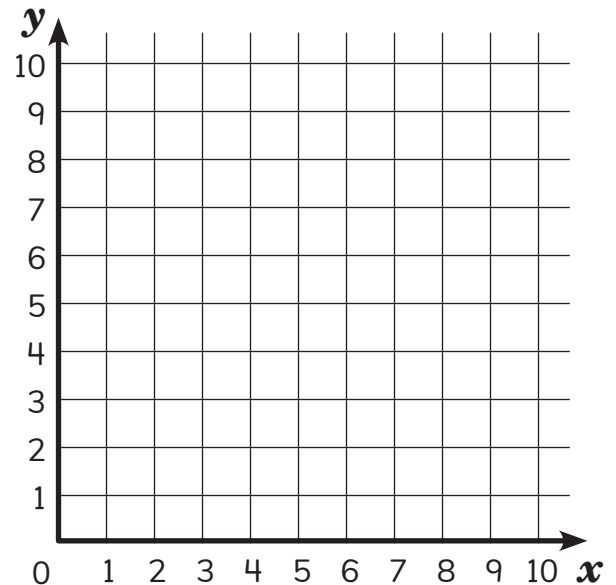

- 4 A fish tank at the aquarium is in the shape of a rectangular prism. Its volume is 320 cubic feet. The length of the fish tank is 10 feet and its width is 8 feet. What is the height of the fish tank?

Name: _____

Date: _____

Plotting Tables of Values on the Coordinate Plane

1

A board is 4'8" long.
How long is the board in inches?

1 foot = 12 inches

2

Simplify.

$$9(6 + 2) - (4 + 8 \div 2)$$

3

a) Graph the points.
(6, 3.5), (2, 1.5), (6, 7), (2, 5)

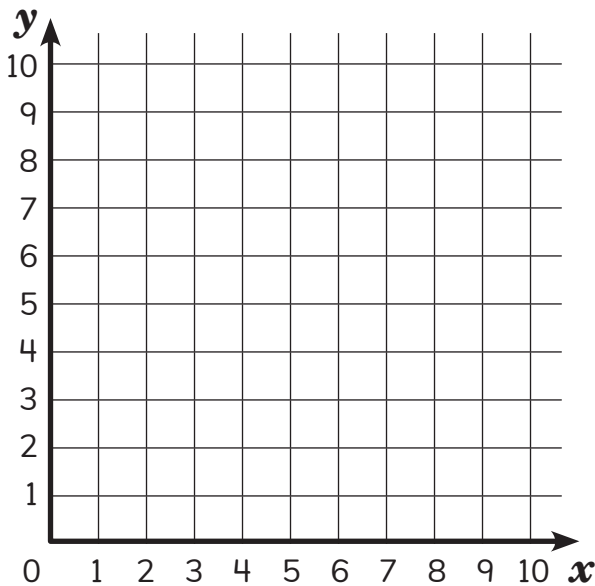

b) If the points are connected to form a polygon, what does the shape appear to be?

4

Graph the points shown in the table.

x	2	$3\frac{1}{2}$	1	$4\frac{1}{4}$
y	$3\frac{1}{2}$	$4\frac{1}{2}$	$\frac{3}{4}$	$1\frac{1}{2}$

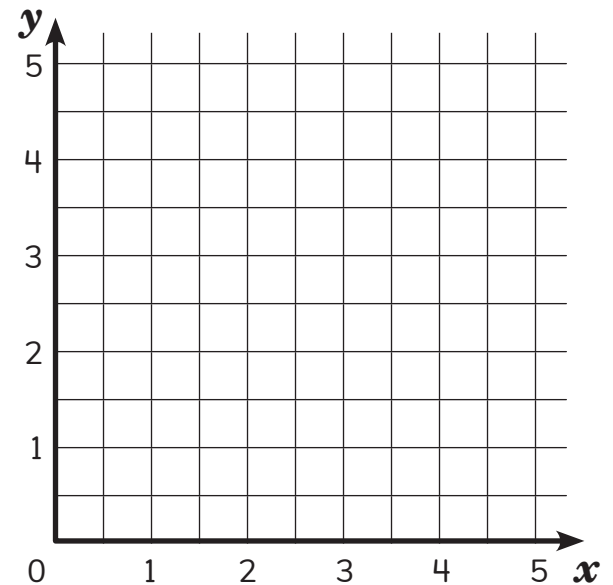

5

Is this statement always, sometimes, or never true?

Parallelograms have 4 right angles.

Explain your thinking with examples or counterexamples.

Did you explain your thinking?



Topic 10

Exploring Relationships in Data

Recommended ST Math Objectives:

Using Data and Graphs
Patterns and Relationships
Converting Measurements

Name: _____

Date: _____



Aleki

Exploring Variables

1 Find the value of the expression. $8 + [(9 - 4) \times (2 + 9)] - 2$

2 Circle the prime numbers. 25 80 31 73 68 2 9

3 a) Complete the table.

+ 5 =

8	
0	
	6
6	
	14
5	

b) Graph the values from the table.

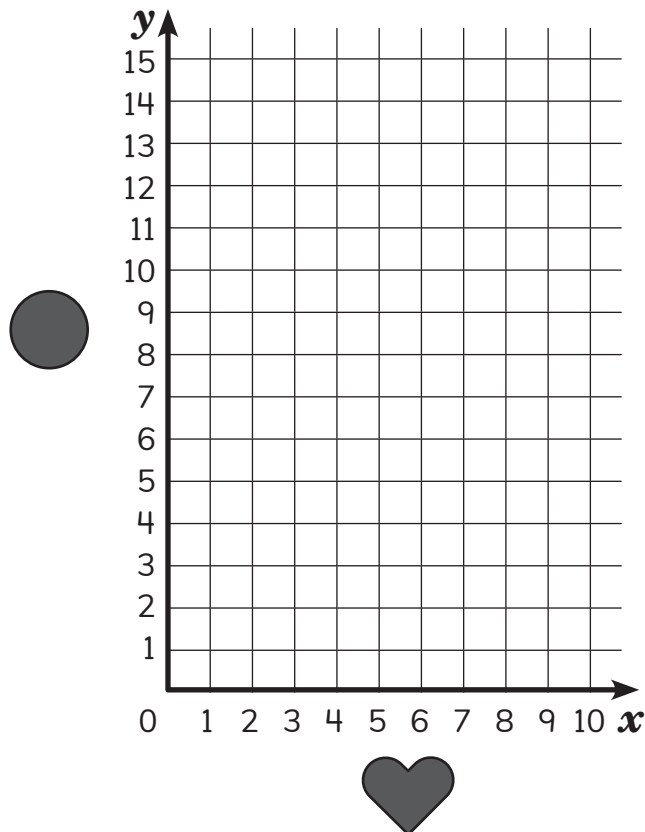

4 Tickets for Aleki's band concert were sold for \$12 each. A total of \$2,208 was collected from these ticket sales. How many tickets were sold for the concert? Show your thinking.



Name: _____

Date: _____



Anjali

Graphing Additive Relationships with Input–Output Tables

- 1 This model shows 1 whole. Shade the model to represent $0.9 \times 0.6 = 0.54$.

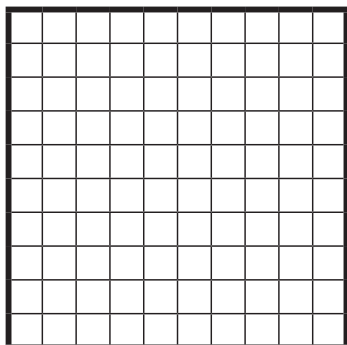

- 2 Circle the word form of the expression.
 $(5 \times 10) + (4 \times 1) + (7 \times 0.1) + (9 \times 0.001)$

fifty-four and seventy-nine hundredths

fifty-four and seven hundred nine thousandths

fifty-four and seven hundred nine

fifty-four and seventy-nine thousandths

- 3 a) Complete the table.

$$y = x + 1.5$$

x	y
0	
1	
2	
3	

- b) Graph the values from the table.

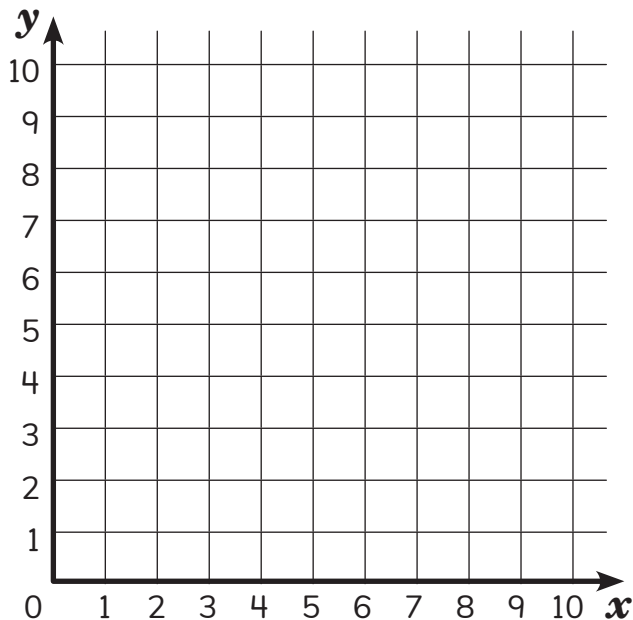

- 4 While cleaning her room, Anjali found 10 cents on her desk, 97 cents under her bed, and 3 dollars and 5 cents in her closet. What was the total amount of money Anjali found? Show your thinking.

Did you show your thinking?



Name: _____

Date: _____



Brian

Graphing Multiplicative Relationships with Input–Output Tables

- 1 Circle the rectangles that have a volume of 24 cubic centimeters.

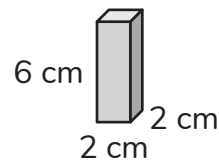
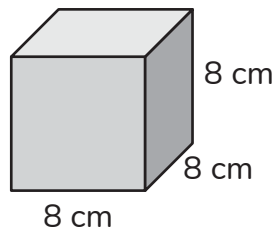
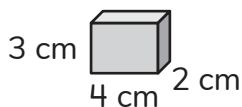

- 2 Find the quotient. $\frac{1}{3} \div 5$

- 3 a) Complete the table.

$$4x = y$$

Input x	Output y
0	
$\frac{1}{2}$	
1	
$\frac{3}{2}$	

- b) Graph the values from the table.

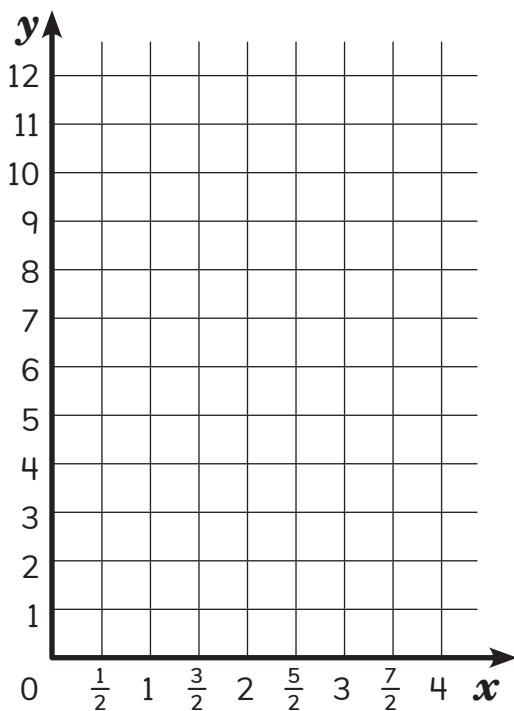

- 4 Brian baked 8.5 batches of muffins for his school. Each batch of muffins used 1.5 cups of flour. How many total cups of flour did Brian use? Explain your thinking.

Did you explain your thinking?



Name: _____

Date: _____



Mateo

Identifying Independent and Dependent Variables

- 1 Circle all of the names that can be used to describe the shape.

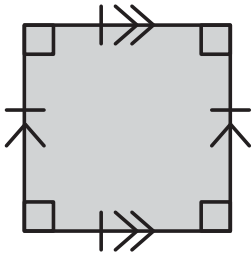

- square
- rectangle
- rhombus
- trapezoid
- parallelogram

- 2 Find the value of the expression.
 $3(26 + 18) + 4(3)$

- 3 Complete the table and graph the points.

I make \$3 for every hour I mow lawns. To figure out my earnings, I am using the equation $m = 3t$, where t is the time in hours and m is the amount of money in dollars.

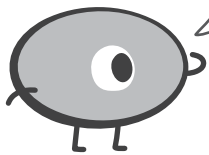

Money Earned Mowing Lawns

Time Worked, t (hours)	Money Earned, m (\$)
1	
2	
	9
	15

Money Earned Mowing Lawns vs. Time

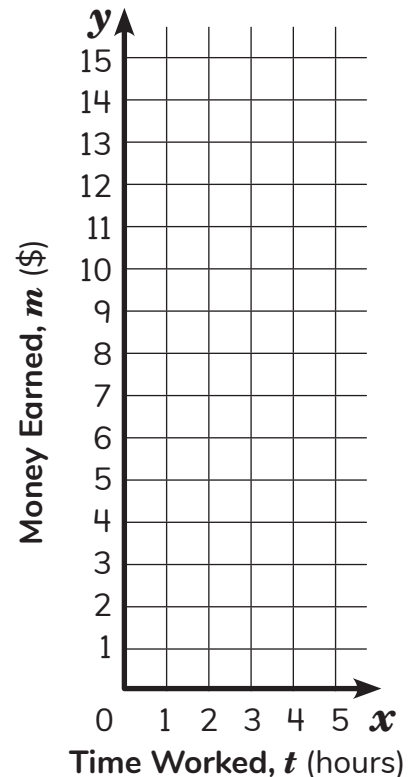

- 5 Mateo used a full 2-liter bottle of dog shampoo to fill 2 containers.
- He put 0.485 liters of shampoo in the first container.
 - He put 0.65 liters of shampoo in the second container.

How many liters of shampoo remain in the 2-liter bottle? Show your thinking.

Did you show your thinking?



Name: _____

Date: _____

Identifying Additive and Multiplicative Relationships in Scatterplots

- 1 Find the length of the rectangle.



$$P = 320 \text{ inches}$$

- 2 Solve.

$$\frac{16}{25} - \frac{22}{50} = \boxed{8}$$

- 3 Plot the data in the scatterplot.

Number of Students, s	2	3	6	8
Number of Goodie Bags, g	4	5	8	10

What type of relationship does this data show?
Circle one.

additive relationship

multiplicative relationship

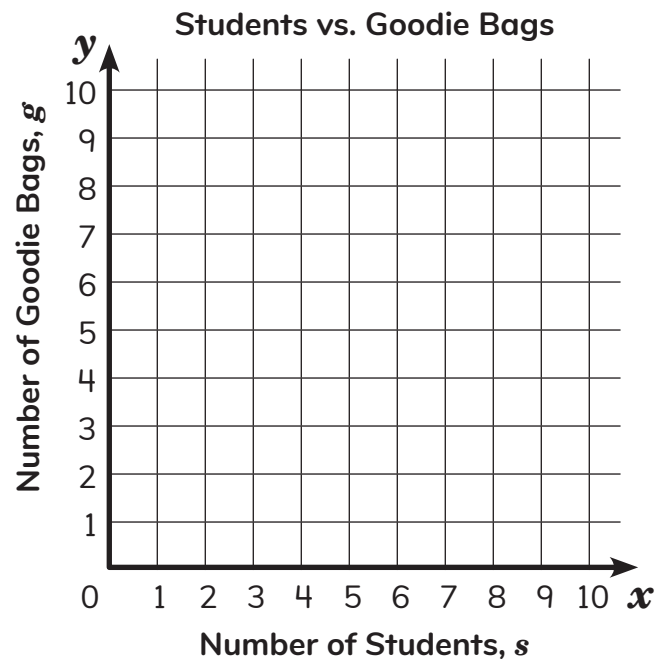

- 4 There are 7 glasses of lemonade. Each glass has 0.4 liters of lemonade. How many milliliters of lemonade are in all 7 glasses combined? Show your thinking.

1 liter (L) = 1,000 milliliters (mL)

Did you show your thinking?

Name: _____

Date: _____



Graphing Relationships from Written Descriptions

Vivi

1 Solve. $46.8 - 7.08 =$

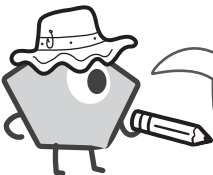
2  I bought a new hat!
Circle the tax that I paid as a part of the total cost of the hat.
income tax sales tax payroll tax property tax

- 3 During a card tournament, 3 rounds are played every hour.
- a) Create a graph to show the total number of rounds that are played each hour. Label the title and each axis on the graph.
- b) Circle the type of relationship shown in the data on the graph.
- additive relationship**
- multiplicative relationship**

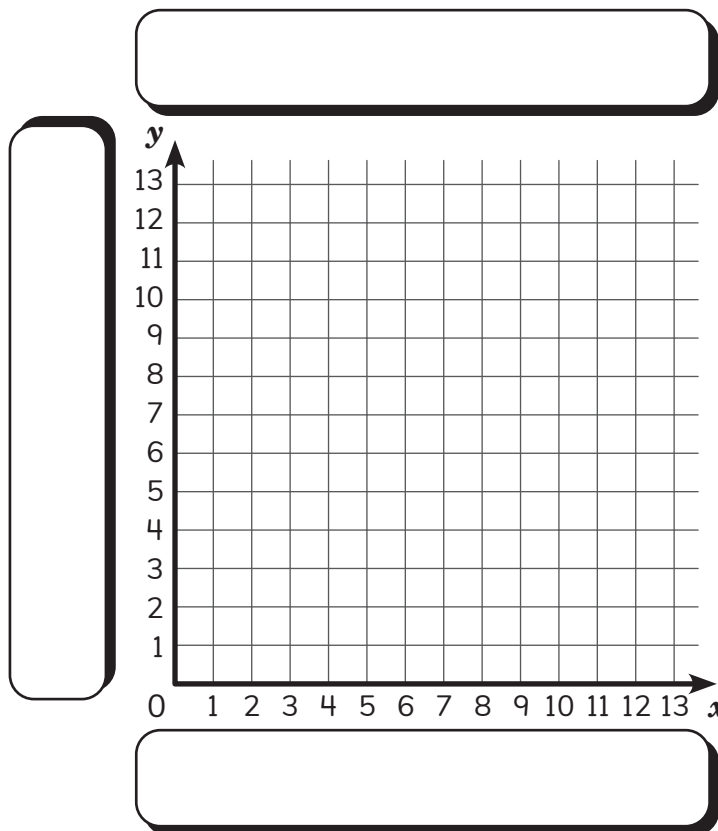

4 Vivi made 35 necklaces. She sold $\frac{4}{5}$ of the necklaces at the market. How many necklaces did Vivi sell? Show your thinking with an equation.

Did you show your thinking with an equation?

Name: _____

Date: _____

Analyzing Correlations in Real-World Scatterplots

- ① Use the standard algorithm to solve.

$$\begin{array}{r} 127 \\ \times 53 \\ \hline \end{array}$$

- ② Use the model to represent the quotient of $\frac{1}{3} \div 4$.

- ③ Label the title and each axis.
Graph the data from the table.

Height of Reader, h (feet)	Number of Books Read, b
3.5	6
4	3
3.5	5
4.5	7
4	6
4.5	5
3.5	2
4	4

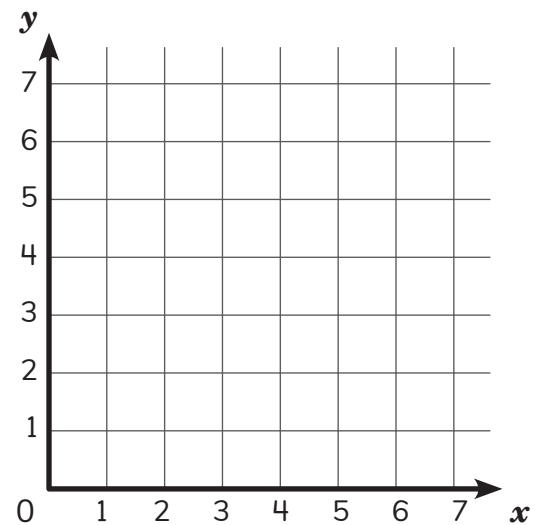

- ④ There are 3 pies. Each pie is cut into equal slices. Each slice is $\frac{1}{6}$ of a pie.
How many slices are there? Show your thinking with an equation.

Did you show your thinking with an equation?



Name: _____

Date: _____

Graphing Data in Scatterplots with Broken Axes

- 1 Find the area of the figure.

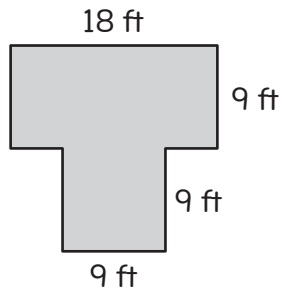

$$A = \boxed{}$$

- 2 Use the standard algorithm to solve.

$$40 \overline{)1,840}$$

- 3 a) Graph the data from the table.

Number of Critters at the Picnic, c	Number of Birds Seen, b
20	15
25	10
30	35
35	40
40	15
45	20

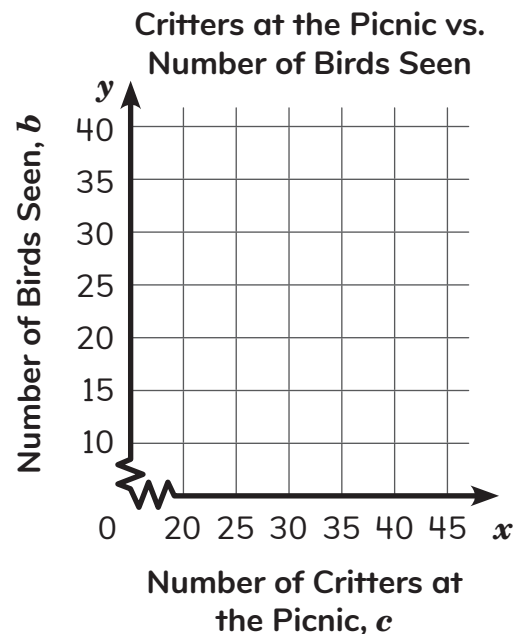

- b) Does the graph show a correlation between variables or no correlation between variables? Explain your thinking.

Did you explain your thinking?



- 4 The critters used a total of 2.4 pounds of ground beef to make 8 equal-sized hamburgers. How much ground beef was used for each hamburger?

Name: _____

Date: _____

Analyzing Data in Frequency Tables and Bar Graphs

1 Create a graph to represent the ordered pairs.

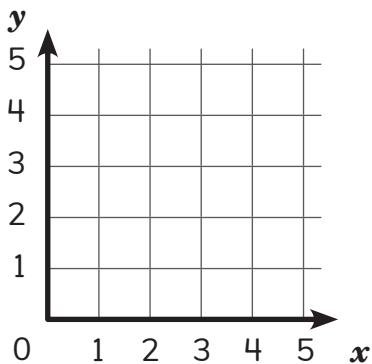
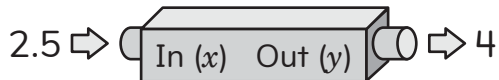
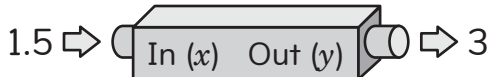
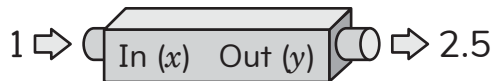
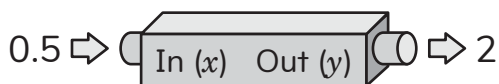

2 Find the value of 1.5×5.3 .

3 Use the data to complete the frequency table. Then, use your frequency table to create a bar graph.



5, 13, 7, 2, 11, 27, 40, 24,
13, 31, 9, 18, 0, 6, 21, 8,
14, 10, 33, 19, 12, 36, 18,
15, 3, 17, 35, 28, 10

Ages (years)	Number of Visitors
0-5	
6-10	
11-15	
16-20	
21-25	
26-30	
31-35	
36-40	

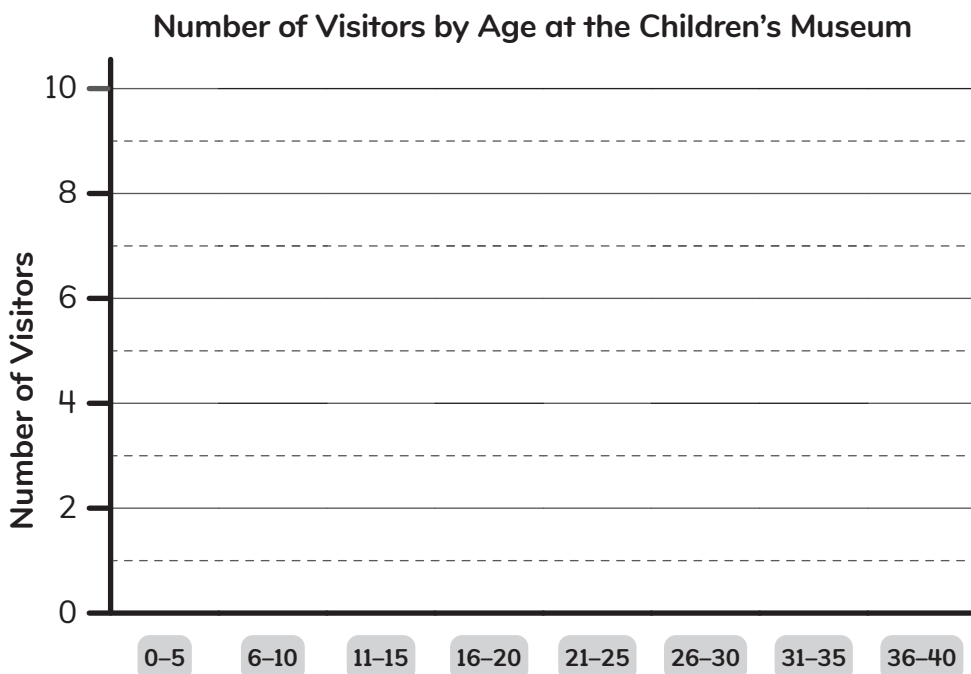

a) What is the difference between the number of visitors who were younger than 16 and the number of visitors who were 16 and older?

b) How many visitors were younger than 21 years old?

Name: _____

Date: _____

Analyzing Data in Stem-and-Leaf Plots and Dot Plots

- ① Solve.

$$\frac{2}{5} + \frac{3}{12} + \frac{1}{20} = \left. \begin{array}{c} \square \\ \square \end{array} \right\}$$

- ② Circle the expression with the greatest value.

$$6 \times (2 + 5) + 8$$

$$6 \times 2 + 5 + 8$$

$$6 \times (2 + 5 + 8)$$

- ③ Use the data in the stem-and-leaf plot to create a dot plot.

**Timed Practice Runs
of Skateboarders**

Stem	Leaf
30	0 0 5
31	0 0 0 5 5 5 5
32	0 5 5 5 5
33	0 0 0 0 0

30|5 means 30.5 seconds.

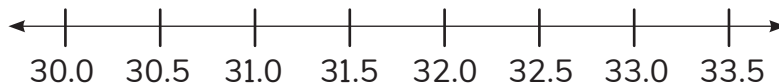

Skateboarders' Practice Run Times

- a) What is the difference between the shortest practice run time and the longest practice run time?
- b) What fraction of the practice runs lasted more than 30 seconds?

- ④ A rectangular sign is 4.33 feet tall and 6.5 feet wide. What is the perimeter of the sign in feet? Show your thinking.

Did you show your thinking?



Name: _____

Date: _____

Analyzing Data in Multiple Representations

- 1 Circle the name of the shape that is missing from the diagram.

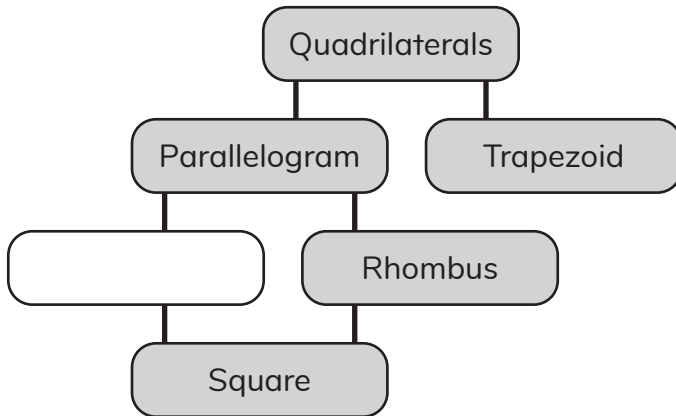

Hexagon
Polygon

Rectangle
Triangle

- 2 Fill in the missing numbers to create an expression to represent the model.

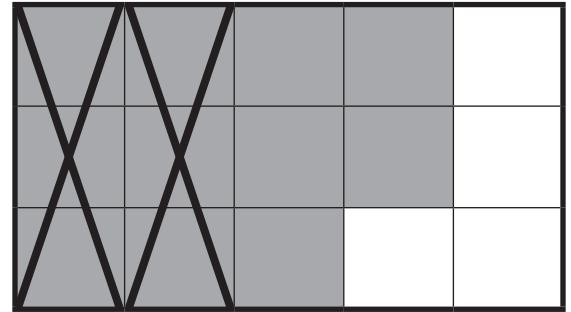

$$\begin{array}{r} \square \\ 15 \end{array} - \begin{array}{r} 2 \\ \square \end{array}$$

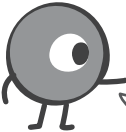
- 3  Use the data to complete the stem-and-leaf plot.

Number of Items Donated By Class
for a Year-End Charity Drive

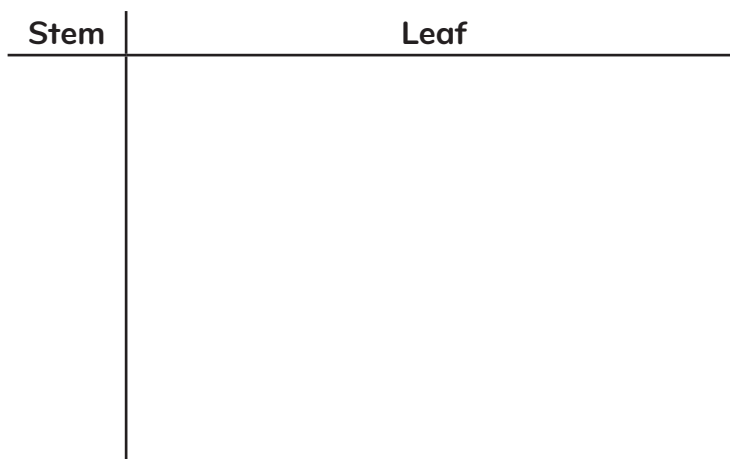

3|4 means 34 items.

25, 33, 15, 34, 10, 21, 14, 42, 10,
26, 19, 18, 40, 15, 22, 34, 13, 16,
19, 36, 28, 16, 13, 17, 48, 37

- a) What is the difference between the greatest and least number of items donated?

- b) How many classes donated more than 20 items?



ST Math
Texas

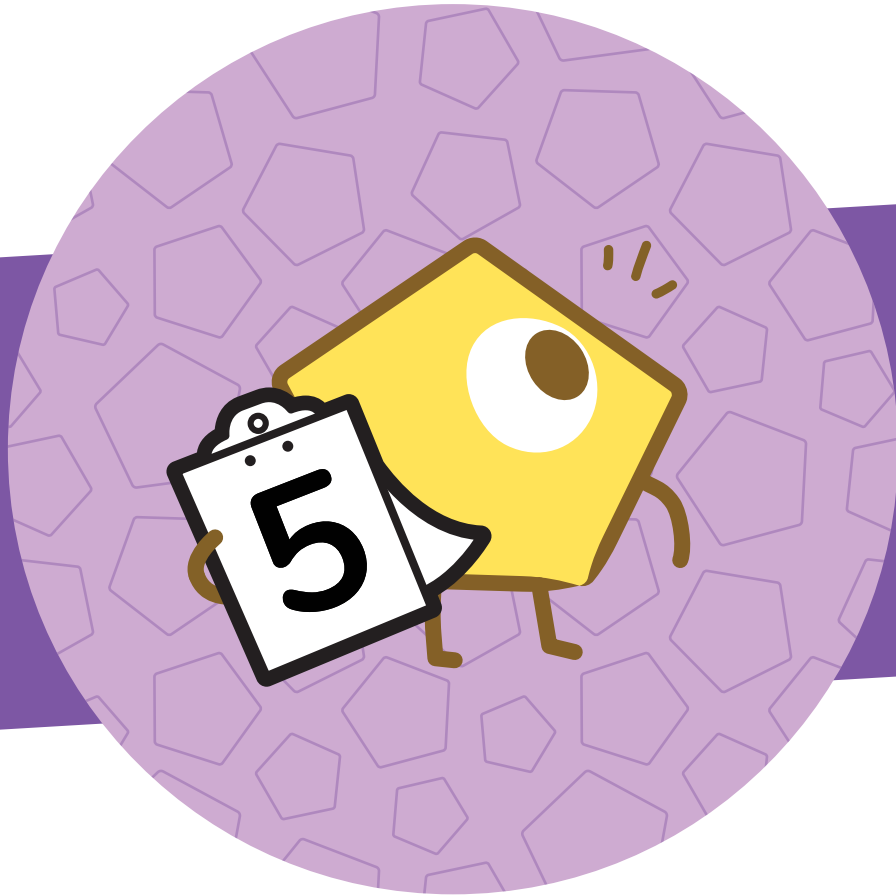

MIND
EDUCATION®

© 2026 MIND Education®. All Rights Reserved.