



ST Math
Texas

Grade 4

ST Math Practice Book

Whose book is this?

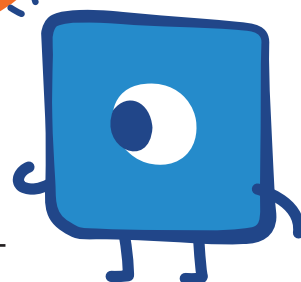

Building Mathematical Progressions Within and Across Grade Levels

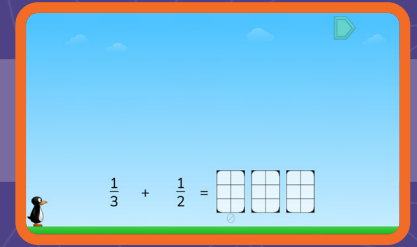
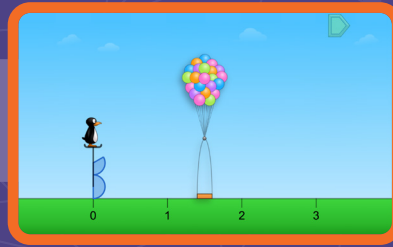
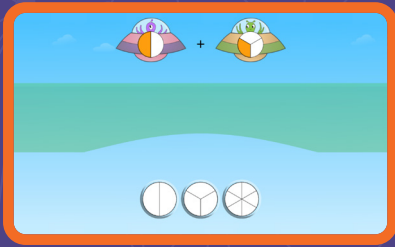

Multiple models for every concept within a grade level

Visual-First Learning That Makes Math Click

ST Math Texas is built around a patented visual-first approach that helps students see and understand math. Interactive visuals activate students' spatial-temporal reasoning, building deep understanding even before introducing formal language or procedures.

These scaffolded models support problem-solving, strategy sharing, and big-picture thinking—making math feel coherent and connected across and within grade levels.

To deepen learning, lessons use multiple representations—visuals, numbers, words, and symbols—helping students form a rich network of ideas they can apply to new problems.

With **ST Math Texas** students go beyond memorization. They develop a connected understanding of math concepts, apply their learning flexibly, and build lasting confidence.

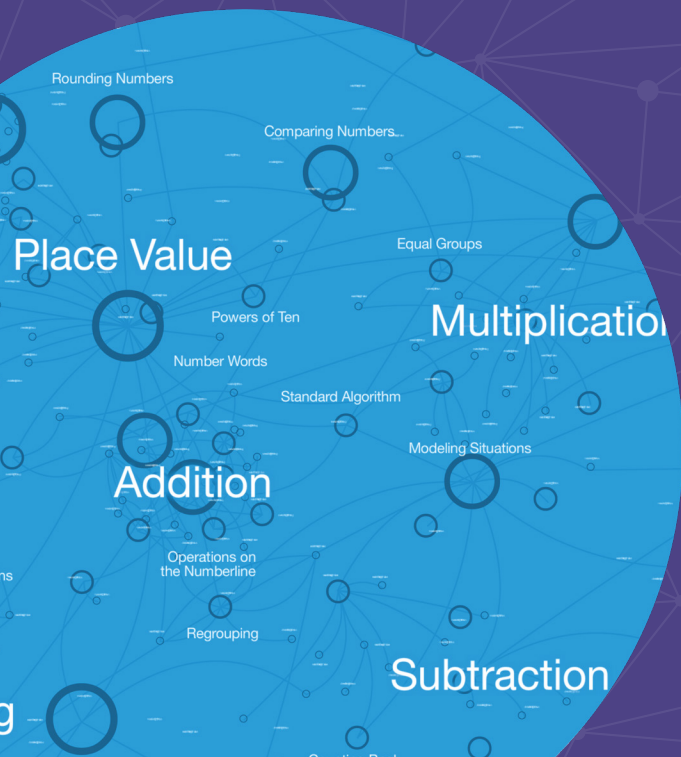

Expressions
Grade 5

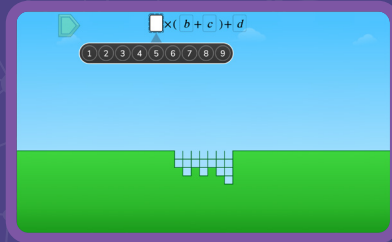

Fractions
Grade 4

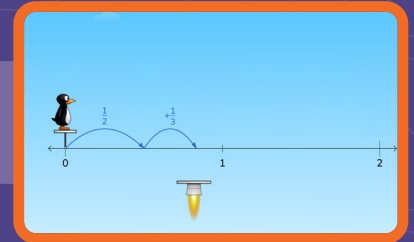
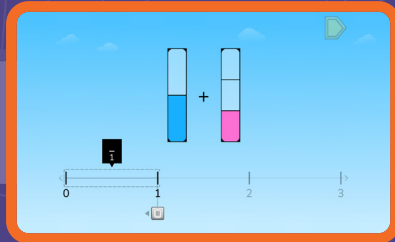

Multiplication
Grade 3

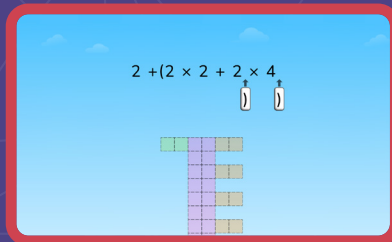

Subtraction
Grade 2

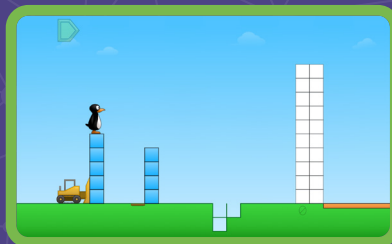

Addition
Grade 1

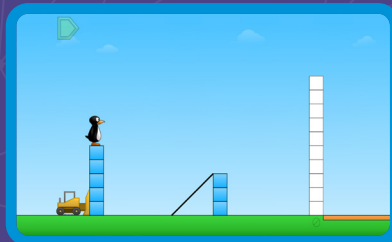

Counting
Grade K

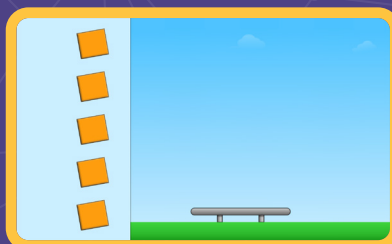

Connected visual
models build in
complexity across
grade levels

©2026 by MIND Education. All rights reserved.

No part of this work may be used or reproduced in any manner whatsoever without the written permission of MIND Education.

MIND Research Institute
5281 California Avenue, Suite 300
Irvine, CA 92617

How to Use This Document

This practice book is a standards-based, year long practice book companion to ST Math Texas.

To use this book in conjunction with ST Math Texas, find the digital games and objectives tied to each Topic. The hyperlinks will take you to the page that allows you to assign the ST Math Texas Objectives that go along with these practice pages.

These pages are designed to be printed and solved with paper and pencil. They come with spiral review, related topics and problems, and world problems that connect to the world around us.

Our help site offers further ties between ST Math, this practice book, and your school or district's curriculum.

Content Overview

Students enter grade 4 with an existing schema of multiplication as the mathematics of equal groups. They extend that schema in **Topic 1 (Exploring Multiplicative Relationships)** to generate a more robust concept of multiplicative relationships as they explore factors, multiples, and input-output tables. They begin to explore division situations with remainders and interpret remainders in context. **Topic 2 (Discovering Multiplicative Comparison)** extends students' multiplication schemas further to include situations involving multiplicative comparison. Students develop their language skills related to these situations, and apply understanding of multiplicative relationships to convert between customary topics of measurement.

In **Topic 3 (Extending Place Value and Adding and Subtracting Efficiently)**, students generalize place value reasoning, making use of periodicity to work with numbers up to one billion. They describe place value relationships as multiplicative comparisons and use place value reasoning to compare, add, and subtract multidigit numbers. In **Topic 4 (Extending Multiplication to Multidigit Whole Numbers)** and **Topic 5 (Building Division Strategies)**, students connect place value reasoning to their understanding of factors and multiples to generalize multiplication and division strategies, and then extend those strategies in **Topic 6 (Extending Division Strategies)**.

The next pair of topics focus on fractions. Students begin **Topic 7 (Extending Addition and Subtraction to Fractions)** by extending their fraction schema to include numbers greater than 1, and to express them in different but equivalent ways including fractions, whole numbers, and mixed numbers. They continue to think of Topic fractions as they do other topics, and build understanding that fractions can be added or subtracted when they are expressed with common Topic fractions. In **Topic 8 (Exploring Fraction Thinking and Discovering Decimals)** extend their understanding of equivalence to represent numbers as equivalent fractions and as decimals and explore ways to generate these equivalent forms and compare numbers.

In **Topic 9 (Extending Financial Literacy)**, students use money contexts to support understanding of addition and subtraction of decimals. They explore thinking of decimals as fractions and to extend whole number place value reasoning to decimals, and see that both of these are legitimate ways to think about adding and subtracting decimals. Students have the opportunity to further practice adding and subtracting decimals as they learn about income, expenses, saving, and borrowing.

Students examine two-dimensional shapes and the relationships among their parts in **Topic 10 (Exploring Shapes, Lines, and Angles)** as they extend their classification system. **Topic 11 (Making**

Connections with Time and Data) offers students the opportunity to consolidate much of their learning as they problem solve with fractions, angles, multiples, and data representations in real-world situations.

Topic 1: Exploring Multiplicative Relationships

ST Math Objectives: Factors and Multiples, Generating Patterns, Multi-Digit Multiplication

TEKS: 4.1.A 4.1.B 4.1.C 4.1.D 4.1.E 4.1.F 4.1.G 4.4.C 4.4.D 4.4.E 4.4.F 4.4.H 4.5.A 4.5.B 4.5.C 4.5.D

ELPS: 2.A 2.B 2.C 2.D 2.E 2.F 3.B 3.H 4.A 4.B 4.C 4.E 4.F

Discovering Factor Pairs.....	7
Exploring Square Numbers.....	8
Finding Dimensions of a Rectangle.....	9
Introducing Multiples.....	10
Representing Patterns with Input–Output Tables.....	11
Exploring Patterns of Sequences.....	12
Representing Multiples Plus Some More.....	13
Using Multiples to Solve Problems.....	14
Exploring Multiplication and Division Relationships.....	15
Dividing with Remainders.....	16
Interpreting Remainders.....	17
Solving Division Word Problems with Remainders.....	18

Topic 2: Discovering Multiplicative Comparison

ST Math Objectives: Multi-Digit Multiplication, Applying Area and Perimeter, Factors and Multiples

TEKS: 4.1.A 4.1.B 4.1.C 4.1.D 4.1.E 4.1.F 4.1.G 4.4.B 4.4.D 4.4.H 4.5.A 4.5.B 4.8.A 4.8.B 4.8.C

ELPS: 1.E 2.A 2.B 2.E 2.F 3.B 3.C 3.E 3.F 3.G 3.H 4.A 4.B 4.C 4.E 4.F

Introducing Multiplicative Comparison.....	20
Using Multiplicative Comparison to Solve Problems.....	21
Representing Multiplicative Comparison.....	22
Exploring Multiplicative Comparison.....	23
Using Multiplicative Comparison to Find Unknowns.....	24
Representing Additive and Multiplicative Input-Output Relationships.....	25
Converting Yards to Feet.....	26
Converting Between Customary Length Measurements.....	27
Solving Problems with Customary Length Conversions.....	28
Converting Between Pounds and Ounces.....	29
Converting Between Customary Units of Liquid Volume.....	30
Converting Units to Solve Problems.....	31
Solving Problems with Mixed Customary Measurement Units.....	32

Topic 3: Extending Place Value and Adding and Subtracting Efficiently

ST Math Objectives: Using Place Value, Addition and Subtraction Algorithm, Rounding Whole Numbers

TEKS: 4.1.A 4.1.B 4.1.C 4.1.D 4.1.E 4.1.F 4.1.G 4.2.A 4.2.B 4.2.C 4.2.D 4.4.A 4.4.B 4.4.G 4.5.A 4.8.A 4.8.B 4.8.C 4.9.A 4.9.B

ELPS: 1.B 1.C 1.D 1.E 1.F 2.B 2.C 2.D 2.E 2.F 3.A 3.C 3.D 3.E 3.F 3.G 3.H 4.A 4.B 4.C 4.D 4.E 4.F

Exploring Multiplication Relationships Between Place Values34	
Exploring Multiplication and Division Relationships Between Place Values.....	35
Representing Large Numbers.....	36
Multiplying and Dividing by 10, 100, and 1,000.....	37
Converting Metric Units.....	38
Estimating and Converting Metric Units of Mass.....	39
Comparing Large Numbers.....	40
Rounding Large Numbers.....	41
Reasoning with Large Numbers to Solve Problems.....	42
Creating Stem-and-Leaf Plots.....	43
Interpreting Data with Stem-and-Leaf Plots.....	44
Adding and Subtracting Large Numbers on an Open Number Line.....	45
Estimating Sums and Differences of Large Numbers.....	46
Modeling and Solving Addition and Subtraction of Large Numbers.....	47
Adding and Subtracting Large Numbers Without Regrouping....	48
Adding Large Numbers with Regrouping.....	49
Subtracting Large Numbers with Regrouping.....	50
Reinforcing the Addition and Subtraction Standard Algorithms... 51	
Solving Multistep Problems Involving Addition and Subtraction of Large Numbers.....	52

Topic 4: Extending Multiplication to Multidigit Whole Numbers

ST Math Objectives: Multi-Digit Multiplication, Factors and Multiples, Generating Patterns

TEKS: 4.1.A 4.1.B 4.1.C 4.1.D 4.1.E 4.1.F 4.1.G 4.2.A 4.4.B 4.4.C 4.4.D 4.4.G 4.4.H 4.5.A 4.5.C 4.5.D 4.8.C

ELPS: 1.C 1.E 2.B 2.C 2.D 2.E 2.F 3.A 3.E 3.F 3.G 3.H 4.A 4.B 4.C 4.E 4.F

Using Place Value and Factors to Represent Large Numbers..	54
Using Place Value Reasoning to Multiply 10, 100, and 1,000....	55
Using Place Value Reasoning to Multiply Multiples of 10.....	56
Exploring Strategies to Multiply Two-Digit Numbers.....	57
Multiplying Two-Digit Numbers with the Distributive Property....	58
Multiplying Two-Digit Numbers with Multiple Strategies.....	59
Multiplying up to Four Digits with Multiple Strategies.....	60
Multiplying up to Four Digits with the Standard Algorithm....	61
Solving Multiplication Word Problems with the Standard Algorithm.....	62
Using Area Models to Multiply Two-Digit by Two-Digit Numbers.....	63
Writing Partial Products to Multiply Two-Digit by Two-Digit Numbers.....	64
Multiplying Two 2-Digit Numbers with the Standard Algorithm..	65
Choosing Strategies to Multiply Two-Digit by Two-Digit Numbers.....	66

Choosing Strategies for Multiplication	67
Deriving Formulas for the Perimeter of Rectangles	68
Finding the Perimeter and Area of Squares	69
Modeling and Solving Multistep Word Problems Involving Multiplication	70
Choosing Strategies to Solve Multistep Word Problems Involving Multiplication	71

Topic 5: Building Division Strategies

ST Math Objectives: Multi-Digit Division, Factors and Multiples, Multi-Step Problems Using 4 Operations

TEKS: 4.1.A 4.1.B 4.1.C 4.1.D 4.1.E 4.1.F 4.1.G 4.2.A 4.4.B 4.4.E 4.4.F 4.4.H 4.5.A 4.5.B 4.5.D

ELPS: 1.C 1.E 2.B 2.C 2.E 2.F 3.E 3.F 3.G 3.H 4.A 4.B 4.C 4.E 4.F

Interpreting Division as Partitive or Quotitive	73
Representing Division with Strip Diagrams	74
Modeling and Solving Division Problems on an Open Number Line	75
Exploring Strategies to Solve Division Problems	76
Modeling and Solving Division Problems with Equal Groups	77
Modeling and Solving Division Problems with Arrays	78
Using Multiples and Place Value to Solve Division Problems	79
Exploring Strategies to Solve Division Word Problems	80
Making Equal Groups to Divide Multidigit Numbers	81
Using an Area Model to Divide Multidigit Numbers	82
Partitioning Area Models in Different Ways to Divide Multidigit Numbers	83
Regrouping by Place Value to Divide Multidigit Numbers	84
Building Area Models to Divide Multidigit Numbers	85
Exploring Written Methods to Divide Multidigit Numbers	86
Comparing Written Methods to Divide Multidigit Numbers	87

Topic 6: Extending Division Strategies

ST Math Objectives: Multi-Digit Division, Multi-Step Problems Using 4 Operations, Factors and Multiples

TEKS: 4.1.A 4.1.B 4.1.C 4.1.D 4.1.E 4.1.F 4.1.G 4.4.B 4.4.C 4.4.D 4.4.E 4.4.F 4.4.H 4.5.A 4.5.B

ELPS: 1.A 2.A 2.C 2.D 3.A 3.E 3.H 4.A 4.B 4.C 4.D 4.E 4.F

Identifying Common Multiples and Factors	89
Doubling and Halving to Find Factor Pairs	90
Exploring Factors and Multiples	91
Using Length Models to Find Factors and Multiples	92
Representing the Standard Division Algorithm with Base Ten Models	93
Representing the Standard Division Algorithm with Area Models	94
Dividing with the Standard Algorithm	95
Solving Problems with Multiplication and Division	96
Modeling and Solving Multistep Word Problems Involving Division	97

Topic 7: Extending Addition and Subtraction to Fractions

ST Math Objectives: Adding and Subtracting Fractions, Mixed Numbers, Fractions - Equivalence and Ordering

TEKS: 4.1.A 4.1.B 4.1.C 4.1.D 4.1.E 4.1.F 4.1.G 4.3.A 4.3.B 4.3.C 4.3.E 4.3.F 4.3.G 4.9.A 4.9.B

ELPS: 1.B 1.C 2.A 2.B 2.E 2.F 3.A 3.B 3.C 3.F 3.G 3.H 4.A 4.B 4.C 4.E 4.F

Introducing Fractions Greater Than 1 as a Sum of Unit Fractions	99
Exploring Fractions Greater Than 1 on a Number Line	100
Identifying Fractions as Mixed and Whole Numbers	101
Partitioning and Iterating Fractions to Compose New Fractions ..	102
Using Bar Models to Decompose Numbers into Sums of Fractions	103
Using Number Lines to Decompose Numbers into Sums of Fractions	104
Connecting Fractions on a Number Line to Rulers and Dot Plots .	105
Using Bar Models to Add and Subtract Fractions with Common Denominators	106
Using Number Lines to Add and Subtract Fractions with Common Denominators	107
Solving Problems with Fractions of Sets	108
Solving Word Problems with Fractions	109
Adding Fractions and Mixed Numbers with Common Denominators	110
Subtracting Fractions and Mixed Numbers with Common Denominators	111
Adding Mixed Numbers with Common Denominators	112
Subtracting Mixed Numbers with Common Denominators ...	113
Using Dot Plots to Solve Mixed Number Addition and Subtraction Problems	114

Topic 8: Exploring Fraction Thinking and Discovering Decimals

ST Math Objectives: Fractions - Equivalence and Ordering, Fraction and Decimal Equivalence, Mixed Numbers

TEKS: 4.1.A 4.1.B 4.1.C 4.1.D 4.1.E 4.1.F 4.1.G 4.2.A 4.2.B 4.2.E 4.2.F 4.2.G 4.2.H 4.3.C 4.3.D 4.3.F 4.3.G 4.8.B

ELPS: 1.C 1.E 2.A 2.B 2.C 2.D 2.E 2.F 3.A 3.F 3.H 4.A 4.B 4.C 4.E 4.F

Using Fraction Strips to Explore Equivalent Fractions	116
Using Bar Models to Make Equivalent Fractions	117
Using Multiplication to Make Equivalent Fractions	118
Using Multiplicative Relationships to Identify Equivalent Fractions	119
Using Division to Make Equivalent Fractions	120
Using Equivalent Fractions to Solve Problems	121
Relating Fractions to Decimals	122
Extending Place Value to Hundredths	123
Relating Tenths and Hundredths	124
Representing Distance with Fractions and Decimals	125
Using Common Denominators and Common Numerators to Compare and Order Fractions	126
Using Benchmarks to Compare and Order Fractions	127
Making Common Denominators to Compare and Order Fractions	128
Comparing and Ordering Fractions to Solve Problems	129

Comparing and Ordering Decimals.....	130
Comparing and Ordering Fractions and Decimals.....	131

Topic 9: Extending Financial Literacy

ST Math Objectives: Decimal Addition and Subtraction, Comparing Decimals, Fraction and Decimal Equivalence

TEKS: 4.1.A 4.1.B 4.1.C 4.1.D 4.1.E 4.1.F 4.1.G 4.10.A 4.10.B 4.10.C 4.10.D 4.10.E 4.2.A 4.2.B 4.2.E 4.2.F 4.2.G 4.3.C 4.3.D 4.4.A 4.5.A 4.5.B 4.8.C 4.9.A 4.9.B

ELPS: 1.E 1.F 2.A 2.B 2.D 2.E 2.F 3.A 3.B 3.C 3.F 3.G 3.H 4.A 4.B 4.C 4.D 4.E 4.F

Adding Tenths and Hundredths	133
Using Models to Add and Subtract Decimals.....	134
Using Place Value Strategies to Add and Subtract Decimals...	135
Creating and Interpreting Stem-and-Leaf Plots with Decimals and Mixed Numbers.....	136
Solving Problems with Money Using Decimal Addition and Subtraction	137
Introducing Fixed and Variable Expenses	138
Using an Allowance to Plan Spending, Saving, and Sharing	139
Solving Problems Involving Business Expenses and Profit...	140
Comparing Savings Options: Home, Checking, and Savings Accounts.....	141
Solving Problems and Making Financial Decisions.....	142

Topic 10: Exploring Shapes, Lines, and Angles

ST Math Objectives: Lines and Angles, Classifying Shapes, Lines of Symmetry

TEKS: 4.1.B 4.1.C 4.1.D 4.1.E 4.1.F 4.1.G 4.6.A 4.6.B 4.6.C 4.6.D 4.7.A 4.7.B 4.7.C 4.7.D 4.7.E 5.1.E

ELPS: 1.A 1.B 1.D 1.E 2.B 2.E 3.D 3.H 4.A 4.B 4.C 4.E 4.F

Exploring Points, Lines, Rays, and Line Segments.....	144
Relating Lines, Rays, and Line Segments	145
Introducing Angles	146
Introducing Degrees	147
Measuring Angles	148
Relating Angles and Estimating Angle Measurements.....	149
Solving Problems Involving Angles.....	150
Sorting, Classifying, and Naming Triangles	151
Sorting, Classifying, and Naming Quadrilaterals.....	152
Using Attributes to Compare Quadrilaterals	153
Introducing Lines of Symmetry	154
Exploring Lines of Symmetry.....	155

Topic 11: Making Connections with Time and Data

ST Math Objectives: Measurement and Conversions, Dot Plots, Multi-Step Addition and Subtraction Problems

TEKS: 4.1.A 4.1.B 4.1.C 4.1.D 4.1.E 4.1.F 4.1.G 4.2.F 4.2.G 4.3.C 4.4.D 4.4.H 4.7.A 4.7.B 4.7.C 4.7.D 4.8.C

ELPS: 1.A 1.E 2.B 2.C 2.D 2.E 2.F 3.F 3.G 3.H 4.A 4.B 4.C 4.E 4.F

Representing Elapsed Time on a Number Line	157
Solving Elapsed Time Word Problems	158
Using Open Timelines to Solve Problems	159
Exploring Angles and Fractions on Clocks	160
Telling Time Using Angles and Fractions	161
Converting Between Units of Time	162
Exploring Patterns with Multiples Involving Time.....	163
Solving Problems with Time-Based Data.....	164
Solving Problems with Time Estimates.....	165

Topic 1

Exploring Multiplicative Relationships

Recommended ST Math Objectives:

Factors and Multiples

Generating Patterns

Multi-Digit Multiplication

Name: _____

Date: _____

Discovering Factor Pairs

- 1 Write an expression to match the drawing.

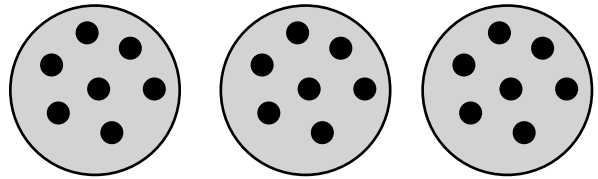

- 2 Solve. $764 + 236 =$

- 3 Some of the factor pairs for 18 are shown.
Which factor pair is missing?

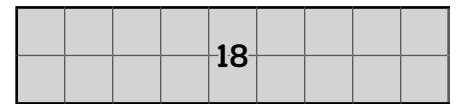
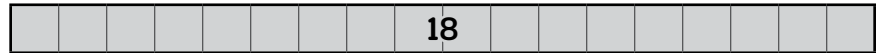

- 4 Draw a line to match the rectangle to each factor pair.

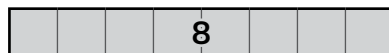
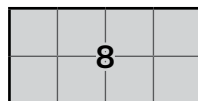

8 and 1

2 and 4

- 5 The school office had 850 dot stickers to label file folders. They used 373 dot stickers on Monday. How many dot stickers did they have left? Explain your thinking.

Did you explain your thinking?



Name: _____

Date: _____



Candace

Exploring Square Numbers

① Use rounding to the nearest ten to answer these questions.

a) What is the least number that will round to 60?

b) What is the greatest number that will round to 60?

② 587 rounded to the nearest 100 is

③ Is 64 a square number? Explain your thinking.

Did you explain your thinking?



④ a) What is the formula for the area of a rectangle?

b) Use the formula to find the area of a rectangular carpet that has a length of 8 feet and a width of 4 feet.

⑤ At 3:20 p.m., Candace worked on chores at home after school. First, Candace cleaned the kitchen for 25 minutes. Then, she spent 4 minutes collecting and taking out the trash. Finally, Candace cleaned her bedroom for 51 minutes. At what time did Candace finish her chores? Explain your thinking.

Did you explain your thinking?



Name: _____

Date: _____



Finding Dimensions of a Rectangle

① Solve. $8 \times 8 = \boxed{}$ $8 \times 80 = \boxed{}$

② Solve. $\boxed{} + 643 = 814$

③ A rectangle has an area of 32 square inches. The width of the rectangle is 4 inches. What is the length of the rectangle?

④ A rectangle has an area of 25 square feet. The length of the rectangle is 5 feet. What is the width of the rectangle?

⑤ Lillian bought a recipe book for \$12. Isaiah bought 3 of the same book for gifts. How much did Isaiah pay for his books? Explain your thinking.

Did you explain your thinking?



Name: _____

Date: _____



Introducing Multiples

① Use the number lines to find a pair of equivalent fractions.

and

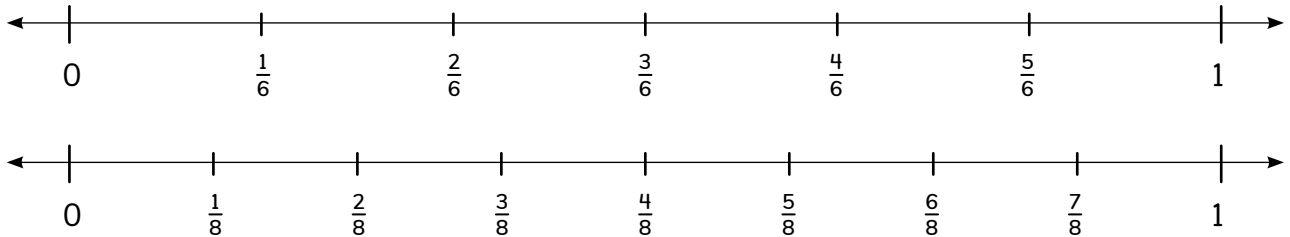

② Is this quadrilateral a trapezoid?

Yes No

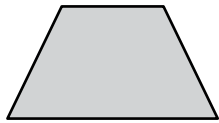

③ Fill in the missing multiples of 3.

3, , , , 15, , , 24, ,

④ 30 is a multiple of 5 because .

⑤ Finn timer had 4 bags of small rocks in her rock collection. Each bag had 22 rocks inside. If Finn timer gave 38 rocks to friends to start their own rock collections, how many rocks does Finn timer have now? Show your thinking

Did you show your thinking?



Name: _____

Date: _____

Representing Patterns with Input-Output Tables

- ① List the factor pairs for 24.

- ② Find the next 5 multiples of 9.

9, , , , ,

- ③

What rule can you apply to the input to get the output?

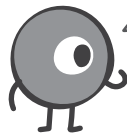

Input	Output
7	21
9	27
15	45
32	

Complete the table with the missing output.

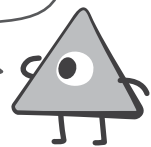

Rule:

- ④ There were 128 people seated on the left side of an auditorium and 115 people seated on the right side. How many people were seated in the auditorium in total?

Name: _____

Date: _____



Candace

Exploring Patterns of Sequences

1

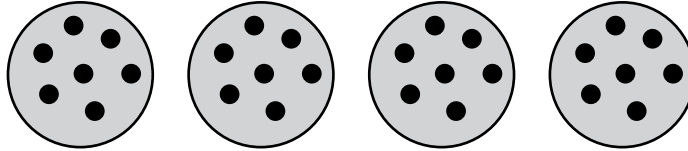

a) Write a multiplication equation to match the drawing.

$$\square \times \square = \square$$

b) Write a division equation to match the drawing.

$$\square \div \square = \square$$

2

Will the product of 5 and 25 be odd or even? How do you know?

3

Will the product of 4 and 39 be odd or even? How do you know?

4

Candace is riding her bike in her neighborhood looking at the numbers on the houses. The number on House 1 is 15. The number on House 2 is 18. The number on House 3 is 21. The next house numbers follow the same pattern. What will the number be on House 7? Did you show your thinking?

Did you show your thinking?



Name: _____

Date: _____



Representing Multiples Plus Some More

- ① Partition the shape into fourths. Shade in $\frac{3}{4}$.

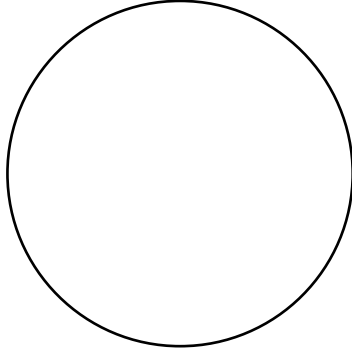

- ② A 1 hour 30 minute movie started at 2:35 p.m. What time did the movie end?

- ③ Is 48 a multiple of 9? Explain your thinking. 

- ④ Complete the statements to make them true.

is a multiple of 7.

48 is NOT a multiple of .

- ⑤ Isaiah is helping to set up 48 folding chairs in the gym. If he wants to make equal rows of chairs for the school play, how many different ways could he arrange the chairs? Which arrangement do you think would be best? Explain your thinking.

Did you explain your thinking?



Name: _____

Date: _____



Using Multiples to Solve Problems

① $\frac{1}{2} =$

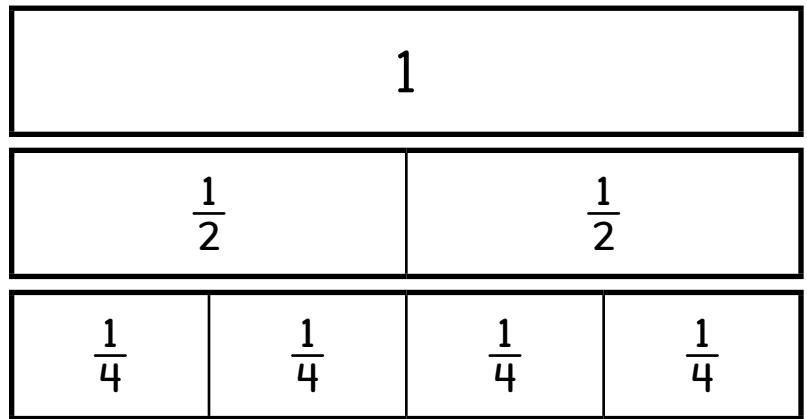

② $1 =$

③ What numbers could you use to make the following equation true?

$$(\square \times \square) + \square = 28$$

④ What number could you use to make the following inequality true?

$$(6 \times 7) + 4 < \square < (6 \times 8) + 4$$

⑤ Dani had 8 boxes of tiles with 12 tiles in each box. She used 17 tiles in the hallway. How many tiles does Dani have left? Solve with an equation.

Did you show your thinking with an equation?



Name: _____

Date: _____



Exploring Multiplication and Division Relationships

1 Solve. $673 - 339 = \boxed{}$

2 Dani collects 30 seashells. She wants to put all of them in bags. She puts 5 seashells in each bag. How many bags does Dani put seashells in?

3 Dani has a board that is 56 inches long. She wants to make shelves that are 8 inches in length.

a) Write an equation that can help Dani find the number of shelves she can build. Use a letter to represent the unknown amount.

b) Solve the equation.

4 Dani's teacher asked the fourth graders to draw a rectangle with an area of 24 square meters. When the teacher looked at the students' work, she saw that the students had drawn different rectangles that each had an area of 24 square meters. Draw 2 different rectangles Dani's class could have drawn and find the perimeter of one of the rectangles.

Name: _____

Date: _____



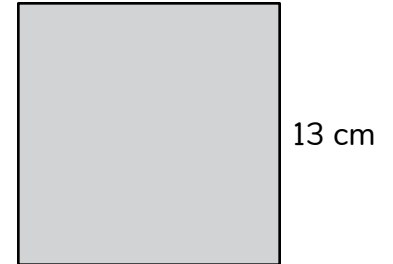

Dividing with Remainders

- 1 a) Find the perimeter of the square. *Show your thinking.* 



- b) Find the area of the square.

- 2 Will there be a remainder when finding the quotient of $42 \div 8$? *Explain your thinking.* 

- 3 Is 36 divisible by 9? *Explain your thinking.* 

- 4 Dani has 17 boards for her and her 2 friends to share equally for a project. How many boards does each person get for their project?

Name: _____

Date: _____



Interpreting Remainders

- 1 Which is the better estimate for the weight of an apple?
100 ounces or **100 pounds**

- 2 Solve. $7 \times 80 = \boxed{}$

- 3 Candace's soccer team is taking vans to their next game. There are 28 players and each van can hold 6 players. Write an equation to show how many vans, v , will be needed.

- 4 Using your work from Problem 3, determine how many vans will be needed to take the team to the game.

- 5 Candace needs at least 400 paper plates for the soccer cookout on Friday. She finds bags of paper plates in the supply closet. One bag has 97 plates, another bag has 111 plates, another bag has 102 plates, and the last bag has 78 plates. Estimate to determine if Candace will have enough plates. Explain your thinking.

Did you explain your thinking?



Name: _____

Date: _____



Candace

Solving Division Word Problems with Remainders

- 1 a) How many more students like kickball than those who like jumping rope?



Kickball

- b) How many students were asked what activity they liked to do at recess?





Chalk

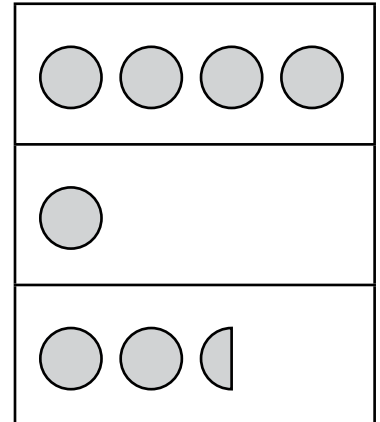

Jump Rope

Recess Activities Preferred by Students



Key:  = 4 students

- 2 My number is a multiple of 3.
It is an even number.
My number is less than 30.
8 is a factor of my number.
Guess my number.



- 3 What shape is the 27th figure? *Explain your thinking.* 

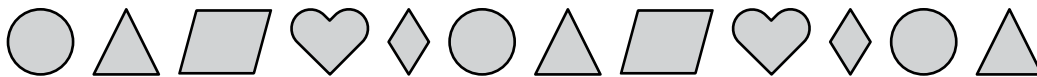

- 4 Candace has 60 party favors. She wants to put an equal number of party favors in each bag. What are 4 different ways Candace could organize party favors into bags? Which way uses the fewest bags? Which way uses the most bags?

Topic 2

Discovering Multiplicative Comparison

Recommended ST Math Objectives:

Multi-Digit Multiplication

Applying Area and Perimeter

Factors and Multiples

Name: _____

Date: _____

Introducing Multiplicative Comparison

- 1 List the factor pairs for 36.

- 2 Circle the operation you would use to find the length of each object.

A

3 cm 3 cm 3 cm 3 cm 3 cm 3 cm

Addition Multiplication

B

3 cm

3 cm 15 cm

Addition Multiplication

- 3 A cat's tail is 3 times as long as the tail of a mouse. If the length of a mouse's tail is 4 inches, how long is a cat's tail?

- 4 Two friends want to have a party to celebrate the track season. They have 2 rolls of streamers to decorate for the party. One roll of streamers is 48 feet long. The other roll of streamers is 36 feet long. If they use 60 feet of streamers, how much is left over? Explain your thinking.

Did you explain your thinking?



Name: _____

Date: _____



Candace

Using Multiplicative Comparison to Solve Problems

- ① Solve.

$9 \times 5 = \square$

$8 \times 6 = \square$

$7 \times 7 = \square$

- ② Will the product of 24×3 be odd or even?

Explain your thinking.



③



a) The bar is times as long as the bar.

b) If the white bar is 24 centimeters long, what is the length of each gray bar?

Show your thinking with an equation.



- ④ Candace is going to a professional soccer game and wants a new outfit. She bought sunglasses, jeans, and a T-shirt for \$12 each. How much did Candace pay for the outfit? Show your thinking with an equation.

Did you explain your thinking?



Name: _____

Date: _____



Representing Multiplicative Comparison

- ① A square garden has an area of 25 square feet. What is the length of each side?

② Solve. $549 + 287 = \boxed{}$ $382 + 459 = \boxed{}$

③ a) $\boxed{}$ is 4 times as much as 3.

b) $\boxed{}$ is 6 times as much as 8.

- ④ 7 kids like the swings at the park. 3 times as many kids like the climbing bars as like the swings. How many kids like the climbing bars?

- ⑤ Dani and her older brother went to the hardware store to pick up supplies for some projects. Dani spent \$7. Her older brother spent 9 times as much money as Dani. How much money did Dani's older brother spend? Explain your thinking.

Did you explain your thinking?



Name: _____

Date: _____



Exploring Multiplicative Comparison

- 1 Complete the pattern by filling in the missing numbers.

, , 16, 20, 24, ,

- 2 Fill in the missing multiples of 6.

6, 12, , , , , , 48, ,

- 3 Yesterday, Logan read 35 pages of her graphic novel. Her friend said that Logan read 5 times as many pages as he did. Complete the strip diagram to show how many pages Logan's friend read.

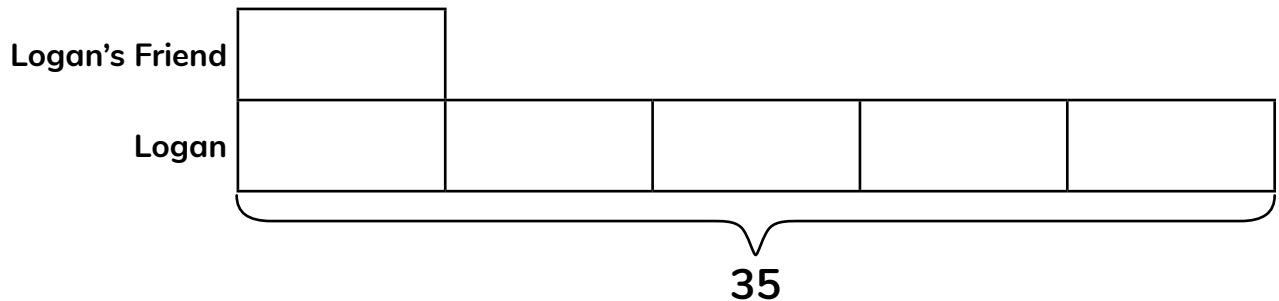

- 4 a) 54 is times as much as 9. b) 48 is times as much as 6.

- 5 Dani and her older brother like to play video games together. On Monday, Dani scored 12 points and her older brother scored 72 points. How many times as many points did Dani's older brother score compared to her? Show your thinking.

Did you show your thinking?



Name: _____

Date: _____



Logan

Dani

Using Multiplicative Comparison to Find Unknowns



① Solve. $48 \div 6 = \square$

$27 \div 3 = \square$



② Solve. $7 = \square \div 6$

$4 = \square \div 4$

- ③ The lifespan of a carpenter ant is \square times the lifespan of a cabbage white butterfly.

		Lifespan
Cabbage White Butterfly		21 days
Carpenter Ant		84 days

- ④ Draw a strip diagram to show that the lifespan of a firefly is 4 times as long as the lifespan of a monarch butterfly.

		Lifespan
Monarch Butterfly		2 weeks
Firefly		8 weeks

- ⑤ Logan has 5 times as many stickers in her sticker book as Dani has in her sticker book. If Logan has 30 stickers, how many stickers does Dani have? Show your thinking.

Did you show your thinking?



Name: _____

Date: _____



Logan

Representing Additive and Multiplicative Input-Output Relationships

1 Solve.

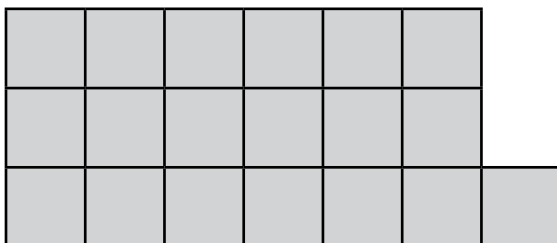

$$19 \div 3 = \boxed{} \text{ R } \boxed{}$$

2 Write an expression to represent the length of the pencil.



3 What rule shows how I can use the position number to find the value?

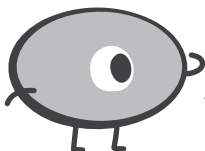

Complete the table.

Position	Value
1	10
2	11
3	12
43	
65	

Rule: $\bigcirc \boxed{}$

4 Logan surveyed her class to see if other kids like comic books and found out that 7 kids like comic books. She also found out that 3 times as many kids like mystery novels. How many kids like mystery novels? Write an equation to show how you know.

Did you explain your thinking with an equation?



Name: _____

Date: _____



Sarah

Converting Yards to Feet

① Solve. $4 \times 6 = \boxed{}$ $4 \times 60 = \boxed{}$

② If $\boxed{} \times 8 = 56$, then $56 \div 8 = \boxed{}$.

③ There are 3 feet in 1 yard. Find each measurement conversion.

3 yards = $\boxed{}$ feet 6 yards = $\boxed{}$ feet

④ Sarah gardens in a planting bed that is 42 feet long. Her dad gardens in a planting bed that is 13 yards long. Which planting bed is longer?

Explain your thinking.



⑤ Sarah needs 12 total yards of rope. One spool has 21 feet of rope. Another spool has 12 feet of rope. Does she have enough rope? Explain your thinking.

Did you explain your thinking?



Name: _____

Date: _____

Converting Between Customary Length Measurements

① List all the factor pairs for 24.

② Write the number in expanded notation.

863,241

③ There are 12 inches in a foot. Find each measurement conversion.

4 feet = inches

7 feet = inches

5 feet = inches

④ A roll of string is 72 inches long. If 2 necklaces are made that each use 1 foot of string, how much string is left? Explain your thinking.

Did you explain
your thinking?



Name: _____

Date: _____



Solving Problems with Customary Length Conversions

- 1 Write the number in expanded notation.

703,050

2 Solve. $604 - 348 = \square$

$783 - 596 = \square$

- 3 Candace's bed is 75 inches long. Her blanket is 7 feet long. How much longer is her blanket than her bed?

Explain your thinking.



- 4 Use $<$, $=$, or $>$ to compare.

$5'8'' \bigcirc 64''$

$54'' \bigcirc 4'6''$

- 5 Louis needs 72 inches of extension cord to be able to set up his video game system. His stepdad buys him an extension cord that is 6 feet long. Does Louis have a long enough cord? Explain your thinking.

Did you explain your thinking?



Name: _____

Date: _____



Converting Between Pounds and Ounces

- ① Solve.

$24 \div 4 = \square$

$45 \div 5 = \square$

$54 \div 6 = \square$

- ② A school collected cans for a food drive. Each of the 7 classrooms collected 30 cans. How many cans did the school collect for the food drive?

- ③ Complete the chart.

Pounds	Ounces
1	16
2	
3	
4	

- ④ Use $<$, $=$, or $>$ to compare.

2 lb 3 oz 29 ounces

52 ounces 3 lb 15 oz

- ⑤ Logan's dad bought 5 pounds of potatoes so they could make mashed potatoes together. How many ounces of potatoes did he buy? Explain your thinking.

Did you explain your thinking?



Name: _____

Date: _____

Converting Between Customary Units of Liquid Volume

1 What are all of the possible lengths and widths that a rectangle could be if the area is 36 square inches?

2 The area of a rectangle is 24 square inches. The length of the rectangle is 6 inches. What is the width?

3 Use $<$, $=$, or $>$ to compare.

1 cup = 8 fl oz
1 pint = 2 cups
1 quart = 2 pints
1 gallon = 4 quarts

3 pints ○ 12 fluid ounces

4 cups ○ 1 quart

8 pints ○ 1 gallon

4 A recipe calls for 18 fluid ounces of buttermilk. There is 1 pint of buttermilk in the refrigerator. Is there enough to make the recipe? Explain your thinking. 

5 A pet store has different-sized aquariums for fish. One aquarium holds 32 quarts of water. How many gallons does this aquarium hold? Explain your thinking.

Did you explain your thinking?



Name: _____

Date: _____



Converting Units to Solve Problems

- ① Plot $\frac{1}{4}$ and $\frac{5}{4}$ on the number line.

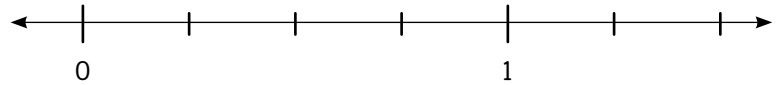

② Solve. $743 + 195 = \boxed{}$ $261 + 692 = \boxed{}$

- ③ Use $<$, $=$, or $>$ to compare. 1 pound = 16 ounces

3 lb 8 oz 40 oz

38 oz 2 lb 6 oz

- ④ Finish each statement.

14 is times as much as 2.

is 8 times as much as 9.

- ⑤ Logan's track club went to the bowling alley to celebrate the track season. Logan used a bowling ball that weighed 9 pounds. What was the weight of her bowling ball in ounces? Explain your thinking.

Did you explain your thinking?



Name: _____

Date: _____



Logan

Solving Problems with Mixed Customary Measurement Units

- ① Solve.

$$850 - 392 = \boxed{}$$

$$227 + 581 = \boxed{}$$

- ② What is the length of the rectangle?

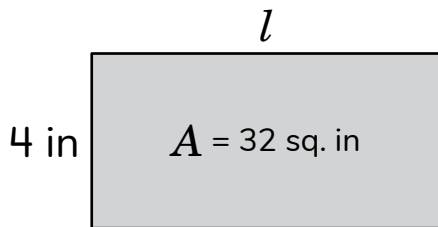

$$l = \boxed{}$$

- ③

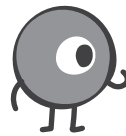

1 pound = 16 ounces

I have 2 bags.
The first bag weighs
7 pounds 9 ounces.
The second bag weighs
5 pounds 14 ounces.

What is the difference in
weight between the 2 bags
in pounds and ounces?

- ④ Logan had some money. She bought items that cost a total of \$42 and got \$8 back in change. How much money did Logan start with?

Topic 3

Extending Place Value and Adding and Subtracting Efficiently

Recommended ST Math Objectives:

Using Place Value

Addition and Subtraction Algorithm

Rounding Whole Numbers

Name: _____

Date: _____



Sarah

Exploring Multiplication Relationships Between Place Values

① 42 is times as much as 6.

② Solve. $\times 8 = 72$

$48 \div$ $= 6$

③ Complete the relationship of these place values.

hundred	ten	one	hundred	ten	one	hundred	ten	one
Millions			Thousands			Ones		

a) 1 thousand is as much as 1 hundred. b) $1,000 =$ $\times 100$

④ 100 million is 10 times as much as what number?

⑤ Sarah's teacher asked her class to write a 5-digit number. Sarah wrote 15,284. Write another number in which the 5 has 10 times the value of the 5 in Sarah's number. Explain your thinking.

Did you explain your thinking?



Name: _____

Date: _____



Candace

Exploring Multiplication and Division Relationships Between Place Values

- ① What is a related multiplication fact for $35 \div 7 = 5$?

$$\square \times \square = \square$$

- ② A lap around the block is 2 miles. The trail around the lake is 6 times as long as the lap around the block. How long is the trail around the lake?

- ③ Complete each statement.

1,000 is **one tenth**
ten times as much as 10,000.

1,000,000,000 is **one tenth**
ten times as much as 100,000,000.

- ④ Candace scored 7,000 points in a soccer video game. If Candace scored 10 times as many points as her dad, how many points did her dad score? Explain your thinking.

Did you explain your thinking?



Name: _____

Date: _____



Representing Large Numbers

- ① What fraction of the circle is shaded?

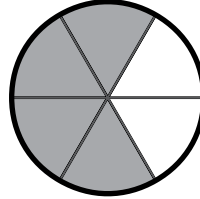

- ② Soccer practice started at 2:25 p.m. It lasted 90 minutes. What time was practice over?

- ③ Write the number in standard form.

$$(3 \times 10,000) + (4 \times 1,000) + (7 \times 100) + (8 \times 1)$$

- ④ Write the number in expanded notation.

ten million thirty-six thousand four hundred twenty-two

- ⑤ Candace wrote the number 29,037 in expanded notation. She wrote $(2 \times 10,000) + (9 \times 1,000) + (3 \times 100) + (7 \times 1)$. Is Candace correct? Explain your thinking.

Did you explain
your thinking?



Name: _____

Date: _____

Multiplying and Dividing by 10, 100, and 1,000

- ① Use the model to write the fraction.

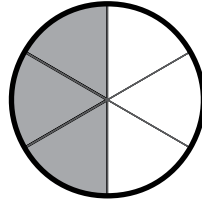

$$\frac{\boxed{}}{\boxed{}} = \frac{1}{2}$$

- ② Complete the table.

Inches	12				
Feet	1	2	3	4	5

- ③ Solve.

$$17,000 \div 1 = \boxed{} \quad 17,000 \div 10 = \boxed{}$$

$$17,000 \div 100 = \boxed{}$$

- ④ Solve.

$$26 \times 1,000 = \boxed{} \quad 26 \times 10,000 = \boxed{}$$

- ⑤ Two friends counted 346 shells on the beach. They estimated there were 100 times as many shells in the tide pools as on the beach. How many shells did they estimate were in the tide pools? Explain your thinking.

Did you explain your thinking?



Name: _____

Date: _____

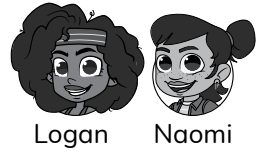

Converting Metric Units

- 1 Complete each measurement conversion.

$$1 \text{ yard} = \boxed{} \text{ feet} \quad 1 \text{ foot} = \boxed{} \text{ inches}$$

- 2 Logan got a new graphic novel. She read 7 pages on Sunday. Her dad challenged her to read 7 times as many pages by Friday. How many pages does Logan need to read to complete the challenge?

- 3 Naomi got a new tank for her hermit crab. This tank holds 42 liters of water. How many milliliters of water does the tank hold?

Show your thinking. 

1 liter = 1,000 milliliters

1 meter = 1,000 millimeters

- 4 Use $<$, $=$, or $>$ to compare. 5,000 millimeters  50 meters

- 5 On a race day, Logan drinks 2,000 mL of water. How many liters does Logan drink? Explain your thinking.

Did you explain your thinking? 

Name: _____

Date: _____

Estimating and Converting Metric Units of Mass

- 1 Circle all the ways to describe the number 32.

multiple of 3

multiple of 2

square number

even

divisible by 4

odd

- 2 Write a multiplication equation to represent the strip diagram. Use a letter for the unknown.

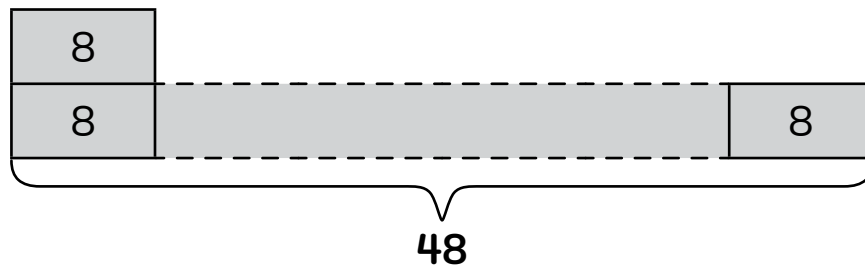

3 $28 \text{ kg} = \text{ } \text{g}$

$345,000 \text{ g} = \text{ } \text{kg}$

1 kilogram (kg) = 1,000 grams (g)

- 4 There are 30 stickers to be shared equally among 4 students. How many stickers will be left over? Explain how you know.

Did you explain your thinking?



Name: _____

Date: _____

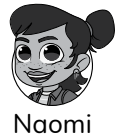

Comparing Large Numbers

- 1 Complete each statement.

558 rounded to the nearest 10 is .

558 rounded to the nearest 100 is .

- 2 There are 33 students in a fourth-grade class. Each table in the classroom can seat 4 students. How many tables will they need so each student has a seat?

 Explain your thinking.

- 3 Use $<$, $=$, or $>$ to compare.

2,403,971 2,304,971 5,008,981 5,009,980

- 4 Write a digit that will make the inequality true.

423,628 $<$ 3,628

4,570 $<$ 334,570

- 5 Naomi was born in a city with a population of 913,175. Naomi's sister was born in a city with a population of 985,843. Who was born in the city with the greater population? Compare the population of each city using $<$, $>$, or $=$.

Name: _____

Date: _____

Rounding Large Numbers

① Solve. $600 - 429 = \square$

② Complete the table.

Ounces	16				
Pounds	1	2	3	4	5

③ If this number rounds to 180,000, what digit might be under the ?

18  403

④ a) Round 534,496 to the nearest hundred thousand.

b) Round 534,496 to the nearest ten thousand.

⑤ An online store receives 843 orders for key chains. The website fills 455 orders. How many orders does the website still have to fill? Show your thinking.

Did you explain your thinking?



Name: _____

Date: _____

Reasoning with Large Numbers to Solve Problems

- ① Solve.

$6 \times 9 = \square$

$3 \times 7 = \square$

$5 \times 5 = \square$

- ② What happens when a number is multiplied by 0?

- ③ Write the number in standard form.

$$(5 \times 1,000) + (1 \times 100) + (1 \times 10) + (8 \times 1)$$

- ④ There are 1,000 grams in a kilogram. Circle the bag of trash that has the greater mass.

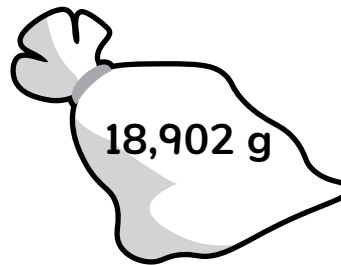
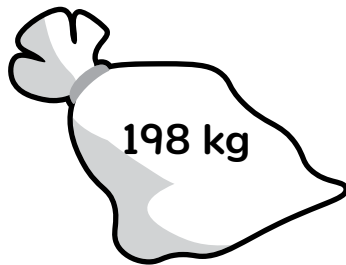

Show your thinking.



- ⑤ The city needs 24,533 flyers announcing the citywide Clean Beach event. If the flyers are printed in batches of 1,000, how many batches of flyers should the city request? Show your thinking.

Did you explain your thinking?



Name: _____

Date: _____



Hannah

Creating Stem-and-Leaf Plots

- 1 Complete each statement.

5,000 is one tenth as much as .

is 10 times as much as 300.

- 2 Complete the inequalities.

85,291,357 < 39,857 300,132

- 3 Number of Minutes
Students Read Last Week

Stem	Leaf
7	0 4 5 5 7 9
8	2 5 7
9	6
10	0 0 0 3 5 8
11	1 3 4 6 6

7|4 means 74 minutes.

What is the most common number of minutes read?

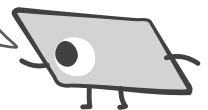

What is the least number of minutes read?



- 4 Hannah read 48 pages of her book on Monday and 12 pages of her book on Tuesday. Which statements describe how much Hannah read on Monday and Tuesday?

- a) Hannah read 4 times as much of her book on Tuesday as on Monday.
- b) Hannah read 4 times as much of her book on Monday as on Tuesday.
- c) Hannah read 36 fewer pages on Tuesday than on Monday.
- d) Hannah read 60 more pages on Monday than on Tuesday.

Name: _____

Date: _____



Logan

Adding and Subtracting Large Numbers on an Open Number Line

- ① What are 2 different names for this shape?



- ② Logan ran a race at school. She ran 4 laps. Her dad challenged her to run 6 times as many laps over the weekend. How many laps would Logan have to run to complete the challenge?

- ③ Use the number line to find the sum of $876 + 2,434$.



- ④ Use the number line to find the difference of $4,206 - 1,892$.



- ⑤ Volunteers at the beach cleanup picked up 1,118 aluminum cans in the first hour and 1,074 aluminum cans in the second hour. How many total aluminum cans were picked up at the beach cleanup? Explain your thinking.

Did you explain your thinking?



Name: _____

Date: _____



Estimating Sums and Differences of Large Numbers

- 1 What time does the clock show?

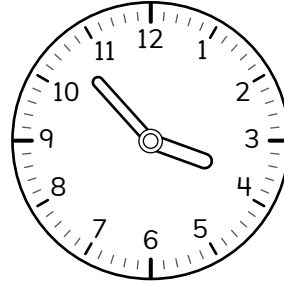
 :

- 2 A square has a side length of 8 inches. What is the area of the square?

- 3 a) Round each addend to the nearest hundred and estimate the sum. **1,962 + 947**

- b) Round each addend to the nearest ten and estimate the sum. **1,962 + 947**

- c) Will rounding to the nearest hundred or rounding to the nearest ten give an estimate closer to the actual sum?

Explain your thinking.



- 4 Hannah and her dad went on a road trip! They drove 1,182 miles from New York, New York, to Orlando, Florida. Then they drove 963 miles to Houston, Texas. They finally drove 1,545 miles to Los Angeles, California. Round each distance to the nearest thousand, and then estimate the total number of miles Hannah and her dad traveled. Explain your thinking.

Did you explain your thinking?



Name: _____

Date: _____

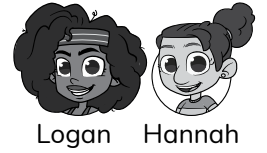

Modeling and Solving Addition and Subtraction of Large Numbers

1 Solve.

$8 \times 3 = \square$

$9 \times 6 = \square$

$7 \times 8 = \square$

2 Logan and her dad went to a track-and-field competition together. She threw the shot put 11 feet. Her dad threw the shot put 3 yards. Who threw the shot put farther?

3 Using the partial sums strategy, find each sum.

Show your thinking.



	3,	4	8	6
+		6	5	5
<hr/>				

	6,	0	2	9
+	2,	5	1	7
<hr/>				

4 Hannah and her dad harvested 9,688 pounds of corn from their farm this year. They harvested 8,932 pounds of corn last year. How many total pounds of corn has Hannah's family harvested in the last 2 years? Show your thinking.

Did you explain your thinking?



Name: _____

Date: _____

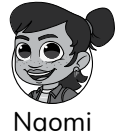

Adding and Subtracting Large Numbers Without Regrouping

- 1 Complete each statement.

is 5 times as much as 8.

48 is 8 times as much as .

- 2 A recipe calls for 2 pounds of green beans. A bag has 30 ounces of green beans. Are there enough green beans to make the recipe?

Explain your thinking.



- 3 a) Estimate the sum of $719 + 275$.

b) Solve without using partial sums.

$$\begin{array}{r} 719 \\ + 270 \\ \hline \end{array}$$

- 4 Naomi used the partial sum strategy to determine the number of visitors the city aquarium had one weekend. There were 2,689 visitors on Saturday and 3,078 visitors on Sunday. How many total visitors went to the aquarium that weekend? Explain your thinking.

Did you explain your thinking?



Name: _____

Date: _____



Hannah

Adding Large Numbers with Regrouping

- 1 What multiplication equation could be used to find the quotient of $56 \div 7$?

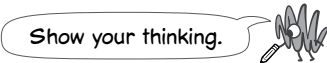
- 2 The owners of a concession stand ordered hot dogs for the game. Hot dogs come in packages of 8. The owners ordered 30 packages of hot dogs. They need to make sure they have enough hot dog buns. Buns come in packages of 10. How many packages of hot dog buns do they need to order?

- 3 a) Estimate the sum of $873 + 459$.

b) Use the standard algorithm to find the sum of $873 + 459$.

- 4 Hannah looked at how many hits her favorite baseball team had in the last 2 years. In the first year, the team had 1,236 hits. In the second year, the team had 995 hits. How many hits did Hannah's favorite team have during the past 2 years?
Show your thinking.

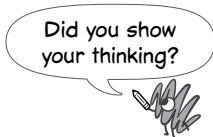

Did you show your thinking?

Name: _____

Date: _____



Subtracting Large Numbers with Regrouping

1 Write the factor pairs for 48.

2 a) Continue the pattern.

272, 264, 256, , , ,

b) What is the rule for this pattern?

3 a) Estimate the difference of $1,254 - 382$.

b) Use the standard algorithm to find the difference of $1,254 - 382$.

4 Hannah's favorite baseball team scored 1,032 runs last season but only 789 runs this season. How many fewer runs did the team score this season than last? Show your thinking.

Did you show
your thinking?



Name: _____

Date: _____



Hannah

Reinforcing the Addition and Subtraction Standard Algorithms

- ① Solve.

$$42 \div 6 = \boxed{} \quad 40 \div 8 = \boxed{} \quad 24 \div 6 = \boxed{}$$

- ② A new football is \$9. A new pair of cleats costs 5 times as much. How much does a new pair of cleats cost?

- ③ a) Estimate the difference. $4,000 - 1,374 = \boxed{}$

b) Use the standard algorithm to find the difference.

$$4,000 - 1,374 = \boxed{}$$

- ④ Hannah and her dad sold \$3,000 of goods at the farmers market in September. They spent \$1,856 on supplies to grow and take care of the goods they sold. What is the difference between the price they sold the goods for and the amount they spent to grow and care for them? Explain your thinking.

Did you explain your thinking?



Name: _____

Date: _____



Hannah

Solving Multistep Problems Involving Addition and Subtraction of Large Numbers

- 1 Create a shape that has an area of 24 square units.

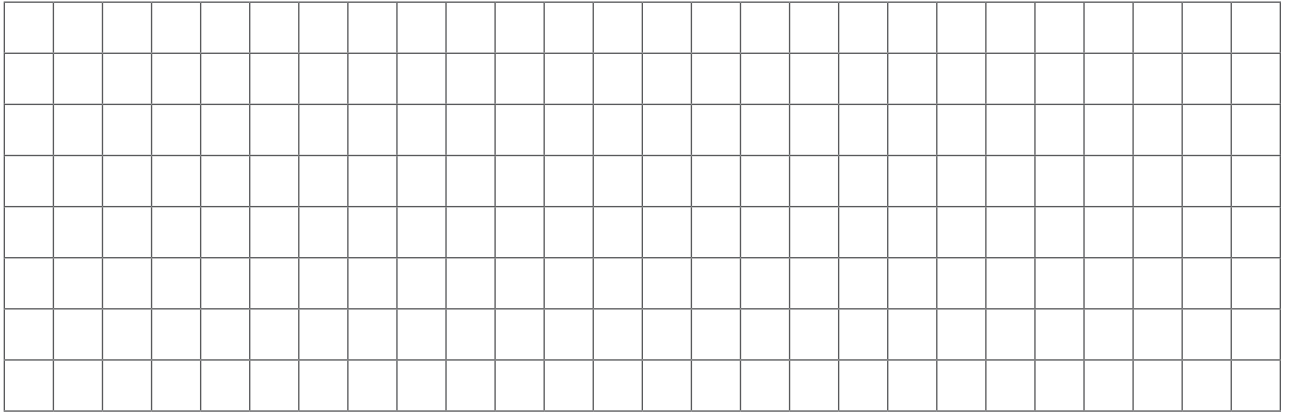

- 2 What is important to remember when multiplying a number by 1?

- 3 Solve.

$$12,065 + 8,953 = \boxed{}$$

$$15,134 - 9,857 = \boxed{}$$

- 4 Hannah and her dad went to the county fair. This year's winning pumpkin weighed 2,471 pounds. The second-place pumpkin weighed 2,299 pounds. What was the total weight of the first-place and second-place pumpkins? Explain your thinking.

Did you explain your thinking?



Topic 4

Extending Multiplication to Multidigit Whole Numbers

Recommended ST Math Objectives:

Multi-Digit Multiplication

Factors and Multiples

Generating Patterns

Name: _____

Date: _____

Using Place Value and Factors to Represent Large Numbers

1 How can base ten blocks show the relationship between 4, 40, and 400?

2 What is the value of the underlined digit in 84,345?

3 Fill in the blanks to complete the pattern.

A

50,000 = 50,000 ones

50,000 = tens

50,000 = hundreds

50,000 = 50 thousands

50,000 = ten thousands

B

50,000 = × 1

50,000 = × 10

50,000 = 500 × 100

50,000 = × 1,000

50,000 = × 10,000

4 A baseball stadium has 20,000 seats. The seats are grouped into 100 sections that each have the same number of seats. How many seats are in each section? Show your thinking.

Did you show your thinking?



Name: _____

Date: _____

Using Place Value Reasoning to Multiply 10, 100, and 1,000

① Write 456,873 in expanded notation.

② Complete each statement.

is 100 times as much as 6.

70 is times as much as 7.

③ Use place value patterns to help you find each product.

$$3 \times 70 = \text{$$

$$8 \times 6 = \text{$$

$$3 \times 700 = \text{$$

$$8 \times 60 = \text{$$

④ One way to find the product of 9×500 is to think of $9 \times \text{$ $\times 100$.

Another way to find the product of 9×500 is to think of $9 \times 50 \times \text{$.

⑤ 4 boxes of jalepeño peppers were sold at the farmers market. 40 jalepeño peppers were in each box. How many jalepeño peppers were sold at the farmers market? Explain your thinking.

Did you explain your thinking?



Name: _____

Date: _____



Logan

Using Place Value Reasoning to Multiply Multiples of 10

- ① Which symbol makes the inequality true? Use $<$, $>$, or $=$.

$$65,839 \bigcirc 65,938$$

- ② Complete each statement.

5,759 rounded to the nearest 1,000 is .

5,759 rounded to the nearest 100 is .

- ③ What is the product of 80×70 ? Explain your thinking. 

- ④ An author sold 40 books at a book fair yesterday. Today, the author sold 3 times as many books as yesterday. How many books did the author sell today? Show your thinking. 

- ⑤ Logan read 30 graphic novels in third grade. This year, she wants to read 3 times as many graphic novels. How many graphic novels does Logan want to read this year? Show your thinking.

Did you show your thinking?



Name: _____

Date: _____

Exploring Strategies to Multiply Two-Digit Numbers

- ① Solve.

$$9,567 + 3,298 = \boxed{}$$

$$2,289 + 6,372 = \boxed{}$$

- ② Circle the fraction that equals 4.

$$\frac{4}{4}$$

$$\frac{4}{1}$$

$$\frac{1}{4}$$

Explain your thinking.



- ③ Multiply 17×3 .

Show your thinking.



- ④

Multiply 26×4 .

Show your thinking.



- ⑤ The manager of a craft store ordered paintbrushes. The first box had 12 paintbrushes. The second box had 8 times as many paintbrushes as the first box. How many paintbrushes were in the second box? Show your thinking.

Did you show your thinking?



Name: _____

Date: _____

Multiplying Two-Digit Numbers with the Distributive Property

- ① Solve.

$$\begin{array}{r} 229,406 \\ + 457,513 \\ \hline \end{array}$$

- ② How many pints are in 8 cups?

1 pint = 2 cups

- ③ Use the horizontal partial products algorithm to find the value of the expression.

$$\begin{aligned} 6 \times 43 &= \boxed{} \times (\boxed{} + \boxed{}) \\ &= (\boxed{} \times \boxed{}) + (\boxed{} \times \boxed{}) \\ &= \boxed{} + \boxed{} \\ &= \boxed{} \end{aligned}$$

- ④ 28 clowns perform at the circus. 8 clowns fit into 1 clown car. What is the fewest number of cars they need to have all of the clowns start the show in a car? Explain your thinking.

Did you explain your thinking?



Name: _____

Date: _____

Multiplying Two-Digit Numbers with Multiple Strategies

① $30,000 = \square$ thousands

② Solve.

$$\begin{array}{r} 6,132 \\ - 2,937 \\ \hline \end{array}$$

③ Solve using the standard algorithm and the area model.

$$\begin{array}{r} \square \\ 54 \\ \times 6 \\ \hline \square \square \square \end{array}$$

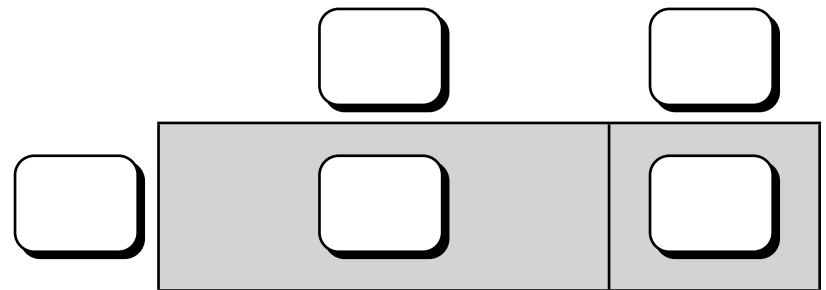

④ The art teacher bought a 3-pack of shelves. Each shelf is 1'4" long. What is the total length of all 3 shelves in inches? Explain your thinking.

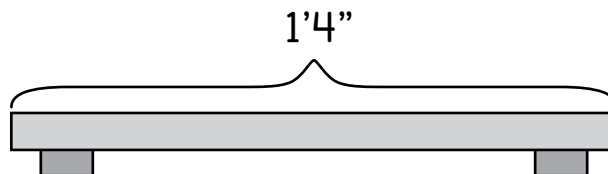

1 foot = 12 inches

Name: _____

Date: _____

Multiplying up to Four Digits with Multiple Strategies

- ① Complete the table.

Position	Expression	Value
1	1×4	4
2		8
3		12
6		

- ② Solve using the standard algorithm.

$$\begin{array}{r} 17 \\ \times 9 \\ \hline \end{array}$$

- ③ Solve using vertical partial products.

$$\begin{array}{r} 782 \\ \times 5 \\ \hline \end{array}$$

←

←

+←

- ④ Louis is making bread rolls for the shelter. 4 ounces of flour are needed to make each bread roll. How many ounces of flour are needed to make 255 bread rolls? Show your thinking.

	700	80	2
5	5×700	5×80	5×2

Did you show your thinking?



Name: _____

Date: _____

Multiplying up to Four Digits with the Standard Algorithm

- ① What will the product of 6×803 be?

even

odd

How do you know?

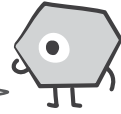

- ② Solve using the number line.

$$578 + 3,849 = \boxed{}$$

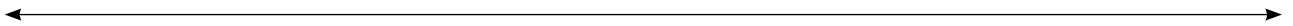

- ③ Use the standard algorithm to find each product.

$$\begin{array}{r} 186 \\ \times 4 \\ \hline \end{array}$$

$\boxed{}$

$$\begin{array}{r} 809 \\ \times 8 \\ \hline \end{array}$$

$\boxed{}$

- ④ A square rug has an area of 36 square feet. What are the side lengths of this rug?

Name: _____

Date: _____

Solving Multiplication Word Problems with the Standard Algorithm

① $90 \times 80 =$

② What will be the 61st shape? How do you know?

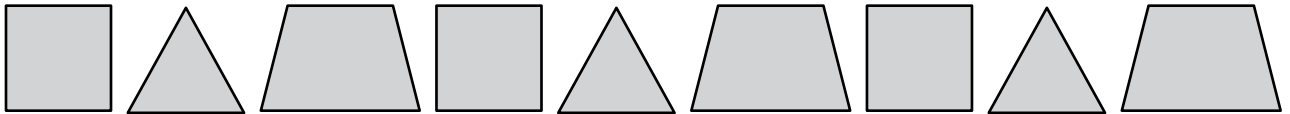

③  An adult hippo eats about 8,750 grams of grass per feeding.

How much grass does the hippo eat in 4 feedings?

④ Louis's class learned some cool facts at the zoo about how high certain animals can jump. Which of these animals can jump the highest?

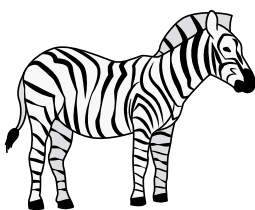

A zebra can jump 2 yd.



A grasshopper can jump 30 in.

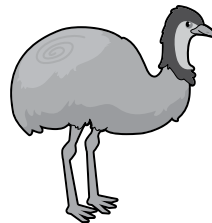

An emu can jump 7 ft.

1 yard (yd) = 3 feet (ft)
1 foot (ft) = 12 inches (in)

Name: _____

Date: _____



Using Area Models to Multiply Two-Digit by Two-Digit Numbers

- ① Draw arrows on the clock to show the time 10:47.

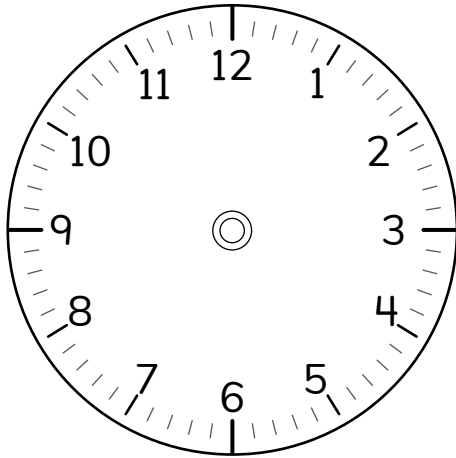

- ② The rock concert was 3 hours and 15 minutes long. The concert ended at 9:45 p.m. At what time did the concert begin?

- ③ Draw an open area model to find each product.

a) $4 \times 3,162$

b) 57×89

- ④ Mateo's abuela bought him packages of different-colored squares of paper to make another kind of mosaic. She bought Mateo 15 packages of squares. Each package has 48 squares inside. How many paper squares does Mateo have in all? Show your thinking.

Did you show your thinking?



Name: _____

Date: _____



Louis

Writing Partial Products to Multiply Two-Digit by Two-Digit Numbers

- 1 a) Continue the pattern.

$7 + 8 = \boxed{}$

$70 + 80 = \boxed{}$

$700 + 800 = \boxed{}$

- b) What do you notice about the sums?

- 2 What problem does this model represent?

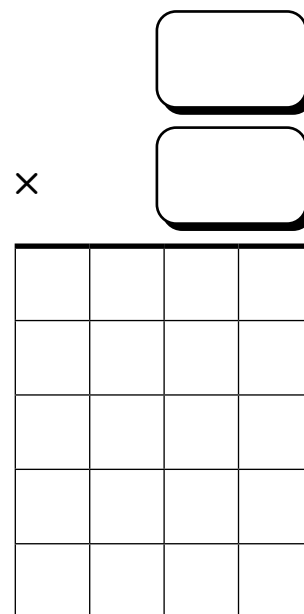
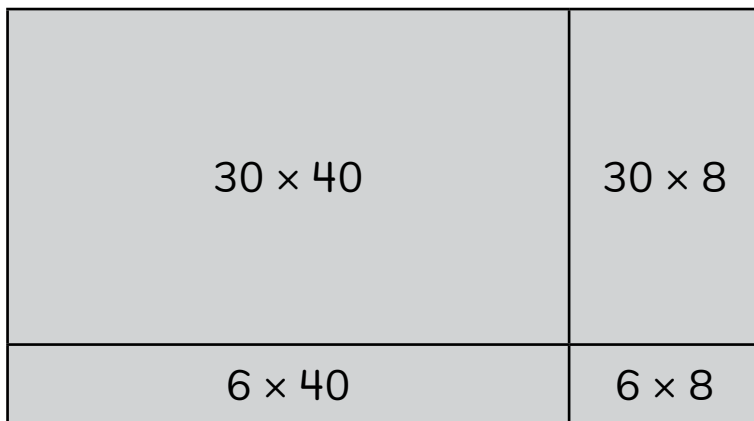

- 3 Fill in the missing blanks to complete the open area model.

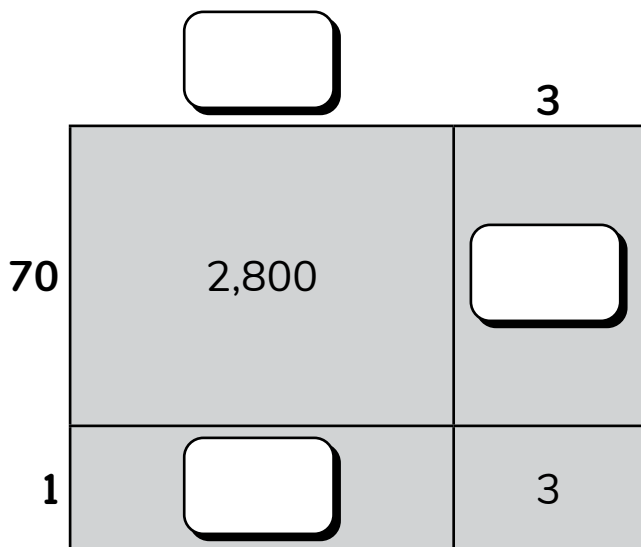

- 4 Louis and his stepdad are cooking spaghetti and meatballs for a large group of people tonight. They bought 35 bags of meatballs. If each bag contains 24 meatballs, how many total meatballs are there? Show your thinking.

Did you show your thinking?



Name: _____

Date: _____

Multiplying Two 2-Digit Numbers with the Standard Algorithm

① Find the missing multiples of 9. 9, 18, , , 45, 54,

② The area of a rectangle is 32 square feet. If the length of the rectangle is 4 feet, what is its width?

③ $34 \times 26 = \text{$

Solve using the area model.
Then, solve using the standard algorithm.

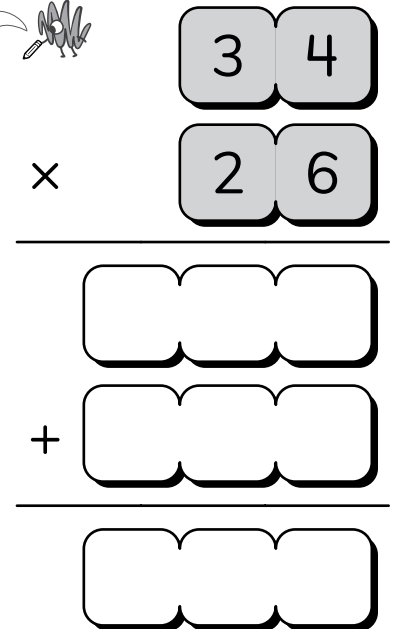
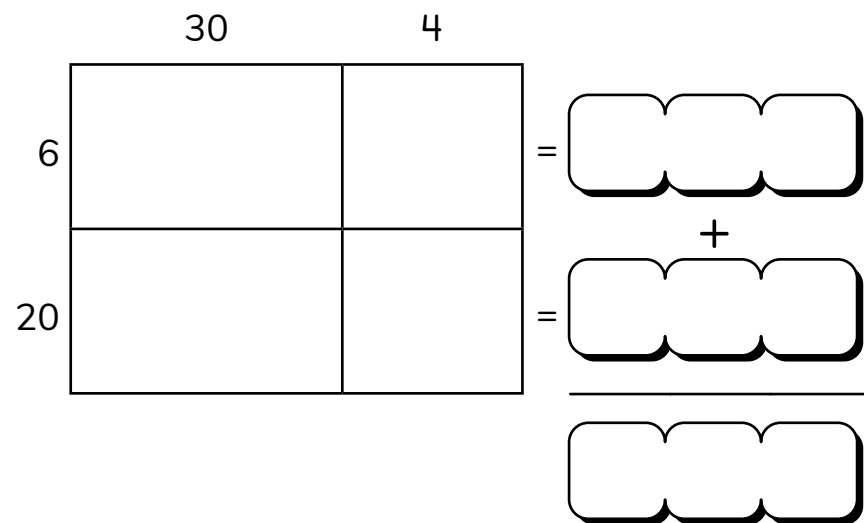

④ Which weighs more: a pumpkin weighing 4 pounds 8 ounces or a squash weighing 48 ounces? How much more?

1 pound = 16 ounces
(lb) (oz)

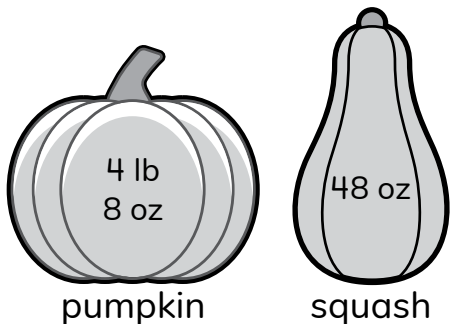

Name: _____

Date: _____



Mateo

Choosing Strategies to Multiply Two-Digit by Two-Digit Numbers

1 Solve. $798 + 989 =$

2 Use the models to show four fractions that are equivalent to $\frac{1}{2}$.

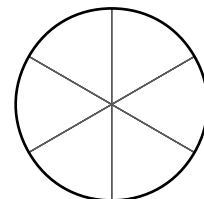
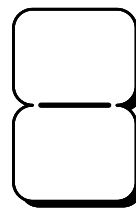
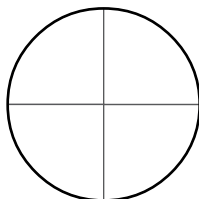
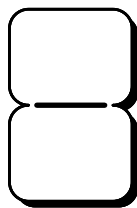

3 Circle the expressions that could be used to find the product of 24×73 .

$(20 \times 73) + (4 \times 73)$

$(2 \times 7) + (2 \times 3) + (4 \times 7) + (4 \times 3)$

$(25 \times 73) - (1 \times 73)$

$(20 \times 70) + (20 \times 3) + (4 \times 70) + (4 \times 3)$

$(20 \times 70) + (4 \times 3)$

4 Mateo helped his abuela make a hammock that was 84 inches long and 48 inches wide. What is the area of the hammock?

5 Mateo's *abuela* surprised him with a tiny hammock that is just right for his dog, Arturito! She bought Mateo 16 bags of beads for the ends of the hammock. If each bag has 36 beads, how many total beads does Mateo have? Show your thinking.

Did you show your thinking?



Name: _____

Date: _____

Choosing Strategies for Multiplication

- 1 Write an expression that represents the model.

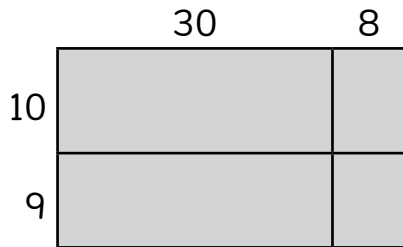

2

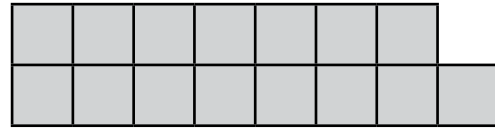

Which equations represent the model?
How do you know?

$$15 \div 2 = 7 \text{ R}1$$

$$15 = (2 \times 7) + 1$$

$$15 = 5 + 5 + 5$$

3

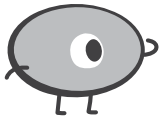

1 year = 12 months = 52 weeks = 365 days

I want to be in the critter relay race next year!
I will train for 2 hours every day for 1 year.
How many total hours will that be?

hours

4

A school set an ST Math goal of completing 1,000,000 puzzles this year. The table below lists the number of puzzles students have completed in different grades.

How many more puzzles do the students in the school still need to complete for us to reach their goal?

Grades	Puzzles
K, 1, 2	436,545
3, 4, 5	298,017

Name: _____

Date: _____



Deriving Formulas for the Perimeter of Rectangles

- ① There are 1,000 milliliters in a liter. Complete the measurement conversion.

$$45 \text{ liters} = \boxed{} \text{ milliliters}$$

- ② Label the tick marks to complete the number line.

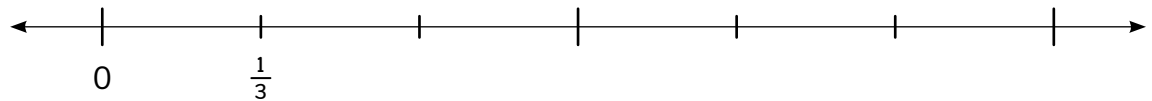

- ③ Complete the formula to find the perimeter of the rectangle.

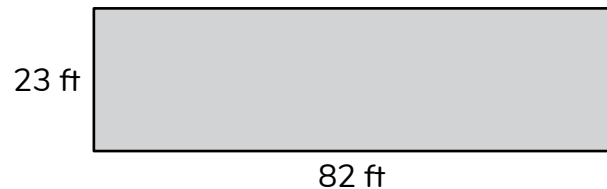

$$(2 \times \boxed{}) + (2 \times \boxed{}) = \boxed{} \text{ ft}$$

- ④ Solve. $3 \times 1,804 = \boxed{}$

- ⑤ Louis painted lines for a small basketball court in front of his basketball hoop. If the court is a 15 feet by 11 feet rectangle, what is the perimeter of the court? Explain your thinking.

Did you explain your thinking?



Name: _____

Date: _____

Finding the Perimeter and Area of Squares

- ① Solve.

$$\begin{array}{r} 2,304 \\ \times \quad 7 \\ \hline \end{array}$$

- ② Complete the equations.

$$23,000 \div \boxed{} = 23,000$$

$$23,000 \div 1,000 = \boxed{}$$

- ③ a) Use the formula to find the perimeter of the square. For this square, $s = 6$ units.

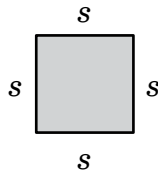

$$P = 4 \times s$$

$$P = 4 \times \boxed{}$$

$$P = \boxed{} \text{ units}$$

- b) Use the formula to find the area of the square. For this square, $s = 15$ units.

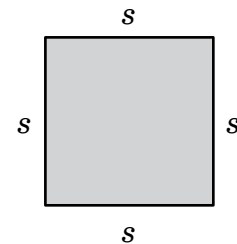

$$A = s \times s$$

$$A = \boxed{} \times \boxed{}$$

$$A = \boxed{} \text{ square units}$$

- ④ A *pho* recipe calls for 6 cups of broth. There is a 32 fl oz box of broth in the kitchen. Is there enough broth in the kitchen to make the *pho* recipe? Explain your thinking.

1 cup = 8 fluid ounces

Did you explain your thinking?



Name: _____

Date: _____

Modeling and Solving Multistep Word Problems Involving Multiplication

- 1 Is 13 grams or 13 kilograms a better estimate for the mass of a desk?

Explain your thinking.



- 2 Is 70 grams or 70 kilograms a better estimate for the mass of an apple?

Explain your thinking.



- 3 Draw a strip diagram to represent $(1,367 \times 4) - 859$.

- 4 Complete the strip diagram.

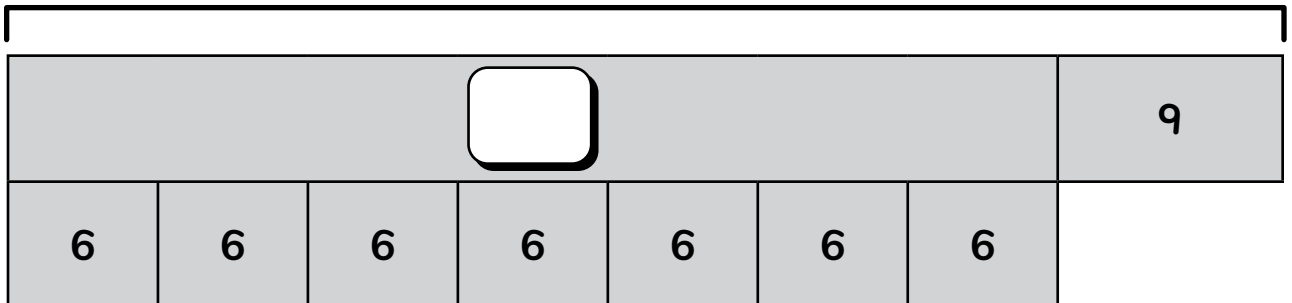
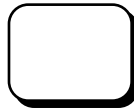

- 5 The manager of the duck pond at the carnival collected 2,488 tickets. The manager of the bean bag toss collected 3 times as many tickets as the manager of the duck pond. The manager of the balloon pop collected 1,987 fewer tickets than the manager of the bean bag toss. How many tickets were collected altogether? Show your thinking.

Did you show your thinking?



Name: _____

Date: _____



Choosing Strategies to Solve Multistep Word Problems Involving Multiplication

Mateo

- 1 Is 9 square inches or 9 square feet a better estimate for the area of a sticky note?

Explain
your thinking.



- 2 Is 84 square meters or 84 square miles a better estimate for the area of a classroom?

Explain
your thinking.



- 3 Mateo's family goes to a food truck on Saturday. They order 6 baskets of fried yuca that each cost \$5, and 3 bottles of water that each cost \$1. Mateo pays for the meal with a \$100 bill.

a) How much change will he receive?

b) Draw a strip diagram to represent the problem.

- 4 The owner of a food truck sold 312 orders of fried plantains for \$4 each and 221 orders of pupusas for \$9 each. What was the total sale price of these items in all? Show your thinking.

Did you show
your thinking?



Topic 5

Building Division Strategies

Recommended ST Math Objectives:

Multi-Digit Division

Factors and Multiples

Multi-Step Problems Using 4 Operations

Name: _____

Date: _____



Interpreting Division as Partitive or Quotitive

- ① What is the perimeter of the rectangle?

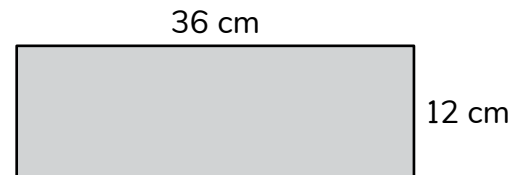

② Solve. $900 - 647 = \square$ $500 - 332 = \square$

- ③ There are 65 blocks. Each turtle gets 9 blocks and there are 2 blocks left over. How many turtles are there?

- ④ Write a division equation to represent the model.

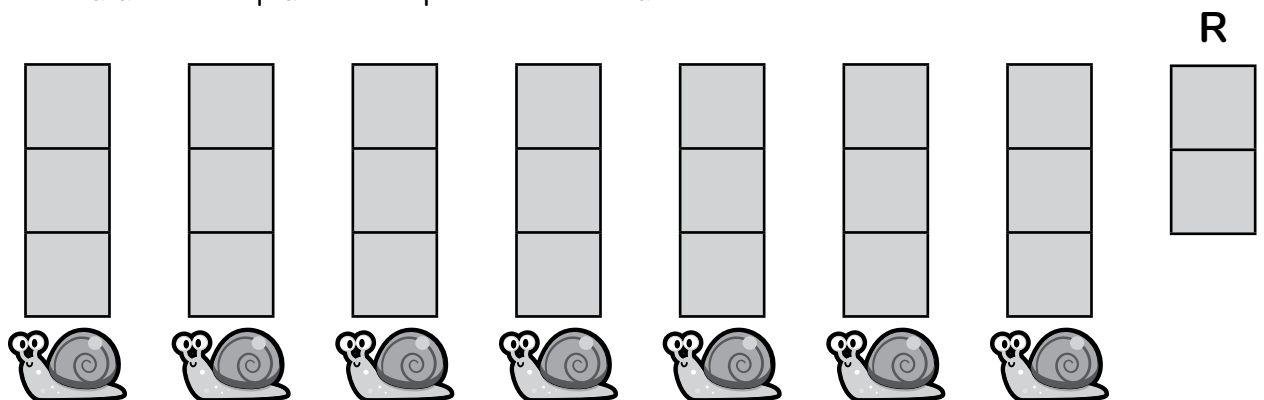

- ⑤ Mateo is cleaning up his crayons by putting them into bags. He has 51 crayons, and 8 crayons will fit in each bag. How many full bags of crayons will Mateo have? How many crayons will be left over? Explain your thinking.

Did you explain your thinking?



Name: _____

Date: _____



Representing Division with Strip Diagrams

- 1 a) Find the area of the figure.

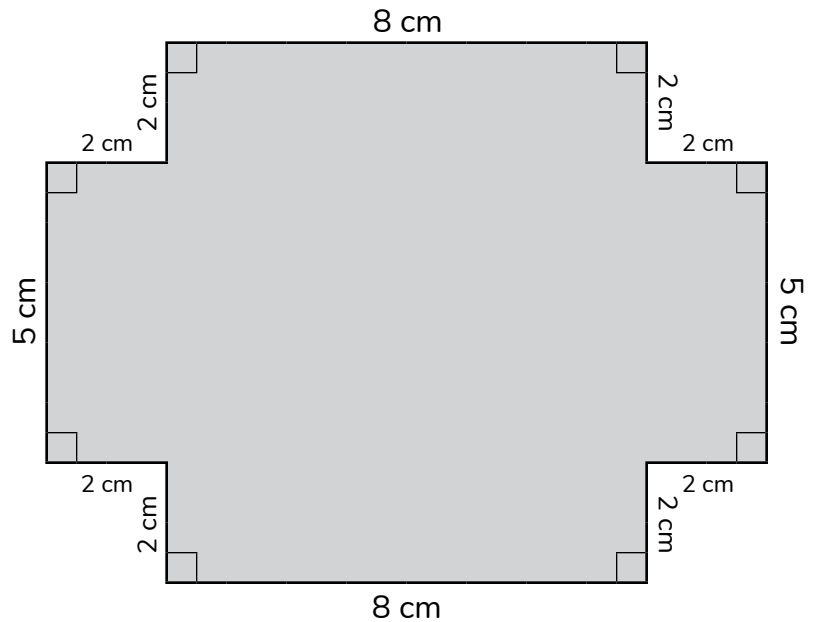

- b) How does decomposing the figure into smaller parts help when solving for area?

- 2 Aleki spent a total of 63 minutes practicing the song that he will play at a concert. If he played the song 9 times, how long is the song?

Write a division equation and draw a model to show your thinking.



- 3 For the party after his concert, Aleki made 27 bowls of snacks. If there are 4 tables, what is the greatest number of bowls Aleki can put on each table if he wants each table to have the same number of bowls?

Write a division equation and draw a model to show your thinking.



- 4 Naomi is organizing her favorite shells into new display cases. Naomi has 49 shells to display. If each display case holds 6 shells, how many display cases can Naomi fill? Explain your thinking.

Did you explain your thinking?



Name: _____

Date: _____

Modeling and Solving Division Problems on an Open Number Line

① Solve. $45 \times 6 = \square$

$52 \times 8 = \square$

② Circle the numbers that are multiples of 6. **12** **26** **36** **40**

③ Use the number line to find the value of $38 - 9 - 9 - 9 - 1$.



④ Draw a strip diagram to find the quotient of $56 \div 8$.

⑤ The P.E. teacher is organizing 44 jump ropes into boxes. Each box holds 7 jump ropes. How many jump ropes will not be in a box? Use a strip diagram to show your strategy.

Did you use a strip diagram to show your strategy?



Name: _____

Date: _____

Exploring Strategies to Solve Division Problems

- ① Complete each statement.

35 is times as much as 5.

72 is times as much as 6.

- ② Solve.

$$7 \times 8 = \text{} \quad 70 \times 8 = \text{} \quad 700 \times 8 = \text{}$$

- ③ Write an expression to represent this model.



- ④ Use the number line to find the quotient of $122 \div 5$.



- ⑤ The critters are organizing blocks into boxes. Each box is the same size, and they have 124 blocks. If the critters put 20 blocks into each box, how many boxes will they fill? Will any blocks be left over? Explain your thinking.

Did you explain your thinking?



Name: _____

Date: _____

Modeling and Solving Division Problems with Equal Groups

1 Solve for t . $t \times 9 = 81$

2 Write 3 numbers that round to 6,700 when rounded to the nearest hundred.

3 Write an equation to represent this model. $\square \div \square = \square R \square$

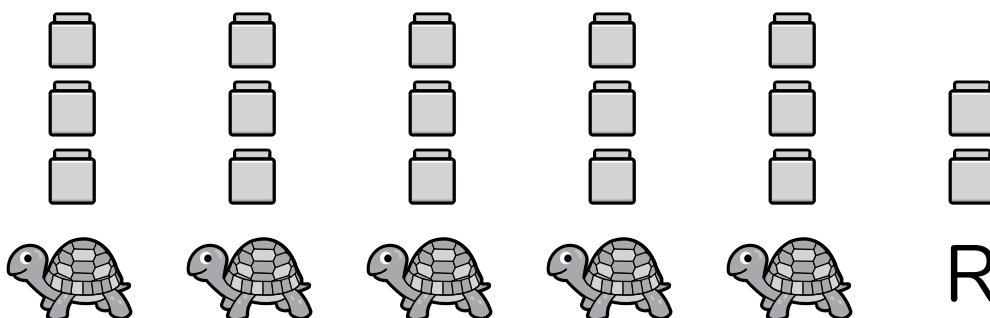

4 What will the 45th shape be?



Explain your thinking.



5 There are 75 basketball players. They need to be put on 8 equal-sized teams. How many players will be on each team? How many players will left over? Show your thinking.

Did you show your thinking?



Name: _____

Date: _____



Logan

Modeling and Solving Division Problems with Arrays

① Solve.

$$23,485 + 98,578 = \boxed{}$$

$$50,723 - 38,688 = \boxed{}$$

② a) Label the model to show how we can use it to represent $36 \div 4 = b$.

b) Use the model to find the value of b .

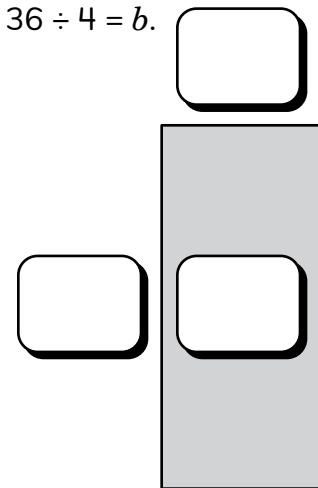

③ Logan wants to read the 84 pages of her new graphic novel in 6 days. How many pages does she need to read each day to meet her goal? Show your thinking.

Did you show your thinking?



Name: _____

Date: _____

Using Multiples and Place Value to Solve Division Problems

- 1 A rectangle has a length of 12 inches and a width of 9 inches. What is the perimeter of the rectangle?
- 2 What is the value of the underlined digit in 789,123?
- 3 Complete each statement to make it true.

is a multiple of 6. is a factor of 6.
- 4 Solve. = $24 \div 3$ = $240 \div 3$
- 5 A teacher writes $56,000 \div 7$ on the board. The teacher said knowing the factors of 56 can help the students find the quotient. Find the quotient and explain why you agree or disagree with the teacher.

Name: _____

Date: _____

Exploring Strategies to Solve Division Word Problems

- ① a) Shade in 6 parts of the rectangle. What fraction of the rectangle did you shade?



- b) Circle the fraction that is equivalent to the shaded part of the rectangle. $\frac{1}{2}$ $\frac{2}{4}$ $\frac{2}{3}$ $\frac{3}{4}$

- ② Draw a strip diagram to represent $2,800 \div 4$, and then find the quotient.

- ③ Complete each statement.

If I know $56 \div 7 = 8$, then I also know $5,600 \div 7 = \boxed{}$.

If I know $56 \div 7 = 8$, then I also know $56,000 \div 7 = \boxed{}$.

- ④ Last week, 2,800 fish were caught at the outrigger competition. An equal number of the fish were stored in each of 7 barrels. How many fish were in each barrel? Show your thinking.

Did you show your thinking?



Name: _____

Date: _____



Making Equal Groups to Divide Multidigit Numbers

- 1 A pickle company packages 23 pickles in a jar. The company is able to fill 78 jars a day.
- Estimate how many pickles will be needed to fill all of the jars in one day.
 - How many pickles will the company actually need to fill the jars?
 - How close was your estimate to the actual answer?

2 Solve. $432 \div 4 = \square$ $2,418 \div 6 = \square$

- 3 Aleki has 1,536 feet of fishing line. If he uses the same amount of fishing line for each of 3 canoes, how much fishing line will each canoe get? Show your thinking.

Did you show your thinking?



Name: _____

Date: _____



Using an Area Model to Divide Multidigit Numbers

- 1 Write 2 different equations for the total number of objects in the array.

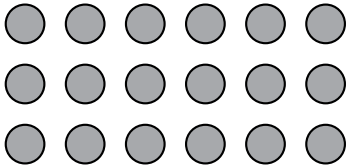

- 2 Aleki practiced the drums for 15 minutes on Friday. He practiced 3 times as long on Saturday as he did on Friday. How long did Aleki practice the drums on Saturday?

- 3 Use partial quotients to solve for the missing side length.

$$936 \div 3 = \boxed{}$$

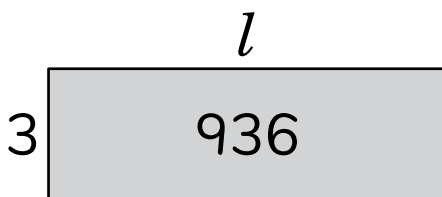

- 4 Use partial quotients to solve.

$$287 \div 7 = \boxed{}$$

- 5 A rectangle has an area of 6,448 square feet. If the width of the rectangle is 8 feet, what is the length? Show your thinking.

Did you explain your thinking?



Name: _____

Date: _____

Partitioning Area Models in Different Ways to Divide Multidigit Numbers

- ① What is $500,000 + 80,000 + 3,000 + 200 + 5$ in standard form?

- ② Use the correct symbol to make this statement true. Use $<$, $>$, or $=$.

$$34,398 \bigcirc 34,893$$

- ③ Write a division equation to match the model and find the value of l .

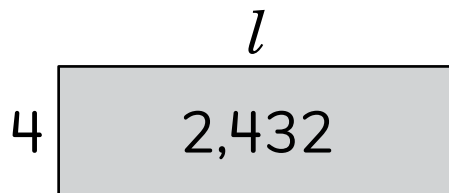

- ④ Write a division equation to match the model.

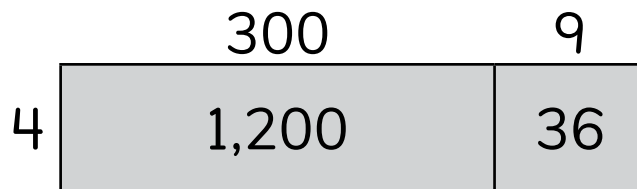

- ⑤ The park will have a new dog run that will be 6 yards wide and in the shape of a rectangle. The perimeter of the dog run will be made of sections of fence that are 1 yard long. If there are 164 sections of fence, how long can the dog run be in yards? Explain your thinking.

Did you explain your thinking?



Name: _____

Date: _____

Regrouping by Place Value to Divide Multidigit Numbers

- ① Label each tick mark on the number line.

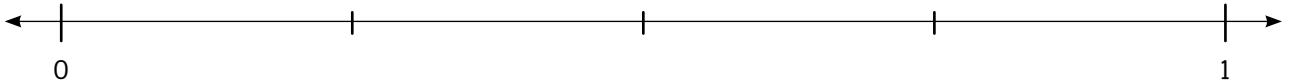

- ② A movie begins at 1:20 p.m. The movie is 120 minutes long. At what time will the movie end?

- ③ Draw a model with tens and ones to solve the equation $137 \div 4 = q$.

- ④ Draw a model with tens and ones to solve the equation $256 \div 7 = q$.

- ⑤ A theater with 244 seats is giving away tickets to a play. If the theater wants to give an equal number of tickets to 8 different classes, how many tickets will each class get? How many tickets will be left over? Explain your thinking.

Did you explain your thinking?



Name: _____

Date: _____



Building Area Models to Divide Multidigit Numbers

- 1 Complete each statement.

264,894 rounded to the nearest 10,000 is

264,894 rounded to the nearest 100,000 is

- 2 Solve.

$$8,762 + 746 =$$

- 3 Complete the model to find the quotient of $432 \div 6$.

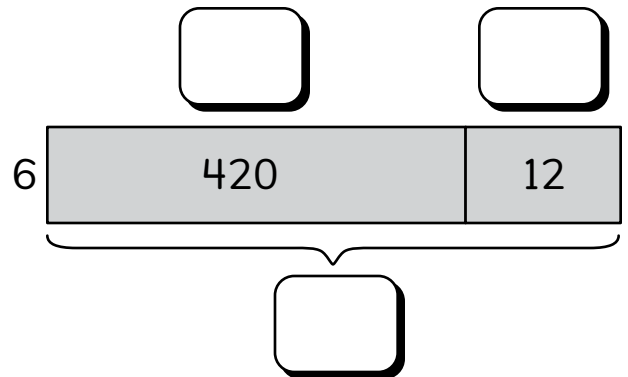

- 4 What division equation does this model represent?

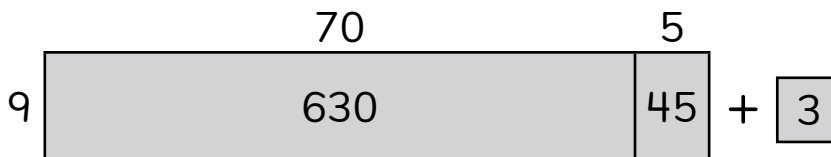

- 5 Aleki bought a storage box for some of his old-fashioned records that he uses to listen to music. The rectangular bottom of the storage box has an area of 126 square inches. If the width of the storage box is 9 inches, what is the length? Show your thinking.

Did you show your thinking?



Name: _____

Date: _____

Exploring Written Methods to Divide Multidigit Numbers

① Solve. $93,045 - 4,983 =$

② There are 6 boxes. Each box has 9 paper clips in it. How many paper clips are there in all?

③ Use vertical partial quotients to find the value of $428 \div 3$.

④ What is the quotient of $5,224 \div 8$?

	R
$3 \overline{) 428}$	$3 \times$ <input style="width: 40px; height: 30px;" type="text"/>
	$3 \times$ <input style="width: 40px; height: 30px;" type="text"/>
	$3 \times$ <input style="width: 40px; height: 30px;" type="text"/>

⑤ The park manager had 216 workers volunteer to clean up the park. The workers were divided into 5 equal teams to handle different tasks. How many workers were on each team? Were all workers on a team? Explain your thinking.

Did you explain your thinking?



Name: _____

Date: _____

Comparing Written Methods to Divide Multidigit Numbers

① The rule for this pattern is add 4.

a) Write the next 3 numbers. 3, 7, 11, , ,

b) A student said that every number will be a prime number. Is the student correct?

Explain your answer.



② a) Create a pattern.

, , ,

b) The rule is

③ Complete the equation to represent this model.

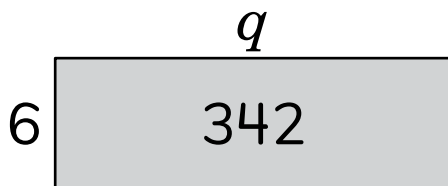

\div =

④ Solve.

$$472 \div 5 = \text{$$

⑤ The park manager asked 528 volunteers to help with the annual songbird count. The volunteers were divided up into 7 equal teams to count birds in the park. How many volunteers were on each team? Were all volunteers on a team? Show your thinking.

Did you explain your thinking?



Topic 6

Extending Division Strategies

Recommended ST Math Objectives:

Multi-Digit Division

Multi-Step Problems Using 4 Operations

Factors and Multiples

Name: _____

Date: _____

Identifying Common Multiples and Factors

- ① What is the area of the figure?

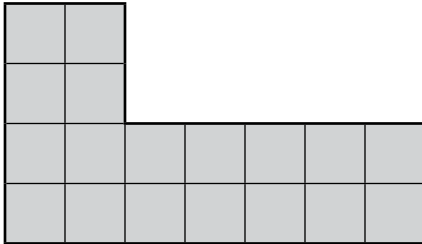

- ② Draw a rectangle.

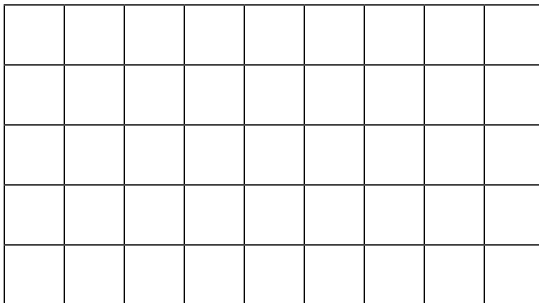

- ③ List the first 5 multiples of each number: 6 and 12.

- ④ Use the T-chart to organize the factor pairs of 48.

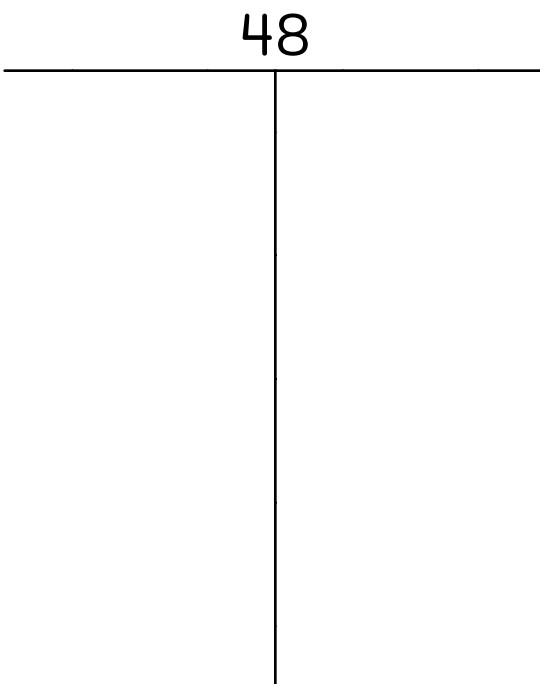

- ⑤ A chef is baking a chocolate cake. The chef has 24 raspberries to place in an array on top of the cake. What are all of the arrays that could be used to arrange the raspberries?

Name: _____

Date: _____



Doubling and Halving to Find Factor Pairs

- ① Partition the circle into sixths.
Shade in $\frac{4}{6}$.

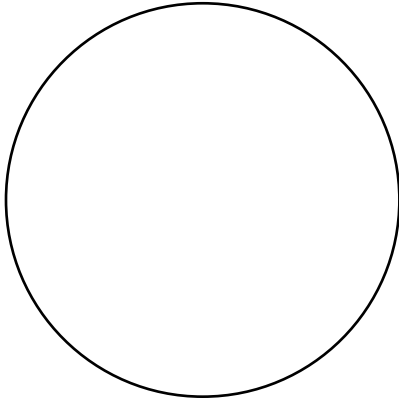

- ② What fraction is equivalent to $\frac{4}{6}$?

- ③ Use the doubling and halving strategy to find the product of 16×8 .

- ④ List all the factor pairs for 54.

- ⑤ Aleki is setting up for the school band performance. What are all of the different ways he could arrange 112 chairs in a rectangular array? Which way do you think is best? Explain your thinking.

Did you explain
your thinking?



Name: _____

Date: _____



Exploring Factors and Multiples

1 Complete each statement.

is 10 times as much as 90.

is 100 times as much as 90.

2 What is $200,000 + 30,000 + 500 + 60$ in standard form?

3 All factors of even numbers are even.

a) Do you think this is true or false?

b) Give 3 examples to support your thinking.

4 What are 2 common multiples of 4 and 6?

5 Aleki's uncle is hosting a cookout for 60 people. Hot dogs come in packages of 8. Hot dog buns come in packages of 12. Aleki's uncle needs at least 1 hot dog and 1 bun per person. He wants to have the same number of hot dogs and hot dog buns. How many packages of hot dogs and how many packages of hot dog buns should Aleki's uncle buy? Explain your thinking.

Did you explain your thinking?



Name: _____

Date: _____



Hannah

Using Length Models to Find Factors and Multiples

- ① Estimate the sum of $65,873 + 23,782$ by rounding the addends to the nearest 1,000.

② Find the sum. $65,873 + 23,782 =$

- ③ Complete the strip diagram to show division into equal parts.

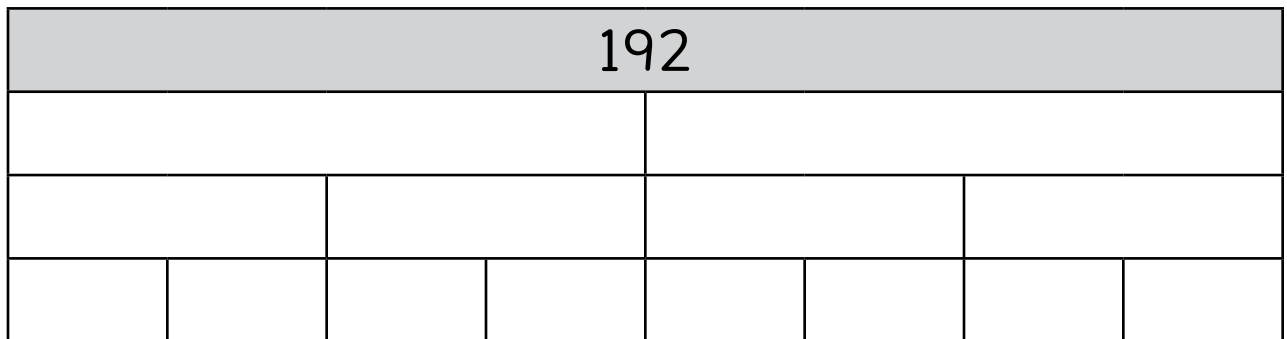

- ④ 42 is a multiple of this machine. Show what the pattern could be and complete the equation.

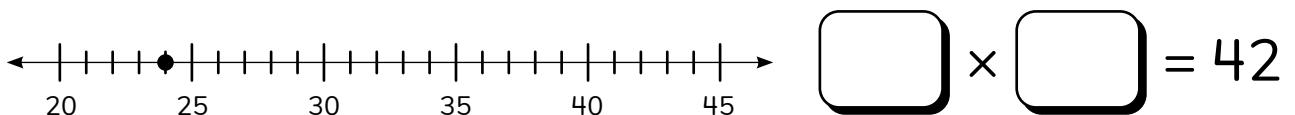

- ⑤ Hannah's dad wants to plant 60 pumpkin seeds. The seeds come in packs of 4, 5, or 9. Which size pack should Hannah's dad buy to have exactly 60 seeds? How many of that pack? Explain your thinking.

Did you explain your thinking?



Name: _____

Date: _____



Candace

Representing the Standard Division Algorithm with Base Ten Models

- 1 Draw an area model, and then solve.

$$27 \times 34 = \boxed{}$$

- 2 Write a factor pair that represents the dimensions of the rectangle.

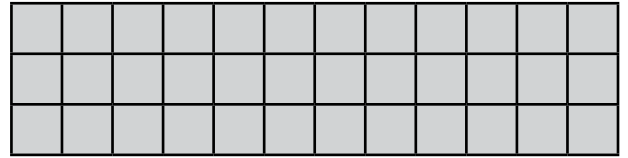

$$\boxed{} \times \boxed{}$$

- 3  Find the quotient using the standard algorithm.

$$\begin{array}{r} \\ 5 \overline{) 607} \\ - \\ \hline \\ - \\ \hline \\ - \\ \hline \\ - \\ \hline \\ - \\ \hline \\ - \\ \hline \end{array} \quad \begin{array}{l} \boxed{} \\ \boxed{} \\ \boxed{} \\ \boxed{} \end{array}$$

- 4 Candace wants a new pair of soccer cleats that cost \$56. She earns \$7 every week for helping with chores and yard work. How long will it take Candace to save enough money to buy the new soccer cleats?

Name: _____

Date: _____

Representing the Standard Division Algorithm with Area Models

- 1 Use horizontal partial products to solve.

$$\begin{aligned} 9 \times 37 &= \boxed{} \times (\boxed{} + \boxed{}) \\ &= (\boxed{} \times \boxed{}) + (\boxed{} \times \boxed{}) \\ &= \boxed{} + \boxed{} \\ &= \boxed{} \end{aligned}$$

- 2  Divide using an area model and the standard algorithm.

$$2 \overline{) 8,350}$$

	Thousands	Hundreds	Tens	Ones
2	<input type="text"/>	<input type="text"/>	<input type="text"/>	<input type="text"/>

- 3 The seat of the chair measures 1' 2" off the ground. The desk is twice as tall as the height of the chair seat. How tall is the desk, in inches?

1 foot = 12 inches

Name: _____

Date: _____

Dividing with the Standard Algorithm

- ① Place the numbers on the number line in order from least to greatest. 46,001 4,798 43,563



- ② a) Use the data to complete the frequency table.
28, 30, 47, 44, 51, 15, 32,
30, 36, 49, 24, 55, 37

Number of Minutes
Students Read Yesterday

Time Spent Reading (minutes)	Number of Students
10–19	
20–29	
30–39	
40–49	
50–59	

- ③ Find each quotient using the standard algorithm for division.

a) $7 \overline{) 3,268}$

b) $4 \overline{) 4,080}$

- b) What is the most common amount of time spent reading?
- ⑤ If a squirrel collects about 25 acorns in 1 hour, about how many acorns does the squirrel collect in 12 hours? Show how you know.

Name: _____

Date: _____



Solving Problems with Multiplication and Division

- ① Solve using the standard algorithm.

$$\begin{array}{r} 7,392 \\ + 608 \\ \hline \end{array}$$

- ② Find the quotient using the standard algorithm.

$$4 \overline{)296}$$

- ③ Wayfinders completed a journey of 1,323 nautical miles in 9 days and sailed the same distance each day. How many nautical miles did the wayfinders sail each day?

- ④ Aleki and his uncle went on a 4 mile hike while they were in Samoa. How far did they hike in yards? Show your thinking with an equation.

1 mile = 1,760 yards

Did you show your thinking with an equation?



Name: _____

Date: _____

Modeling and Solving Multistep Word Problems Involving Division

① Estimate the difference of $45,808 - 14,345$ to the nearest 1,000.

② Find the difference. $45,808 - 14,345 =$

③ List all of the factor pairs for 64.

④ Solve.

$$1,608 \div 6 = \text{$$

$$1,308 \div 4 = \text{$$

⑤ There are a total of 4,088 beads in a shipment. The beads are packaged into 8 equal bags. How many beads are in each bag? Show your thinking.

Did you show your thinking?



Topic 7

Extending Addition and Subtraction to Fractions

Recommended ST Math Objectives:

Adding and Subtracting Fractions

Mixed Numbers

Fractions - Equivalence and Ordering

Name: _____

Date: _____



Dani

Introducing Fractions Greater Than 1 as a Sum of Unit Fractions

- 1 Circle all the equations that can be used to represent the model.

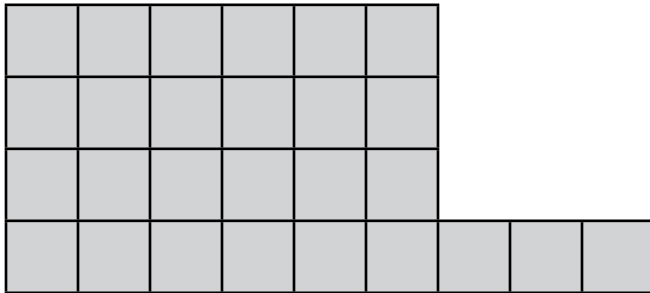

$$27 \div 4 = 6 \text{ R}3$$

$$24 \div 4 = 6$$

$$27 = (4 \times 6) + 3$$

$$(6 \times 4) + 3 = 27$$

- 2 List all the factor pairs of 48.

- 3 What number does this model represent? Compose the number with unit fractions.

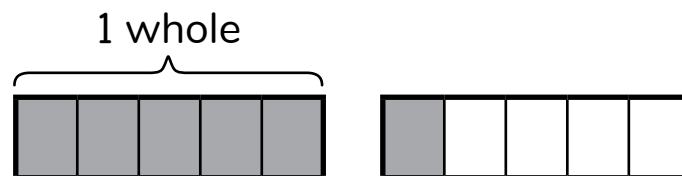

$$\frac{\quad}{\quad} + \frac{\quad}{\quad} + \frac{\quad}{\quad} + \frac{\quad}{\quad} + \frac{\quad}{\quad} + \frac{\quad}{\quad} = \frac{\quad}{\quad}$$

- 4 Dani is 4'4" tall and her teacher is 5'3" tall.
How many inches taller is Dani's teacher than Dani?

1 foot = 12 inches

Name: _____

Date: _____



Exploring Fractions Greater Than 1 on a Number Line

① Write the number in standard form. $(8 \times 100,000) + (5 \times 1,000)$

② What is the product of $376,000 \times 100$?

③ a) Where is Jiji?

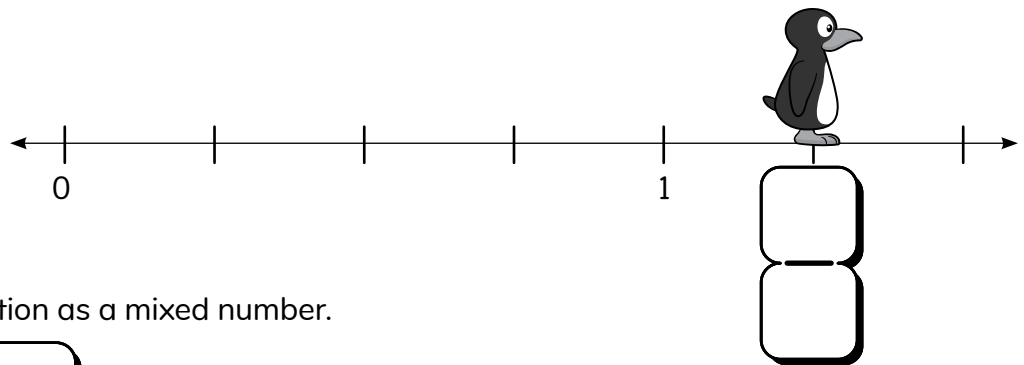

b) Write Jiji's location as a mixed number.

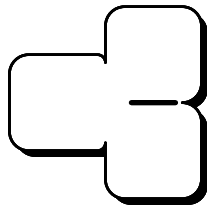

④ Mateo's Art Club has \$250 to spend on art supplies. The Art Club bought 5 packs of paintbrushes for \$13 each and \$145 worth of paint. How much money does the Art Club have left for other supplies?

Name: _____

Date: _____



Mateo

Identifying Fractions as Mixed and Whole Numbers

- ① Find the perimeter and the area of the following rectangle.

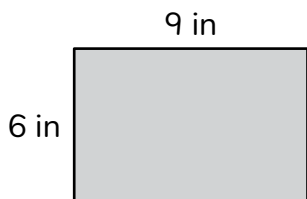

$A =$

$P =$

- ② Which measurement most likely describes the weight of a soccer ball?

14 pounds

14 fluid ounces

14 ounces

14 kilograms

- ③ a) Where is Jiji? Write your answer as a fraction and as a mixed number.

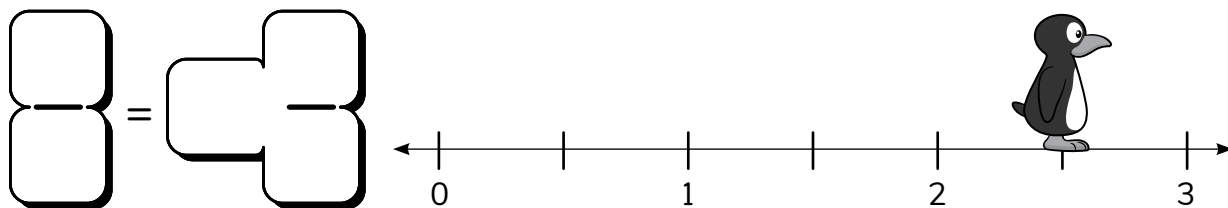

- b) Draw a point at $\frac{2}{2}$ on the number line above.

- ④ Mateo is painting a mural. He has 3 gallons of blue paint, 4 quarts of orange paint, and 2 quarts each of red paint and yellow paint. How much paint does Mateo have for his mural?

1 gallon (gal) = 4 quarts (qt)

Name: _____

Date: _____

Partitioning and Iterating Fractions to Compose New Fractions

- ① What number does the model represent? Compose the number with unit fractions.

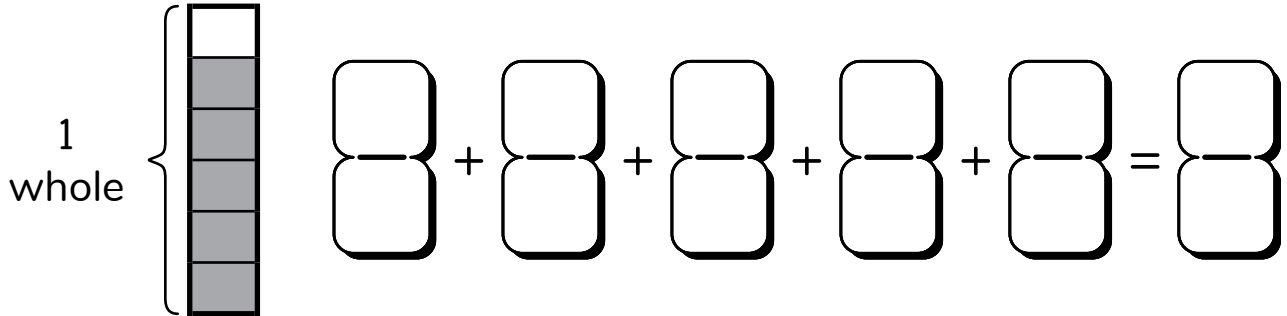

- ② What is the area of the square?

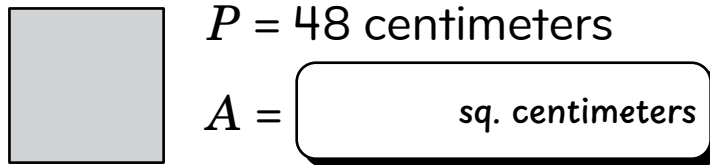

- ③ This bar is $\frac{6}{4}$.
-
- If we wanted to show 1, would it be longer or shorter than this bar? Explain your thinking.

Did you explain your thinking?

- ④ This bar is $\frac{1}{3}$.
-
- If we wanted to show 1, would it be longer or shorter than this bar? Explain your thinking.

Did you explain your thinking?

Name: _____

Date: _____



Mateo

Using Bar Models to Decompose Numbers into Sums of Fractions

- 1 a) How many more squares were drawn than stars and circles?
b) How many shapes were drawn in all?

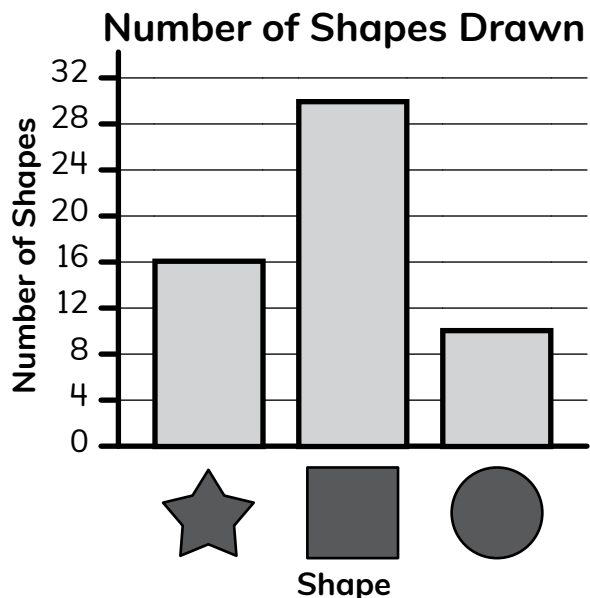

- 2 How can you decompose $\frac{7}{4}$ into 2 fractions?



$$\frac{3}{4} + \frac{3}{4} = \frac{7}{4}$$

- 3 What is the missing addend? Draw a bar model to show your thinking.

$$\frac{3}{4} + \frac{\quad}{4} + \frac{7}{4} = 3$$

- 4 Mateo bought a package of sculpting clay. The whole package was divided into sixths. How can Mateo break apart the clay into 2 fractions with sixths in the denominator to store it? Draw a picture to explain your thinking.

Did you draw a picture to explain your thinking?



Name: _____

Date: _____



Logan

Using Number Lines to Decompose Numbers into Sums of Fractions

- ① Complete the table.

16 oz	oz	oz	oz	oz
1 lb	2 lb	3 lb	4 lb	5 lb

- ② How many pounds are equivalent to 240 ounces of cheese?

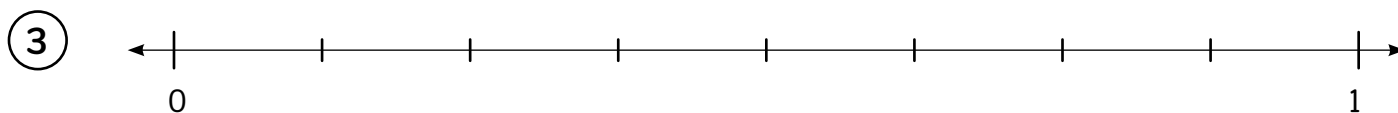

This number line is partitioned into

fourths. fifths. sixths. eighths.

- ④ Show 2 jumps on the number line to make $1\frac{1}{4}$. Write an equation to represent the model.



- ⑤ Logan ran before and after school. She ran a total of $2\frac{3}{4}$ miles. What are 2 different ways she could have broken up the run? Show your thinking by drawing a model and writing an equation.

Did you show your thinking?



Name: _____

Date: _____



Sarah

Connecting Fractions on a Number Line to Rulers and Dot Plots

1 Draw an array to show $16 \div 4$.

2 Is this equation true or false? $56 \div 7 = 64 \div 8$

Explain your thinking.



3 Find the length of the pencil.

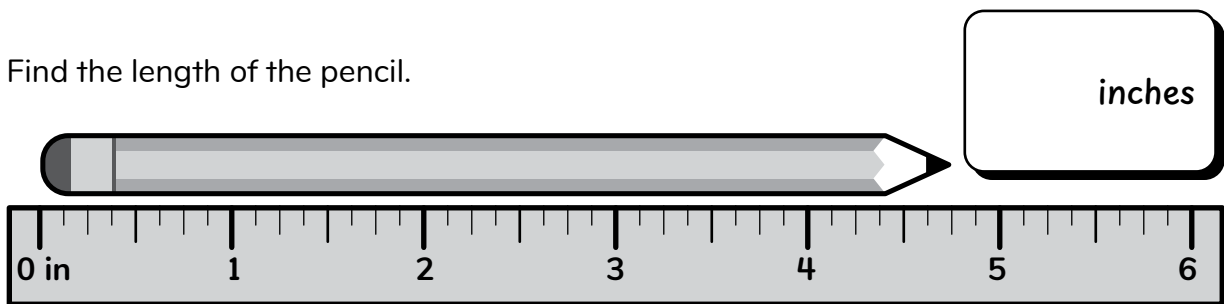

4 How many of the classroom objects have a length of $4\frac{1}{4}$ inches?

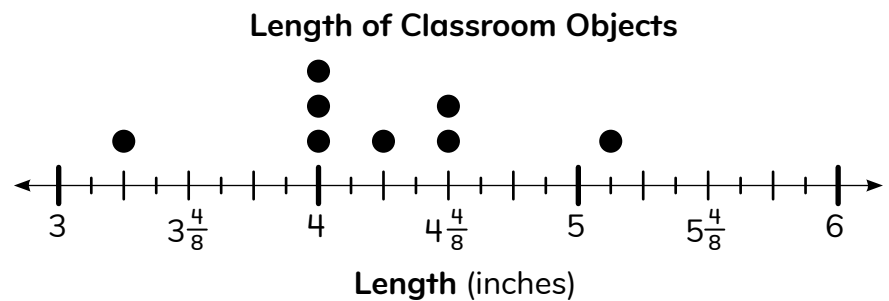

5 Sarah and her dad are cutting wood to make planting boxes for their garden. Sarah measures a piece of wood and says it is $8\frac{1}{2}$ inches long. Her dad measures it and says it is $8\frac{4}{8}$ inches long. Are their measurements the same? Explain your thinking.

Did you explain your thinking?



Name: _____

Date: _____



Using Bar Models to Add and Subtract Fractions with Common Denominators

Louis

- 1 a) Find the area of the figure.

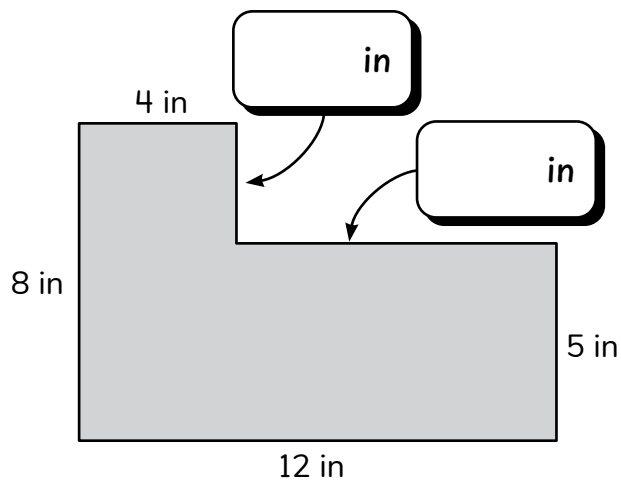

- b) Find the perimeter of the figure.

- 2 Use the bar models to find the value of $\frac{3}{8} + \frac{7}{8}$.

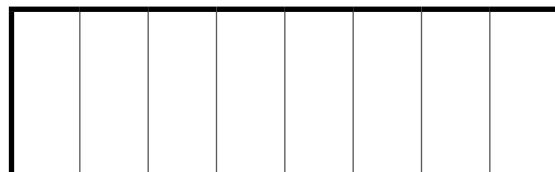
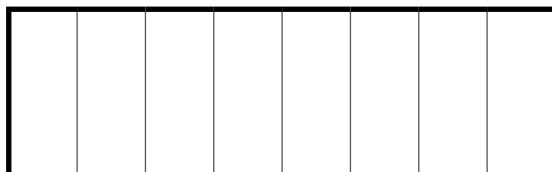

- 3 Draw a bar model to model and find the value of $\frac{4}{3} - \frac{2}{3}$.

- 4 Louis and his dad made a big batch of soup. They used $\frac{4}{6}$ cup of kidney beans and $\frac{5}{6}$ cup of red beans. What is the total amount of beans they used in the soup?
Draw a bar model to explain your thinking.

Did you draw a model to explain your thinking?



Name: _____

Date: _____

Using Number Lines to Add and Subtract Fractions with Common Denominators

- ① Circle the expression that has a quotient of about 8.

$$8 \div 3$$

$$34 \div 8$$

$$49 \div 6$$

$$13 \div 5$$

- ② What rule can be used to find the output number when the input number is given?

Input	Output
10	20
15	25
20	30
35	45

Rule: ○ □

- ③ Use the number line to solve.

a) $\frac{5}{2} - \frac{3}{2} =$ □

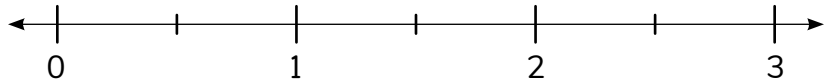

b) $\frac{5}{8} + \frac{2}{8} =$ □

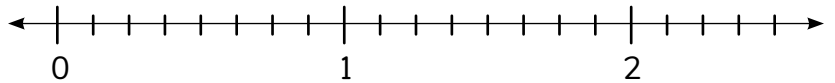

- ④ Jiji biked $\frac{9}{10}$ km. Paco biked $\frac{7}{10}$ km. How much farther did Jiji bike than Paco? Show your thinking with an equation.

Did you show your thinking with an equation?



Name: _____

Date: _____



Dani

Solving Problems with Fractions of Sets

- 1 Write 2 equations for finding the perimeter of the rectangle.

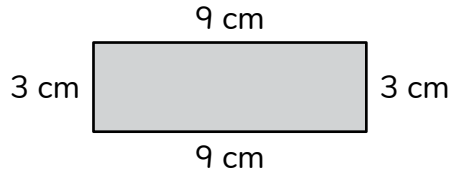

- 2 Complete the statement. **795,630**

The digit 9 in the number above has a value of $9 \times$

- 3 a) What fraction of the backpacks are blue or green? Write an equation to explain your thinking.

Number of Backpacks by Color

Green	
Blue	
Red	

- b) What fraction of the backpacks are not blue? Write an equation to explain your thinking.

Each means 1 backpack.

- 4 Dani is helping to set up for a family party. She has 42 flowers and will put 7 flowers in each vase. How many vases does she need? Write an equation to show how your thinking.

Did you write an equation to show your thinking?



Name: _____

Date: _____

Solving Word Problems with Fractions

- ① What number could represent the triangle?

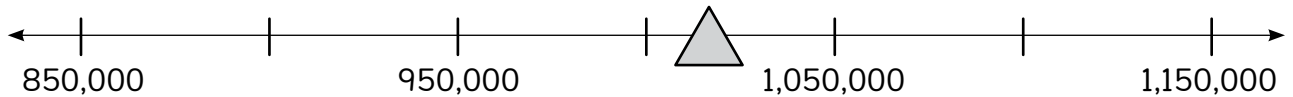

- ② Draw a bar model and solve.

$$\frac{9}{5} + \frac{5}{5} =$$

- ③ To prepare for the *Wacipi*, Grass Dancers decorate their outfits with long fringe to represent prairie grass swaying in the wind. One Grass Dancer decided to have 12 bunches of fringe for his regalia. He prepared $\frac{4}{12}$ of the total fringe on Monday and another $\frac{5}{12}$ of the total fringe on Tuesday. What fraction of the fringe bunches does the dancer still need to prepare?

Use f to represent the unknown information.

Name: _____

Date: _____



Adding Fractions and Mixed Numbers with Common Denominators

- ① Solve.

$$642 \times 6 = \boxed{}$$

$$398 \times 3 = \boxed{}$$

- ② Complete each statement.

a) 48 is times as much as 6.

b) 80 is times as much as 5.

- ③ Use the number line to find the value of $2\frac{1}{4} + \frac{5}{4}$.

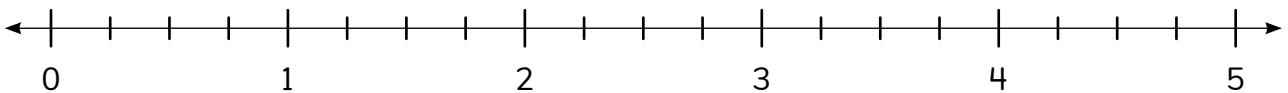

- ④ Find the value of $\frac{5}{3} + 2\frac{2}{3}$ using a bar model or number line.

- ⑤ Sarah and her dad use $2\frac{4}{6}$ bags of soil to fill the vegetable beds in their garden. They use $\frac{8}{6}$ bags of soil to fill the flower beds. What is the total amount of soil they use? Show your thinking.

Did you show your thinking?



Name: _____

Date: _____



Dani

Subtracting Fractions and Mixed Numbers with Common Denominators

① Solve. $56 \div d = 7$

$64 \div m = 8$

$d = \boxed{}$

$m = \boxed{}$

- ② A runner was training for a race. On Saturday, she ran 7 miles. She ran 6 times as far during the next week as she did on Saturday. How far did she run during the next week?

Show your thinking.



- ③ Circle the numbers or expressions that are equivalent to $\frac{14}{3}$.

$\frac{3}{3} + \frac{3}{3} + \frac{3}{3} + \frac{3}{3} + \frac{2}{3}$

$1 + \frac{3}{3} + \frac{1}{3}$

$4\frac{2}{3}$

$\frac{7}{3} + \frac{3}{3} + \frac{2}{3}$

- ④ Use a number line or bar model to find the value of $\frac{11}{4} - 1\frac{2}{4}$.

- ⑤ Dani had $\frac{18}{6}$ bags of fry bread. She used $1\frac{2}{6}$ bags with the *wojapi* she made. How much fry bread is left? Show your thinking.

Did you show your thinking?



Name: _____

Date: _____



Adding Mixed Numbers with Common Denominators

- ① What is the value of the underlined digit in $3\underline{4}5,218,907$?
- ② The first number in the pattern is 34. The rule is to add 14. Write the first 4 numbers in the pattern.
- ③ a) Convert $\frac{21}{8}$ to a mixed number.
- b) Convert $\frac{14}{4}$ to a mixed number.
- c) Convert $\frac{25}{6}$ to a mixed number.
- ④ Solve.
- $$2\frac{3}{5} + 4\frac{4}{5} = \boxed{}$$
- $$1\frac{1}{6} + 3\frac{5}{6} = \boxed{}$$
- ⑤ Dani and her brother built shelves for the local library. They used $1\frac{4}{8}$ boxes of nails for one shelf and $1\frac{6}{8}$ boxes of nails for another shelf. How many boxes of nails did they use altogether? Show your thinking.

Did you show your thinking?



Name: _____

Date: _____



Subtracting Mixed Numbers with Common Denominators

- 1 Complete each statement.

is 10 times as much as 300.

is 100 times as much as 300.

- 2 A teacher wants to buy stickers for 104 fifth-grade students so they can decorate their notebooks. The teacher wants each student to have 6 stickers. Packages come with 10 stickers each. How many packages does the teacher need to buy to make sure every student has enough stickers?

Show your thinking.



- 3 Solve.

$$3\frac{3}{5} - 2\frac{4}{5} = \boxed{}$$

$$4\frac{1}{3} - 1\frac{2}{3} = \boxed{}$$

$$5\frac{2}{4} - 2\frac{3}{4} = \boxed{}$$

- 4 Louis has $3\frac{3}{4}$ pounds of flour that he wants to use to make muffins. The recipe calls for $1\frac{1}{4}$ pounds of flour. How much flour will Louis have left? Show your thinking.

Did you show your thinking?



Name: _____

Date: _____



Candace

Using Dot Plots to Solve Mixed Number Addition and Subtraction Problems

1 Write 1,000,000,000 in expanded notation.

2 Use $<$, $>$, or $=$ to compare. $1,000,000,000$  $1,000,000$

3 Candace recorded the distances that she kicked a soccer ball.

a) Using the data listed in the table, create a dot plot.

Distance (yards)				
3	$3\frac{1}{8}$	$3\frac{5}{8}$	$4\frac{4}{8}$	$4\frac{2}{4}$
$4\frac{3}{8}$	$4\frac{1}{2}$	$3\frac{7}{8}$	$3\frac{5}{8}$	$4\frac{1}{4}$

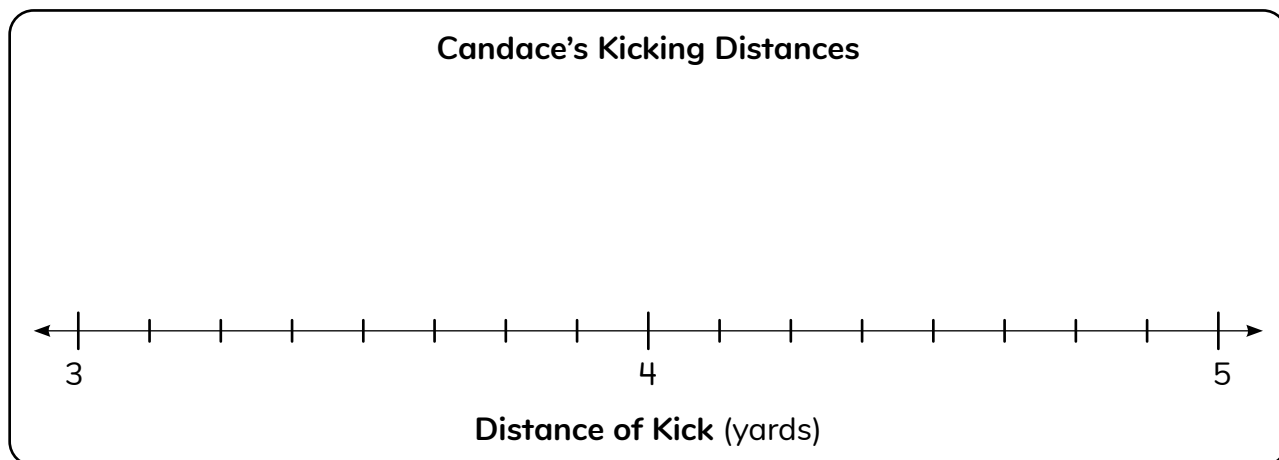

b) Based on the data she collected, how many times did Candace kick the soccer ball at least $4\frac{1}{4}$ yards?

Topic 8

Exploring Fraction Thinking and Discovering Decimals

Recommended ST Math Objectives:

Fractions - Equivalence and Ordering

Fraction and Decimal Equivalence

Mixed Numbers

Name: _____

Date: _____



Brian

Using Fraction Strips to Explore Equivalent Fractions

① Solve. $\square = 5,628 \div 6$ $\square = 3,424 \div 4$

② Name 2 sets of equivalent fractions that these number lines show.

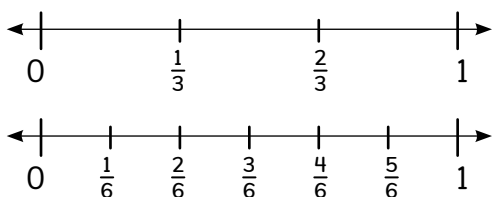

③ Complete the table.

1 whole	$\frac{1}{1}$	$\frac{\square}{4}$	$\frac{\square}{8}$	$\frac{\square}{12}$
2 wholes	$\frac{2}{1}$	$\frac{\square}{4}$	$\frac{\square}{8}$	$\frac{\square}{12}$
3 wholes	$\frac{3}{1}$	$\frac{\square}{4}$	$\frac{\square}{8}$	$\frac{\square}{12}$
10 wholes	$\frac{10}{1}$	$\frac{\square}{4}$	$\frac{\square}{8}$	$\frac{\square}{12}$

④ Is $\frac{3}{4}$ equivalent to $\frac{5}{8}$? Explain your thinking.

⑤ Brian is baking with his grandpa. They need to measure out $\frac{1}{4}$ cup of raisins. Brian only has the $\frac{1}{8}$ measuring cup. Is Brian able to measure $\frac{1}{4}$ cup of raisins? Explain your thinking.

Did you explain your thinking?



Name: _____

Date: _____

Using Bar Models to Make Equivalent Fractions

1 a) Estimate the difference of $4,006 - 2,387$.

b) Find the actual difference of $4,006 - 2,387$.

2 Write an equation to represent the equivalent fractions in the bar model.

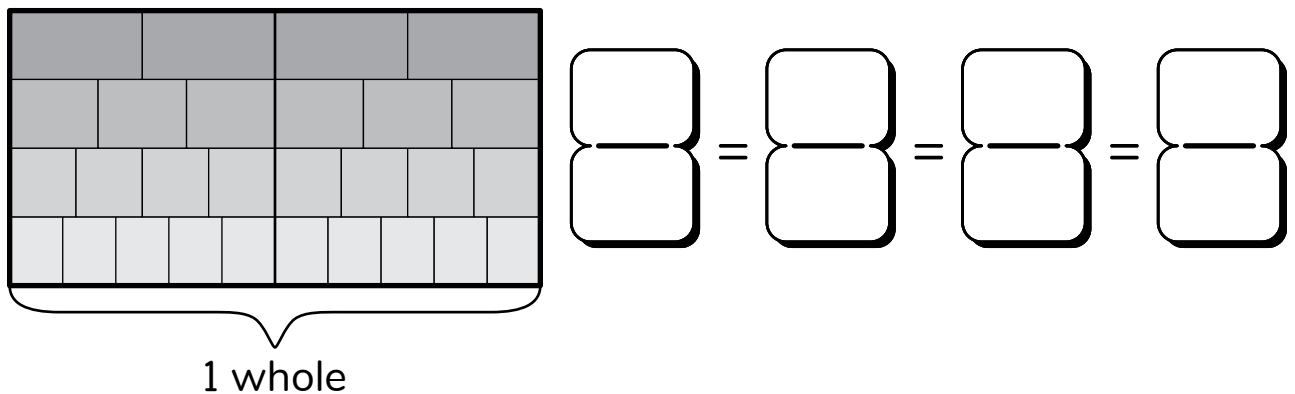

3 Is $\frac{12}{5}$ equivalent to $\frac{24}{10}$? Explain your thinking. 

4 A critter folded a piece of paper into 5 equal sections. If the critter wants to color $\frac{4}{10}$ of the paper's sections red, how many of the sections should the critter color? Draw a picture to show your thinking.

Did you draw a picture to explain your thinking?

Name: _____

Date: _____



Using Multiplication to Make Equivalent Fractions

- 1 Complete the equation.

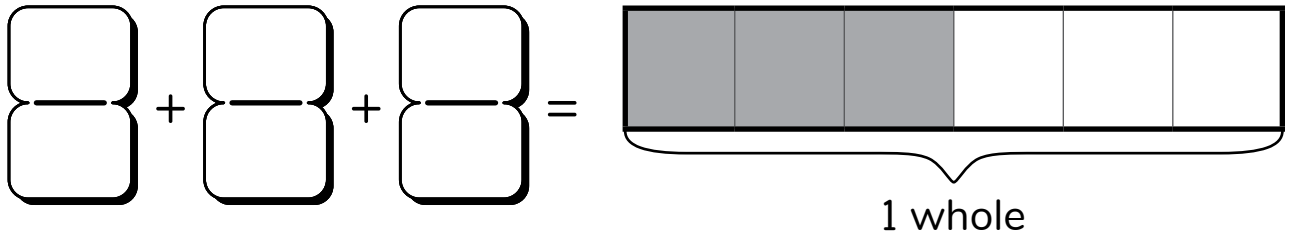

2 Solve. $\square = 98 \times 23$

$\square = 76 \times 88$

- 3 Find an equivalent fraction.

$$\frac{(3 \times \square)}{(4 \times \square)} = \frac{\square}{12}$$

- 4 Find an equivalent fraction.

$$\frac{(5 \times \square)}{(2 \times \square)} = \frac{\square}{10}$$

- 5 Sarah told Logan that she knows a fraction is equivalent to 1 if the numerator and the denominator are the same number. Do you agree with Sarah? Explain your thinking.

Did you explain your thinking?



Name: _____

Date: _____



Logan

Using Multiplicative Relationships to Identify Equivalent Fractions

- ① Find the quotient using the standard algorithm.

$$6 \overline{) 3,618}$$

- ② Solve.

$$\begin{array}{r} 9,325 \\ - 728 \\ \hline \end{array}$$

- ③ Create your own fraction and compare it to the benchmark fraction $\frac{1}{2}$.

18

○

1/2

- ④ Logan ran $\frac{7}{8}$ mile on Saturday and $\frac{5}{8}$ mile on Sunday.
How far did Logan run during both days? Explain your thinking.

Did you explain your thinking?



Name: _____

Date: _____



Using Division to Make Equivalent Fractions

1 Complete each statement.

a) 81 is times as much as 9.

b) 63 is times as much as 9.

2 What is the value of the underlined digit in 983,256?

3 Find an equivalent fraction.

$$\frac{(6 \div \boxed{})}{(8 \div \boxed{})} = \frac{\boxed{}}{\boxed{4}}$$

4 Find an equivalent fraction.

$$\frac{(4 \div \boxed{})}{(12 \div \boxed{})} = \frac{\boxed{}}{\boxed{3}}$$

5 Louis folded a strip of paper into 3 equal parts. He got a new strip of paper and folded it so that he could make fraction pieces that are equivalent to thirds. Did Louis fold the new strip of paper into fourths, fifths, or sixths? Explain your thinking.

Did you explain your thinking?



Name: _____

Date: _____



Using Equivalent Fractions to Solve Problems

- ① A list of numbers is shown.

100,000,000 1,000,000,000 1,000,000

Which comparison lists these numbers from least to greatest?

1,000,000 < 100,000,000 < 1,000,000,000

1,000,000,000 < 100,000,000 < 1,000,000

- ② Circle the 2 fractions that are equivalent.

$\frac{5}{6}$

$\frac{2}{3}$

$\frac{8}{12}$

- ③ Fill in the missing numbers.

$$\frac{2}{5} = \frac{\boxed{}}{\boxed{10}} = \frac{\boxed{8}}{\boxed{}} = \frac{\boxed{40}}{\boxed{}}$$

- ④ Mateo needs an equivalent amount of purple paint and green paint to finish his mural. He has $\frac{2}{5}$ cup of purple paint. He sees 3 bottles of green paint. One bottle has $\frac{3}{8}$ cup of green paint. Another bottle has $\frac{4}{9}$ cup of green paint. A third bottle has $\frac{6}{15}$ cup of green paint. Which bottle of green paint should Mateo use? Explain your thinking.

Did you explain your thinking?



Name: _____

Date: _____



Anjali

Relating Fractions to Decimals

① Use the model. What is the missing addend?

$$\frac{2}{3} + \frac{1}{3} + \boxed{} = 3$$

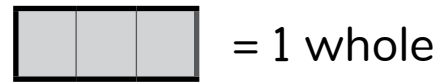

② What would Step 6 look like in this pattern?

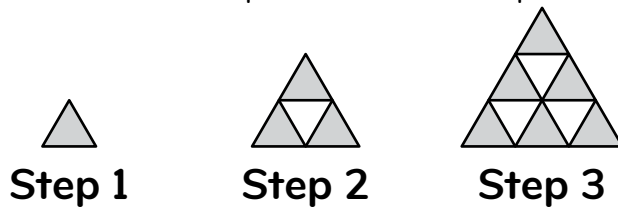

③ Write each model in words, as a fraction, and as a decimal.

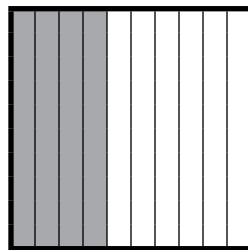
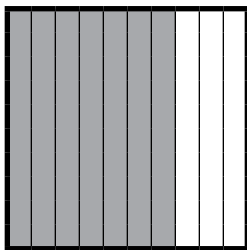

④ Write each fraction as a decimal.

$$2\frac{3}{10}$$

$$6\frac{5}{10}$$

Ones	•	Tenths
	•	

Ones	•	Tenths
	•	

⑤ On Monday, Anjali read $4\frac{3}{10}$ chapters of a mystery book. She recorded this amount as a decimal in her reading log. What decimal did Anjali write for Monday? Explain your thinking.

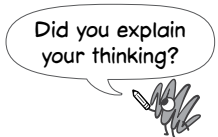

Name: _____

Date: _____

Extending Place Value to Hundredths

- ① Find an equivalent fraction.

$$\frac{(4 \times \boxed{})}{(3 \times \boxed{})} = \frac{\boxed{}}{\boxed{15}}$$

- ② Find an equivalent measurement.

1 pound (lb) = 16 ounces (oz)

$$4 \text{ lb } 18 \text{ oz} = \boxed{} \text{ lb } \boxed{} \text{ oz}$$

- ③ Write these numbers in expanded notation.

a) $17.24 = (1 \times \boxed{}) + (7 \times \boxed{}) + (2 \times \boxed{.}) + (4 \times \boxed{.})$

b) $21.35 = \boxed{\phantom{000.}}$

- ④ Finish each statement.

a) 0.04 is **one tenth**
10 times as much as 0.4.

b) 0.4 is **one tenth**
10 times as much as 0.04.

- ⑤ There are 4 critters with birthdays this week and 30 balloons for decorating. How many balloons can Jiji tie to each critter's desk so that all 4 critters have the same number of balloons? How many balloons will Jiji have left over? Explain your thinking with an equation.

Did you show your thinking with an equation?

Name: _____

Date: _____



Logan

Relating Tenths and Hundredths

- ① Solve.

$$7,231 - 4,983 = \boxed{}$$

$$6,732 - 4,568 = \boxed{}$$

- ② What is the area of the shaded part of the figure?

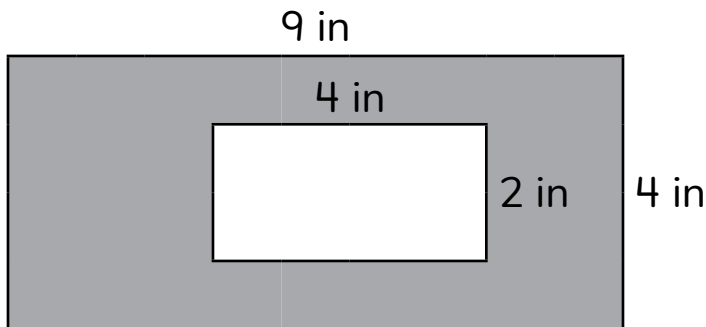

- ③ What are 2 ways to name the number represented as a point on this number line?

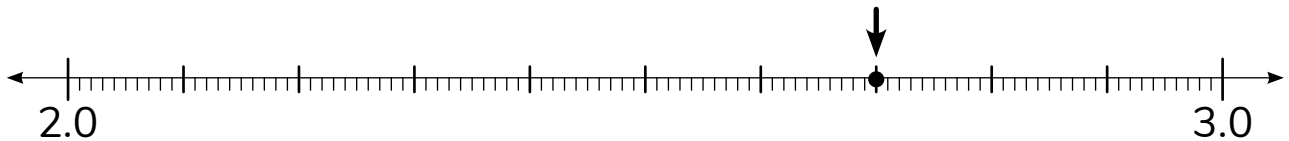

- ④ Write each fraction in decimal form.

$$\frac{7}{10} = \boxed{}$$

$$\frac{34}{100} = \boxed{}$$

$$\frac{16}{10} = \boxed{}$$

- ⑤ Logan ran 1.8 miles after school on Tuesday. Write the distance as a fraction.

Name: _____

Date: _____

Representing Distance with Fractions and Decimals

① Solve. $4\frac{1}{6} + 2\frac{5}{6} = \square$

② Round 581,938 to the following places.

nearest ten
thousand

nearest
thousand

nearest ten

③ Draw a hop on each number line to show each distance.

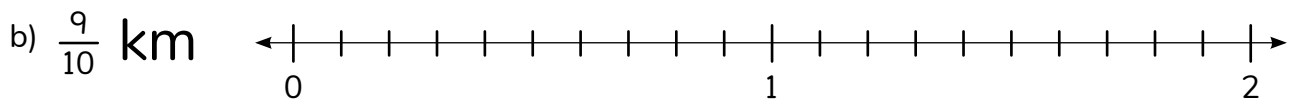
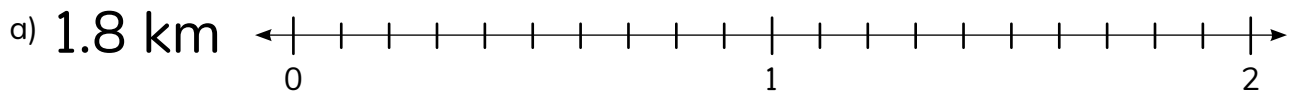

④ Over the holiday weekend, the zoo had the following visitor numbers.

The record number of visitors at the zoo in one weekend is 100,000. Did the zoo beat their record? Show how you know.

**Number of Weekend Visitors
at the Zoo**

Saturday	Sunday
50,427	48,924

Did you show
your thinking?



Name: _____

Date: _____



Mateo

Using Common Denominators and Common Numerators to Compare and Order Fractions

- ① Complete each measurement conversion.

grams = 2 kilograms

grams = 5 kilograms

- ② Solve.

$10 \times 12 =$ $11 \times 12 =$ $12 \times 12 =$

- ③ Use $<$, $>$, or $=$ to compare.

$\frac{2}{3}$ ○ $\frac{2}{5}$

$\frac{5}{8}$ ○ $\frac{3}{8}$

- ④ Fill in the numerators to make each comparison true.

$\frac{4}{6} <$ $\frac{\text{□}}{6}$

$\frac{\text{□}}{4} <$ $\frac{\text{□}}{4}$

- ⑤ Mateo painted a picture for his classroom. He covered $\frac{3}{5}$ of the painting in purple paint and covered 0.2 of the painting in gray paint. Which color covers more of the painting? Explain your thinking.

Did you explain your thinking?



Name: _____

Date: _____

Using Benchmarks to Compare and Order Fractions

1 a) Round each addend in $33,876 + 96,231$ to the nearest thousand and estimate the sum.

b) Find the precise sum.

c) How did the precise sum relate to your estimate?

2 Circle the fractions that are less than $\frac{1}{2}$. $\frac{8}{20}$ $\frac{3}{5}$ $\frac{5}{12}$ $\frac{2}{5}$

3 Order the fractions from least to greatest. $\frac{1}{2}$ $\frac{5}{6}$ $\frac{3}{4}$ $\frac{1}{3}$

4 A critter knocked the following fraction cards off the class number line: $\frac{2}{3}$, $\frac{3}{6}$, $\frac{1}{12}$, and $\frac{9}{12}$. The critter wants to put the cards on the number line from least to greatest. In what order should the cards be placed on the number line? Explain your thinking.

Did you explain your thinking?



Name: _____

Date: _____



Making Common Denominators to Compare and Order Fractions

① Solve. $5\frac{3}{6} + 7\frac{2}{6} = \square$

- ② A reading teacher has \$890 to buy new books. If each book costs \$8, how many books can the teacher buy?

Show your thinking.



③ Use $<$, $>$, or $=$ to compare. $\frac{7}{12} \bigcirc \frac{5}{8}$

- ④ Fill in the blanks to create fractions that are ordered from least to greatest.

$$\begin{array}{|c|} \hline \square \\ \hline 5 \\ \hline \end{array} < \begin{array}{|c|} \hline \square \\ \hline 2 \\ \hline \end{array} < \begin{array}{|c|} \hline \square \\ \hline \square \\ \hline \end{array}$$

- ⑤ Sarah is serving 2 casseroles that are the same size at the spring cleanup event. One casserole has already been cut into twelfths, and the other has been cut into eighths. She wants to cut both casseroles into smaller pieces that are all the same size. What fraction-sized pieces should Sarah use? Explain your thinking.

Did you explain your thinking?



Name: _____

Date: _____



Candace

Comparing and Ordering Fractions to Solve Problems

1 Complete each statement.

a) 500 is 10 times as much as .

b) 500 is 100 times as much as .

2 The gym teacher bought a new football for \$6. She bought a new badminton set for \$42. How many times as much did the badminton set cost than the football?

Show your thinking.



3 Here is the data from the soccer team's most recent game. Who was the best goal scorer in the game?

Player	Goals Made	Total Shots Taken	Fraction of Shots That Were Goals
Player A	5	8	
Player B	3	4	
Player C	5	6	

4 Write 2 fractions that are between $\frac{1}{3}$ and $\frac{2}{2}$.

5 Candace rode her bike $\frac{4}{8}$ mile on Monday. She rode $\frac{2}{6}$ mile on Tuesday. She rode $\frac{11}{12}$ mile on Wednesday.

a) On which day did Candace ride the farthest distance? Explain your thinking.

b) On which day did she ride the shortest distance? Explain your thinking.

Did you explain your thinking?



Name: _____

Date: _____

Comparing and Ordering Decimals

① Circle the numbers that are factors of 24. 2 6 7 8 12

② Write 3,982 in word form.

③ Write a decimal that makes the comparison true.

$$1.3 < \boxed{} < 1.4$$

④ What number might be represented by the point on the number line?

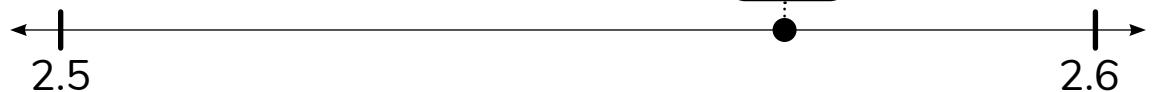

⑤ A critter is thinking of a mystery number. The number is a decimal greater than 1.7 but less than 1.8. What could the critter's mystery number be? Explain your thinking.

Did you explain your thinking?



Name: _____

Date: _____

Comparing and Ordering Fractions and Decimals

1 A rectangle has an area of 27 square inches. Its width is 3 inches.

a) What is the length of the rectangle?  Show your thinking.

b) What is the perimeter of the rectangle?

2 Would you rather play your favorite game for $8\frac{3}{5}$ minutes or 8.75 minutes?

 Explain your thinking.

3 Order the numbers from least to greatest. $1\frac{1}{10}$ $1\frac{2}{5}$ 1.01 1.25

4 Would you rather have 0.80 of your homework left to do or $\frac{3}{4}$ of your homework? Explain your thinking.

 Did you explain your thinking?

Topic 9

Extending Financial Literacy

Recommended ST Math Objectives:

Decimal Addition and Subtraction

Comparing Decimals

Fraction and Decimal Equivalence

Name: _____

Date: _____



Mateo

Adding Tenths and Hundredths

- 1 Use the model to show $\frac{4}{6} + \frac{4}{6}$.

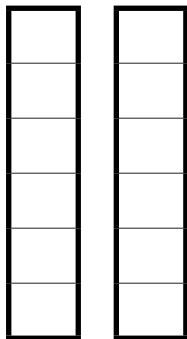

- 2 A water pitcher has a volume of 8 cups. Is the volume of 4 pitchers greater than 4 quarts?

1 pint = 2 cups
2 pints = 1 quart

- 3 Color in the model to solve.

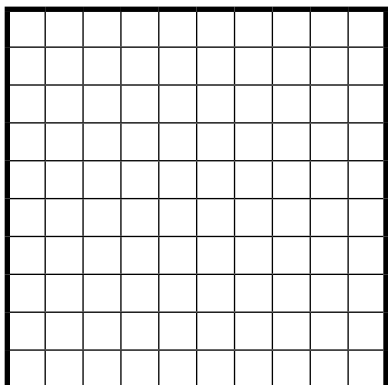

- 4 Mateo and Arturito walked from Pawty City to the dog park before walking to Pet Paradise. Find the distance they walked as a decimal.

$$\frac{6}{10} \text{ km} + \frac{24}{100} \text{ km} = \left. \begin{array}{c} \square \\ \square \end{array} \right\} \text{ km} = \square \text{ km}$$

$$0.6 + \frac{8}{100} = \square$$

- 5 A critter is working on coloring in all of the squares in a 100 grid. It colored $\frac{5}{100}$ of the grid in the morning and 0.4 of the grid in the afternoon.

- a) What is the total amount of the grid the critter has colored?
- b) Is the critter more or less than halfway finished coloring the grid? Explain your thinking.



Name: _____

Date: _____



Using Models to Add and Subtract Decimals

- ① Find the area of the figure.

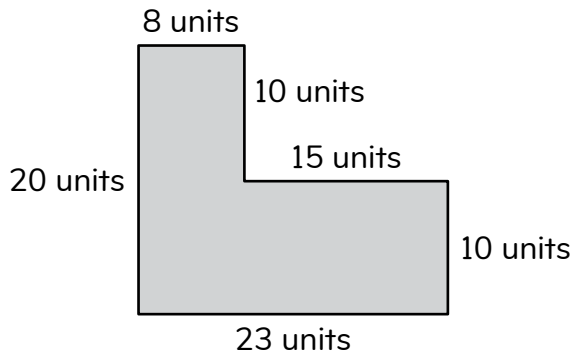

$A =$

- ② Find the product.

$$327 \times 4$$

- ③ Draw base ten blocks to solve.

$$0.73 - 0.46 = \text{$$

$$0.53 + 0.84 = \text{$$

- ④ Mateo walked his dog $\frac{5}{10}$ km in the morning and 0.8 km in the afternoon. How far did Mateo walk his dog in all? Show your thinking.

Name: _____

Date: _____



Hannah

Using Place Value Strategies to Add and Subtract Decimals

- ① Find the perimeter of the rectangle.

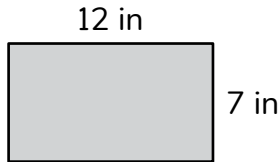

$$P = \boxed{} \text{ in}$$

- ② Use $<$, $>$, or $=$ to compare.

$$\frac{6}{10} \bigcirc \frac{7}{8}$$

- ③ Find the sum of 252.4 and 33.61.

	Hundreds	Tenths	Ones	.	Tenths	Hundredths
				.		
+				.		
<hr/>						
				.		

- ④ Find the difference between 136.18 and 115.09.

	Hundreds	Tenths	Ones	.	Tenths	Hundredths
				.		
-				.		
<hr/>						
				.		

- ⑤ Hannah bought 8 ounces of apple juice and 48 ounces of fruit punch at the grocery store. How many times as many ounces of fruit punch did she buy compared to apple juice? Show how you know.

Name: _____

Date: _____



Hannah

Creating and Interpreting Stem-and-Leaf Plots with Decimals and Mixed Numbers

- 1 a) Write each fraction as a decimal.

$$\frac{148}{100}$$

$$\frac{15}{10}$$

$$\frac{14}{10}$$

- b) Circle the greatest fraction.
Put a square around the decimal with the smallest value.

- 2 This list shows the heights in inches of Humboldt penguins in the zoo exhibit.

- a) Represent this data in a stem-and-leaf plot and in a frequency table.

25.9, 27.1, 26.4, 26.3, 25.9, 26.5, 26.8, 27.4, 27.1, 26.4, 27.3, 27.6, 26.6, 27.0, 26.2

Height of Humboldt Penguins in the Zoo Exhibit (inches)

Stem	Leaf

25|9 means 25.9 inches.

Height of Humboldt Penguins in the Zoo Exhibit

Height (inches)	Number of Penguins
less than 26	
26 to less than 27	
27 and greater	

- b) What is the difference in height between the shortest penguin and the tallest penguin?

- 3 Hannah's family sold 15 dozen eggs at the farmers market each month last year. Many eggs did they sell in all?

1 dozen = 12
1 year = 12 months

Name: _____

Date: _____



Solving Problems with Money Using Decimal Addition and Subtraction

Hannah

- 1 Write an expression to match the model.



- 2 Find the product. $73 \times 32 =$

- 3 I just bought a new game for \$21.96. I have this much money left.

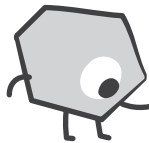

How much money did I start with?



- 4 Last week, Hannah collected 252 eggs from the chickens on her family's farm. She packed the eggs into cartons, with 6 eggs in each carton. If she sells 7 cartons of eggs each day, how many days will it take to sell all of the cartons?

Name: _____

Date: _____



Introducing Fixed and Variable Expenses

- 1 Draw a number line to model and solve the problem.

$$\frac{3}{8} + \boxed{} = \frac{15}{8}$$

- 2 Complete the table.

Yards (yd)	Feet (ft)
1	3
4	
7	
12	

- 3

Which expenses are variable expenses and which expenses are fixed expenses?

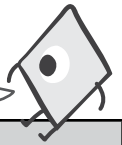

Monthly Expenses			
Expenses	Month 1	Month 2	Month 3
Electricity	\$96.58	\$83.19	\$110.75
Rent	\$1,350.00	\$1,350.00	\$1,350.00
Streaming Services	\$70.00	\$70.00	\$70.00
Groceries	\$435.46	\$281.53	\$373.50

- 4 Dani is building birdhouses with her older brother.

- Each birdhouse needs 12 pieces of wood.
- Dani wants to build 7 birdhouses.
- The wood comes in bundles of 6 pieces each.

How many bundles of wood does Dani need to order? Show how you know.

Name: _____

Date: _____

Using an Allowance to Plan Spending, Saving, and Sharing

① Create a true comparison.

\circ $\frac{1}{2}$

8

② $400 \times 100 =$

③ My weekly allowance is \$4.75. If I save my whole allowance for 7 weeks, how much money will I have?



Week	1	2	3	4	5	6	7
Allowance Saved	\$4.75						



How many weeks will it take me to save up enough money to buy the train set?

weeks

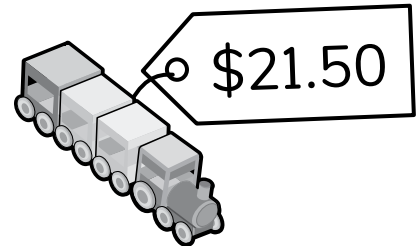

④ Third-, fourth-, and fifth-grade students across the state read a total of 66,124 pages for a statewide reading challenge.

- Third-grade students read 19,832 pages.
- Fourth-grade students read 20,389 pages.
- Fifth-grade students read the rest.

How many pages did fifth-grade students read? Show how you know.

Name: _____

Date: _____



Solving Problems Involving Business Expenses and Profit

- ① What is the value of the digit 6 in the number 764,829?

- ② This model is shaded to represent a fraction. Write a fraction that is less than the value represented by the model.

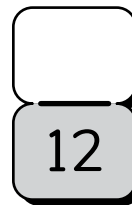
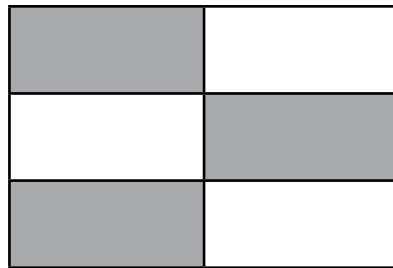

- ③  I purchased string for \$8 and beads for \$6 to make necklaces. I sold all the necklaces for \$25. What is my profit?

- ④ Mateo and his *abuela* painted a mural for a neighborhood art festival. Mateo painted $\frac{3}{4}$ of the mural and his *abuela* painted the rest. How much of the mural did Mateo's *abuela* paint?

Name: _____

Date: _____



Comparing Savings Options: Home, Checking, and Savings Accounts

Mateo

Logan

- ① Use $<$, $>$, or $=$ to compare.

$$1.2 \bigcirc \frac{1}{2}$$

- ② Fill in the missing numbers to complete the equation.

$$\frac{4}{10} + \frac{38}{100} = \frac{\boxed{}}{\boxed{100}} + \frac{38}{100} = \frac{\boxed{}}{\boxed{}}$$

- ③ Mateo started the month with \$100 in his checking account.

At the end of the month, he had \$ in his checking account.

Checking Account Monthly Bank Statement

Date	Transaction Description	Withdrawal	Deposit
3/4	electronic payment	\$24.59	
3/15	cash		\$50.00
3/31	check deposit		\$115.25

- ④ Logan biked $\frac{3}{10}$ mile in the morning and 0.5 mile in the afternoon.

Did Logan bike farther in the morning or in the afternoon? Show how you know.

Did you show your thinking?



Name: _____

Date: _____



Solving Problems and Making Financial Decisions

- 1 Complete the statements.

18 is a multiple of .

is divisible by 4.

- 2 Find the difference.

$$238.05 - 95.37$$

- 3 Using the information from the table, decide what to do with the income from this month.

Income This Month

	Allowance	Yard Cleanup
Week 1	\$7.00	\$9.50
Week 2	\$7.00	\$12.75
Week 3	\$7.00	\$15.00
Week 4	\$7.00	\$10.25
Total		

Save \$ in
a savings account.

Donate \$ to

Spend \$ on

- 4 Logan spent \$4.25 on a snack and \$1.75 on a drink from the vending machine. If she still has \$3.25, how much money did Logan have to start with? Show your thinking.

Did you show
your thinking?



Topic 10

Exploring Shapes, Lines, and Angles

Recommended ST Math Objectives:

Lines and Angles

Classifying Shapes

Lines of Symmetry

Name: _____

Date: _____

Exploring Points, Lines, Rays, and Line Segments

- ① Fill in the numerator to make each equation true.

$$\frac{7}{10} = \frac{\boxed{}}{\boxed{100}}$$

$$\frac{\boxed{}}{\boxed{10}} = \frac{60}{100}$$

- ② Use $<$, $>$, or $=$ to compare.

$$1.2 \bigcirc 1.25$$

- ③ Draw a shape that matches these clues:

- It is a closed shape.
- It has 6 sides.
- It has a pointed top.
- It is made up of line segments.

- ④ Draw a ray.

- ⑤ A critter drew a closed shape with 4 line segments. Then, the critter added a ray to the drawing. Draw the critter's shape. Explain how your shape matches the critter's shape.

Did you explain your thinking?



Name: _____

Date: _____

Relating Lines, Rays, and Line Segments

- ① Write each fraction as a decimal number.

$$\frac{7}{10} = \boxed{}$$

$$\frac{686}{100} = \boxed{}$$

- ② a) Complete the pattern. 1, 1, 2, 3, 5, 8, 13, $\boxed{}$, 34
b) What is the rule for this pattern?

- ③ Circle the pair of lines that appear parallel. Explain your thinking. 

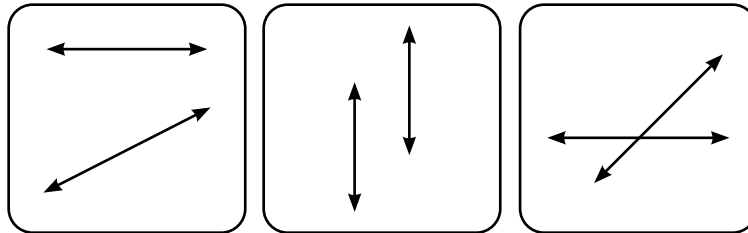

- ④ Circle the pair of lines that appear perpendicular. Explain your thinking. 

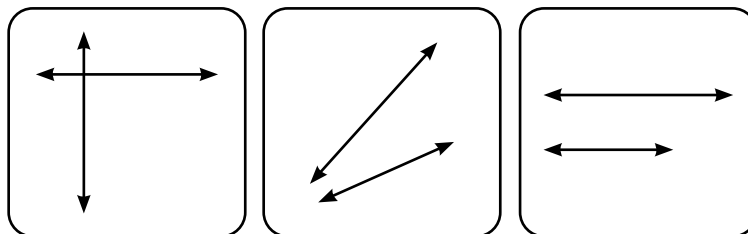

- ⑤ A critter wrote 3 uppercase letters. Each letter has at least 1 set of parallel lines. Which uppercase letters could the critter have written? Explain your thinking.

Did you explain your thinking?



Name: _____

Date: _____



Introducing Angles

- ① Hannah sold pies made with blueberries from her family's farm. The cost of preparing the pies was \$13.45. The money she received from the sale of the pies was \$34.22. What was Hannah's profit?

② Solve. $37 \times 86 = \boxed{}$

- ③ Circle the acute angle.

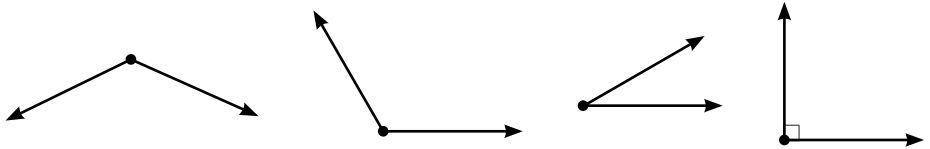

- ④ Draw an obtuse angle.

- ⑤ Logan looked at the clock to see if it was time for track practice to start. The hands of the clock formed a right angle. What time could the clock have shown? Explain your thinking.

Did you explain your thinking?



Name: _____

Date: _____



Candace

Introducing Degrees

1 Complete each statement.

a) 56 is times as much as 7.

b) 24 is times as much as 6.

2 Solve.

$$834 \div 6 = \boxed{}$$

$$1,192 \div 8 = \boxed{}$$

3 How many degrees are in $\frac{1}{10}$ of a turn around a circle?

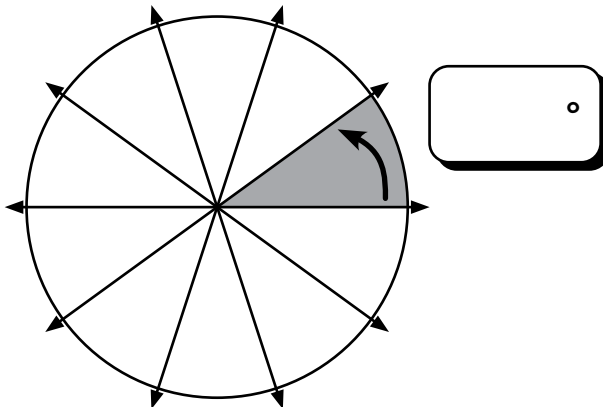

4 How many 90° angle turns make up a circle?

5 Candace looked up the population of each town her team visited last weekend for soccer games. Town A's population is 42,788 people and Town B's population is 39,794 people. What is the total population of both towns? Show your thinking.

Did you show your thinking?



Name: _____

Date: _____



Sarah

Measuring Angles

- 1 Use $<$, $>$, or $=$ to compare.

0.6 ○ 0.60

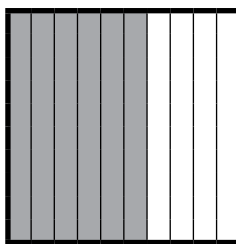

0.6

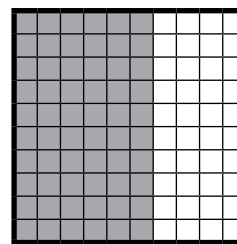

0.60

- 2 Complete the statement.

0.5 is **one tenth ten times** as great as 0.05.

- 3 What is the measure of each angle?

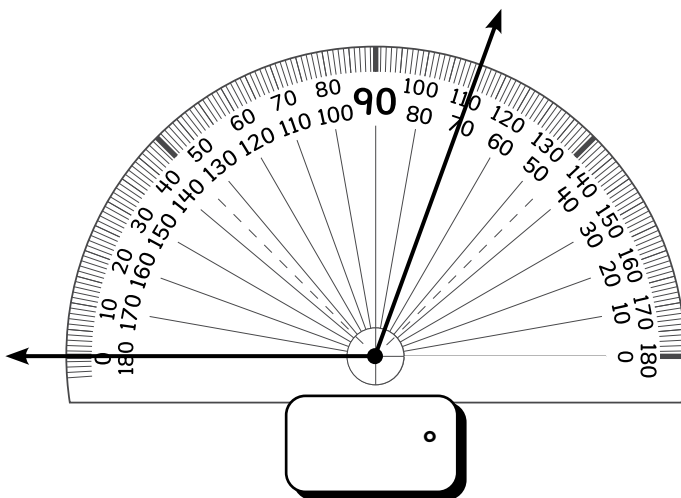
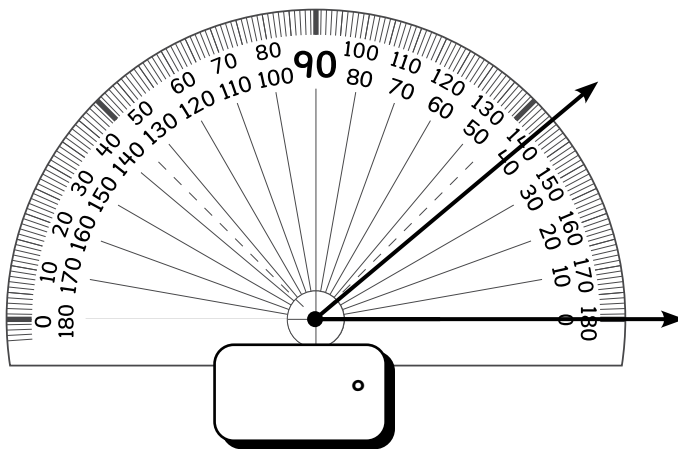

- 4 Sarah explored the soil in a raised flower bed and counted the creatures she came across. She counted 38 ants, 24 earthworms, 6 snails, and 15 centipedes. Using estimation, do you think Sarah found at least 100 creatures? Explain your thinking.

Did you explain your thinking?



Name: _____

Date: _____

Relating Angles and Estimating Angle Measurements

- ① Complete the inequality to make it true.

$$\frac{1}{4} < \begin{array}{|c|} \hline \\ \hline \hline \hline 6 \\ \hline \end{array}$$

- ② A number is shown in expanded notation.

$$(8 \times 1,000) + (4 \times 100) + (2 \times 1) + (3 \times 0.1) + (9 \times 0.01)$$

What is the number in standard form?

- ③ a) Estimate the measure of $\angle DEF$.

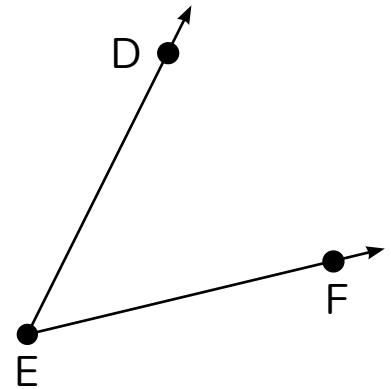

- b) Use a protractor to find the actual size of $\angle DEF$.

- ④ Critter A ate $\frac{5}{12}$ of its bag of peanuts. Critter B ate $\frac{8}{9}$ of its bag of peanuts. Critter C ate $\frac{5}{10}$ of its bag of peanuts. Each bag of peanuts is the same size. Put the amount each critter ate in order from least to greatest. Explain your thinking.

Did you explain your thinking?



Name: _____

Date: _____



Miles

Solving Problems Involving Angles

1 Complete each statement.

a) 12,758 rounded to the nearest 100 is

b) 12,758 rounded to the nearest 1,000 is

c) 12,758 rounded to the nearest 10,000 is

2 Solve. $43,873 - 27,984 =$

3 Find the measure of $\angle PQS$ without using a protractor.

$$\angle PQR = 142^\circ$$

$$\angle PQS =$$

$\angle PQS$ is acute right obtuse.

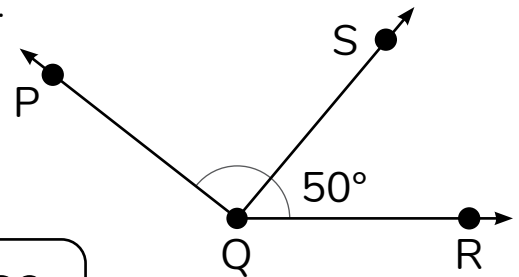

4 Without using a protractor, find the measure of $\angle TJO$.

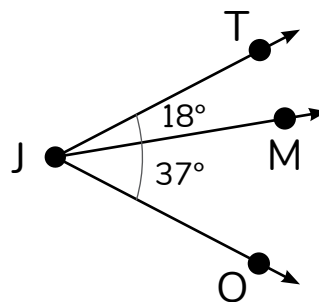

5 Miles has 12 full storage cases for his toy car collection. If each case holds 25 cars, how many total toy cars are in Miles's collection? Show your thinking.

Did you show your thinking?



Name: _____

Date: _____



Sorting, Classifying, and Naming Triangles

- 1 Use the number lines to find a fraction equivalent to $\frac{6}{4}$.

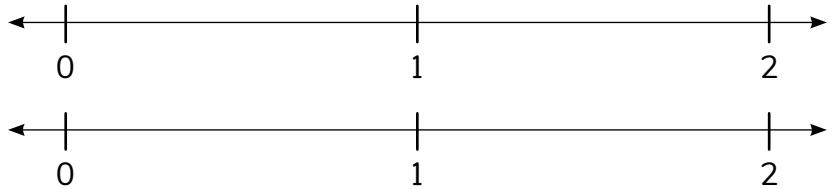

2 Solve. $\frac{2}{10} + \frac{34}{100} =$

- 3 Circle the words that describe this triangle.

obtuse **isosceles**
equilateral **acute**
right **scalene**

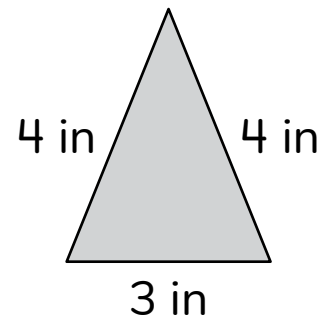

- 4 A triangle can have 2 right angles. **sometimes** **always** **never**



Explain your thinking.

- 5 Louis needs 8 cans of beans for each large batch of chili he makes. If Louis has 94 cans of beans, how many batches of chili can he make? Explain your thinking.

Did you explain your thinking?



Name: _____

Date: _____

Sorting, Classifying, and Naming Quadrilaterals

- 1 The width of the rectangle is 3 cm. The area is 21 square cm.

Show your thinking.



- a) What is the length of the rectangle?
- b) What is the perimeter of the rectangle?

- 2 Use $<$, $>$, or $=$ to compare.

294,427 ○ 249,427

- 3 What is the same about a parallelogram and a rectangle? What is different?

parallelogram

rectangle

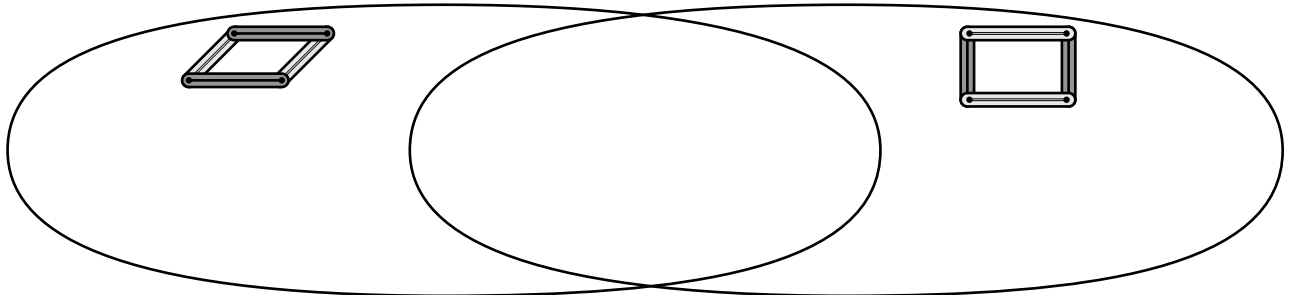

- 4 A quadrilateral has parallel sides and 2 acute angles.
What shape could it be? Draw a picture and name the shape.

- 5 3 critters each made a triangle using AngLegs. Critter A used only 1 color of AngLegs. Critter B used 2 different colors of AngLegs. Critter C used 3 different colors of AngLegs. What type of triangle did each critter make? Explain your thinking.

Did you explain your thinking?



Name: _____

Date: _____



Using Attributes to Compare Quadrilaterals

- 1 This table shows Mateo's expenses for the bus fees and art supplies.

Which of Mateo's expenses are fixed expenses?

Mateo's Expenses

Month	Bus Fees	Art Supplies
January	\$10.00	\$8.50
February	\$10.00	\$5.25
March	\$10.00	\$12.00
April	\$10.00	\$7.75

- 2 A quadrilateral has opposite sides that are parallel, and all of its sides are congruent. All of the angles are congruent and measure 90° . What is the quadrilateral?

- 3 How would you describe this shape? Use the words *parallel*, *congruent*, and *opposite* in your description.

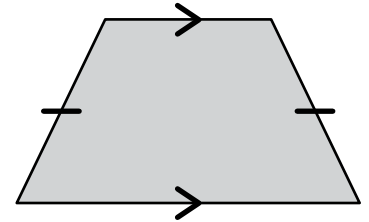

- 4 Dani made a wooden shelf as a birthday present for her brother. She placed 4 kg of books on the shelf for him. What is the mass of the books on the shelf, in grams? Explain your thinking.

Did you explain your thinking?



Name: _____

Date: _____



Introducing Lines of Symmetry

① Write $55\frac{61}{100}$ as a decimal.

② Solve.

$$327 \times 5 = \boxed{}$$

③ How many lines of symmetry can you find for this trapezoid? Draw each line of symmetry.

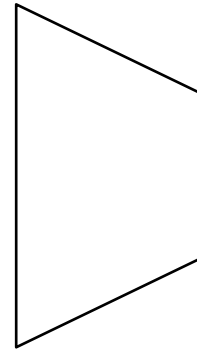

④ Does a triangle always have more lines of symmetry than a rectangle?  Explain your thinking.

⑤ Sarah drew 4 different quadrilaterals. 2 of the quadrilaterals have a line of symmetry. 2 of the quadrilaterals do not have a line of symmetry.

a) Which quadrilaterals could Sarah have drawn? Explain your thinking.

b) Which of Sarah's shapes have symmetry and which do not? Explain your thinking.

Did you explain your thinking?



Name: _____

Date: _____



Exploring Lines of Symmetry

- ① Create a mixed number that represents 25.7.

$$25.7 = \frac{\boxed{}}{10}$$

- ② Complete each measurement conversion.

$$1 \text{ km} = \boxed{} \text{ m}$$

$$1 \text{ m} = \boxed{} \text{ cm}$$

- ③ Circle the regular polygons.

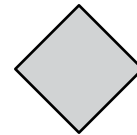
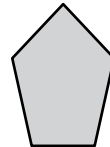
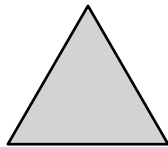

- ④ What is the same about a square and a rhombus? What is different?

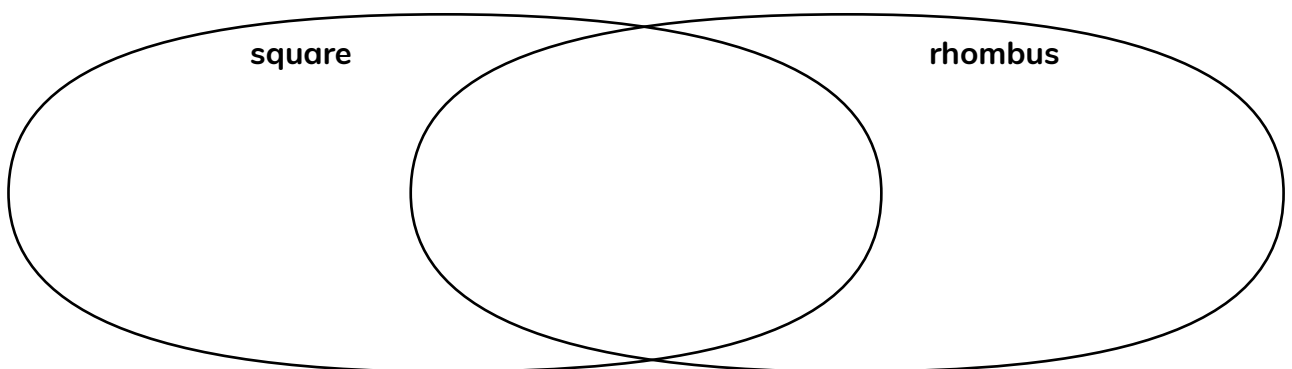

- ⑤ Mateo drew a regular polygon with exactly 3 lines of symmetry. What shape did Mateo draw? Explain your thinking.

Did you show your thinking?



Topic 11

Making Connections with Time and Data

Recommended ST Math Objectives:

Measurement and Conversions

Dot Plots

Multi-Step Addition and Subtraction Problems

Name: _____

Date: _____



Sarah

Representing Elapsed Time on a Number Line

1 a) What is the measure of this angle?

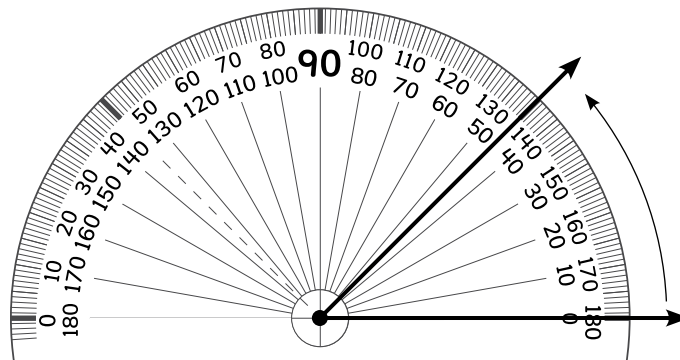

b) Is it acute, obtuse, or right?

2 Use $<$, $>$, or $=$ to compare.

0.82 ○ 0.8

3 What time is shown on the clock?

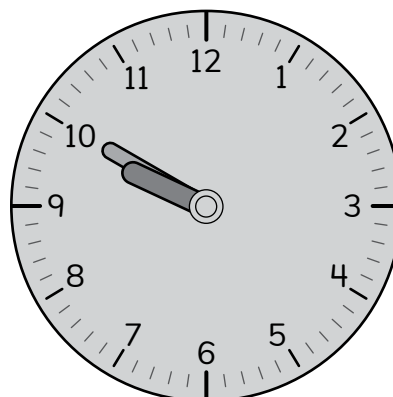

4 If a soccer game begins at 12:15 p.m. and lasts for 1 hour and 20 minutes, what time will the soccer game end? Use the timeline to show your thinking.

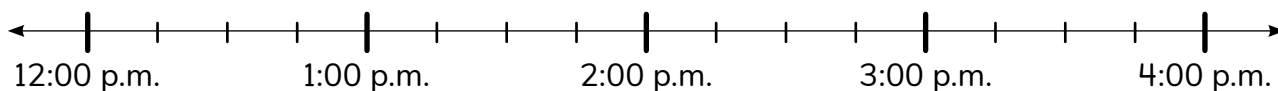

5 Sarah and her dad started working in the community garden at 3:50 p.m. They finished working at 5:05 p.m. How long did Sarah and her dad work in the garden? Explain your thinking.

Did you explain your thinking?



Name: _____

Date: _____



Naomi

Solving Elapsed Time Word Problems

- 1 Is this triangle acute, obtuse, or right?



Explain your thinking.

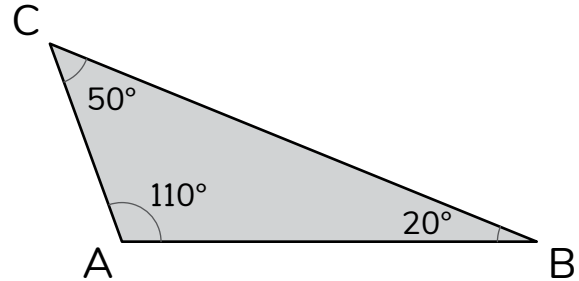

- 2 Draw all the lines of symmetry for this shape.

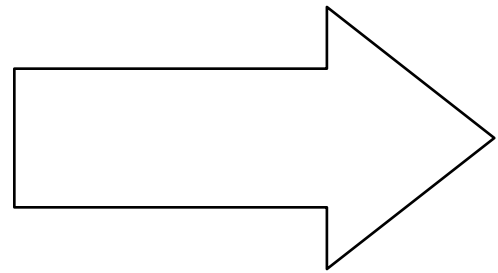

- 3 Naomi's family walked on the beach for 75 minutes. They started their walk at 8:30 a.m. At what time did they finish their walk? Use the timeline to show your thinking.

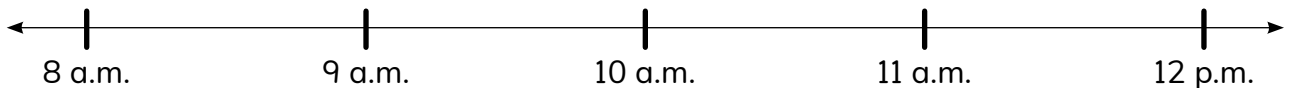

- 4 Naomi's family left the beach at 3:15 p.m. They stopped for dinner and got home at 7:00 p.m. How much time passed between leaving the beach and arriving home? Use the timeline to show your thinking.



- 5 What time is shown on the clock? What time will it be in 0.25 hours? Explain your thinking.

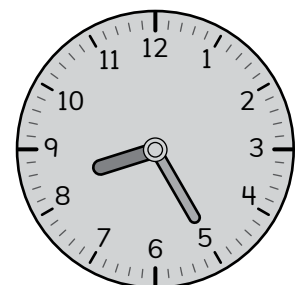

Did you explain your thinking?



Name: _____

Date: _____



Using Open Timelines to Solve Problems

① Solve. $\frac{3}{10} + \frac{28}{100} =$

$\frac{5}{10} + \frac{49}{100} =$

② Write 0.83 as a fraction.

- ③ Aleki and his uncle spent 53 minutes driving to a carnival. They spent 15 minutes standing in line to enter the carnival. If they left home at 9:00 a.m., what time did they enter the carnival?

Show your thinking with a number line.

- ④ Aleki and his uncle got in line for a ride at 10:45 a.m. They got off the ride at 11:17 a.m. Which ride did they go on?

Show your thinking with a number line.

Wait and Ride Times	
Roller Coaster: 48 minutes	Carousel: 25 minutes
Alien Swings: 30 minutes	Ferris Wheel: 50 minutes
Pirate Ship: 32 minutes	

- ⑤ What time is shown on the first clock? Draw the hands on the second clock to represent a time $2\frac{3}{4}$ hours later.

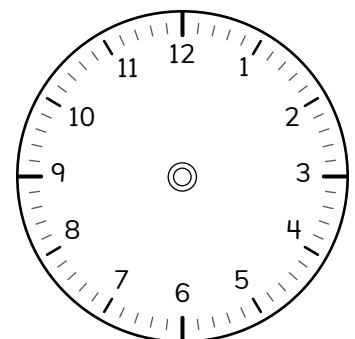
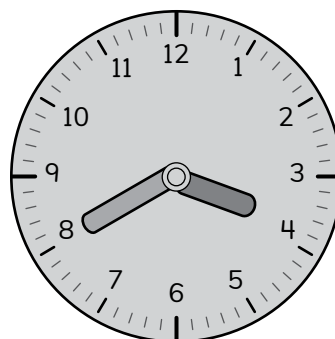

Name: _____

Date: _____



Exploring Angles and Fractions on Clocks

- ① Solve.

$$\frac{8}{8} + \frac{7}{8} = \boxed{}$$

$$6\frac{1}{3} - 1\frac{2}{3} = \boxed{}$$

- ② How many degrees are $\frac{1}{8}$ of a circle?

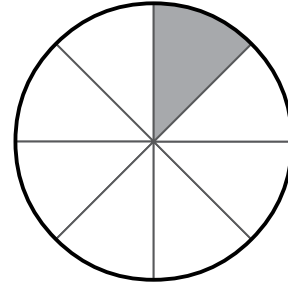

- ③ a) What time is it when the hour hand has rotated $\frac{1}{3}$ around the clock from 12:00?

- b) What time is it when the minute hand is 180 degrees past 12:00?

- c) What time is it when the minute hand is 90 degrees past 12:00?

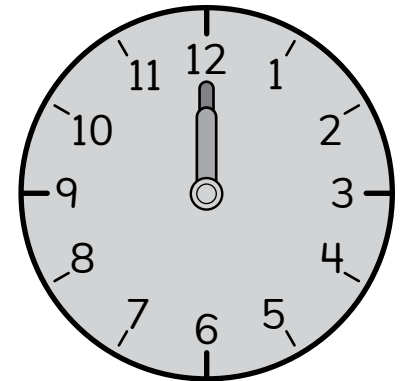

- ④ Logan started a run at 4:52 p.m. She finished at 5:43 p.m. How many minutes did Logan run? Explain your thinking.

Did you explain your thinking?



Name: _____

Date: _____



Louis

Telling Time Using Angles and Fractions

- ① $\angle RQT$ has a measure of 70° .
 $\angle RQS$ has a measure of 30° .
What is the measure of $\angle SQT$?

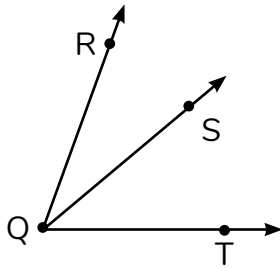

- ② Are these lines parallel?



Explain your thinking.

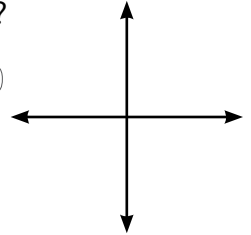

- ③ Complete each measurement conversion.

$$\frac{1}{4} \text{ hour} = \boxed{} \text{ minutes}$$

$$\frac{2}{3} \text{ hour} = \boxed{} \text{ minutes}$$

$$\frac{3}{4} \text{ hour} = \boxed{} \text{ minutes}$$

- ④ What time is shown on the clock?

Explain your thinking.

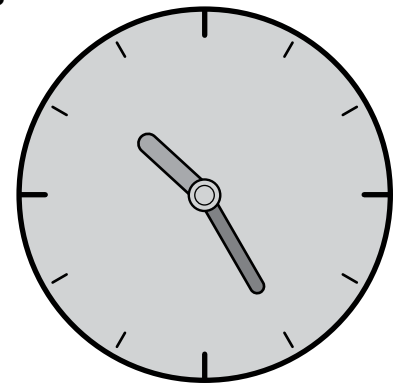

- ⑤ Louis went to the basketball court to practice 3 days this week. He went for $\frac{2}{3}$ of an hour the first day, $\frac{3}{4}$ of an hour the second day, and $\frac{2}{3}$ of an hour the third day.
How many total minutes did Louis practice this week? Explain your thinking.

Did you explain your thinking?



Name: _____

Date: _____



Converting Between Units of Time

- 1 a) What is the area of the rectangle?

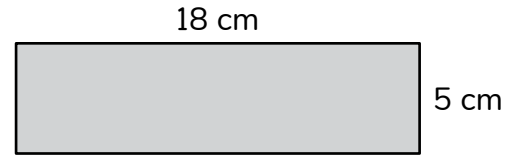

- b) What is the perimeter of the rectangle?

- 2 What is 3 times as much as 32×4 ?

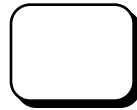

- 3 Dani spent 3 times as long as her brother creating a blueprint for a new bookshelf. If Dani spent 45 minutes on the blueprint, how long did her brother spend on the blueprint?

- 4 Dani spent 75 minutes painting the bookshelf. Her brother spent 3 times as long as Dani to finish painting the bookshelf. How long did it take Dani's brother to finish painting the bookshelf?

Name: _____

Date: _____

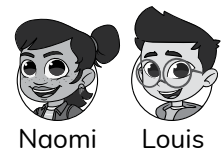

Exploring Patterns with Multiples Involving Time

1 Solve. $4,872 + 6,150 =$

- 2 Naomi is decorating notebooks for a party. She has 3 blue notebooks, 2 purple notebooks, and 3 green notebooks. She has 126 stickers. Naomi puts the same number of stickers on each notebook. If she puts as many stickers as possible on each notebook, how many stickers will she have left?  Show your thinking.

- 3 If a bell rings at 12:00 p.m. and then rings every 25 minutes, when is the next time that it will ring on the hour?



Show your thinking.

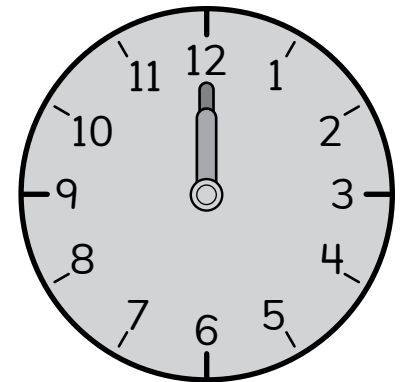

- 4 The cafeteria is open between 10:45 a.m. and 1:00 p.m. If each grade level gets 25 minutes for lunch, how many grade levels can the cafeteria serve? 

Explain your thinking.

- 5 Louis was tracking game attendance for his favorite basketball team. Attendance at Tuesday night's game was 16,302 people. Attendance at Friday night's game was 289 fewer people than at Tuesday's game. What was the attendance at Friday night's game? Show your thinking.

Did you show your thinking?



Name: _____

Date: _____



Logan

Solving Problems with Time-Based Data

1 Use $<$, $>$, or $=$ to compare.

3.40 ○ 3.4

0.8 ○ 0.08

1.2 ○ 2.1

2 What is the measurement of the angle?

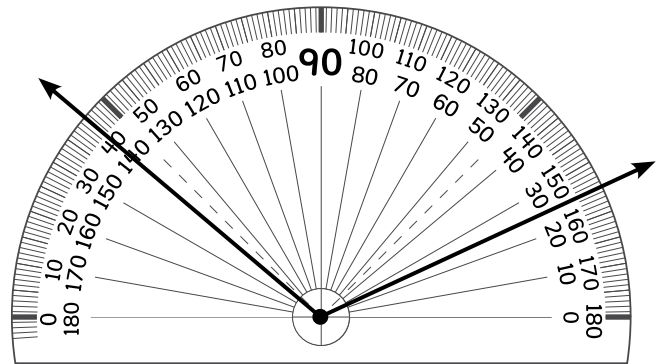

3 A cat sleeps about 16 hours a day.

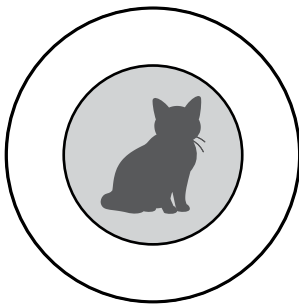

a) Shade the circle to show about how long a cat sleeps.

b) What fraction of the day do cats sleep?

4 Dogs sleep about 8 hours each day, as shown in this model. Using the data from Problem 3, how does the amount of time a dog sleeps each day compare to the amount of time a cat sleeps each day? Circle the statement you agree with.

- Dogs sleep 2 times as many hours as cats.
- Cats sleep 2 times as many hours as dogs.
- Dogs and cats sleep the same amount of time.

Explain your thinking.

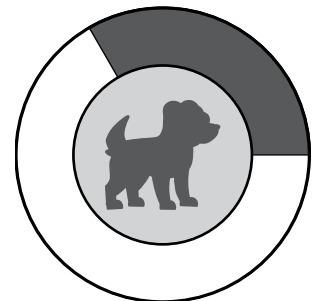

Name: _____

Date: _____



Solving Problems with Time Estimates

- 1 Circle all of the names for this quadrilateral.

square rectangle
rhombus trapezoid

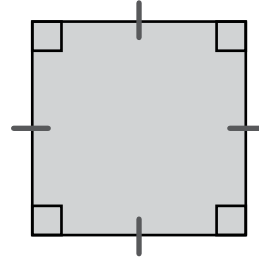

- 2 What is the value of the underlined digit in 1,000,000,000?

- 3 During a road trip, Candace's family stops for a break. They spend 2 hours and 14 minutes at a state park. How many minutes do they spend at the park? *Show your thinking.*

- 4 Candace's family was away from home for 1 week, 3 days, and 15 hours. How many hours was Candace's family away from home? *Show your thinking.*

- 5 If Louis used 2.5 kilograms of flour to make muffins, how many total grams of flour did Louis use? Show your thinking.

Did you show your thinking?



© 2026 MIND Education®. All Rights Reserved.

