



ST Math
Texas

Grade 3

ST Math Practice Book

Whose book
is this?

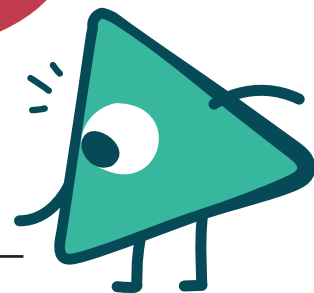

Building Mathematical Progressions Within and Across Grade Levels

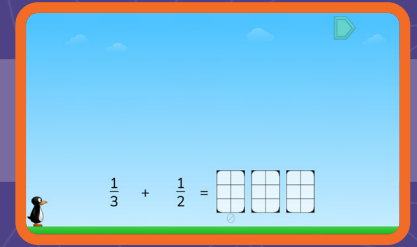
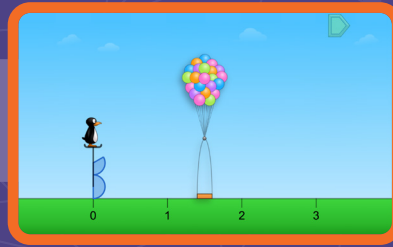
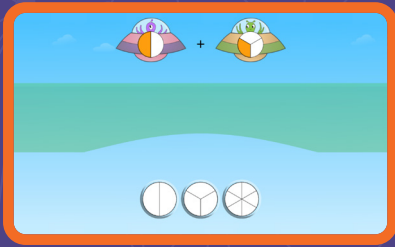

Multiple models for every concept within a grade level

Visual-First Learning That Makes Math Click

ST Math Texas is built around a patented visual-first approach that helps students see and understand math. Interactive visuals activate students' spatial-temporal reasoning, building deep understanding even before introducing formal language or procedures.

These scaffolded models support problem-solving, strategy sharing, and big-picture thinking—making math feel coherent and connected across and within grade levels.

To deepen learning, lessons use multiple representations—visuals, numbers, words, and symbols—helping students form a rich network of ideas they can apply to new problems.

With **ST Math Texas** students go beyond memorization. They develop a connected understanding of math concepts, apply their learning flexibly, and build lasting confidence.

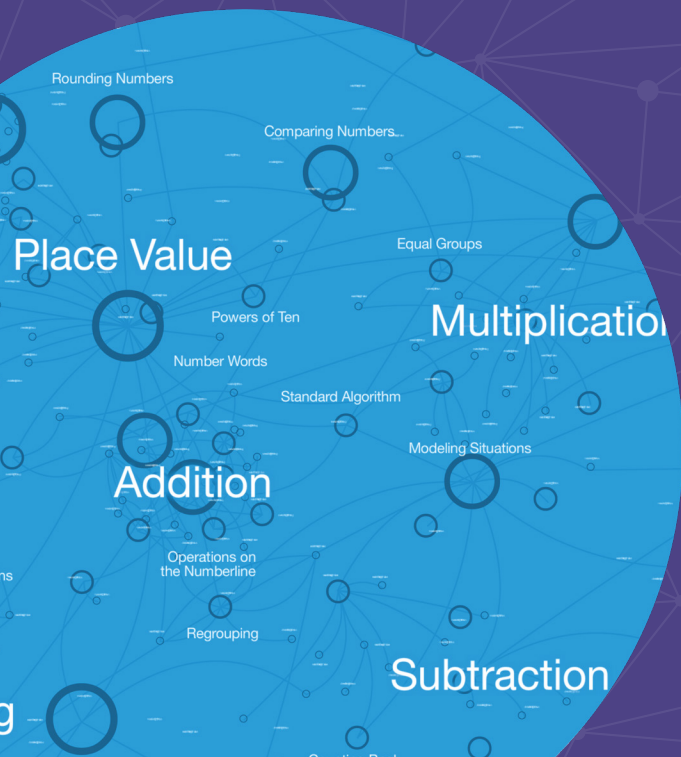

Expressions
Grade 5

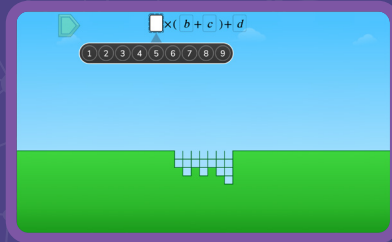

Fractions
Grade 4

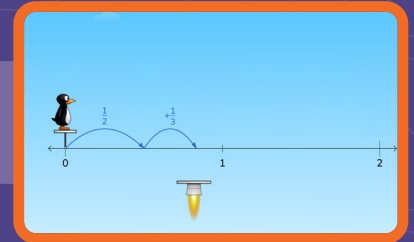
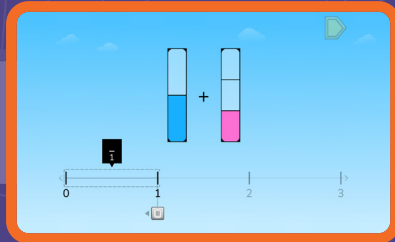

Multiplication
Grade 3

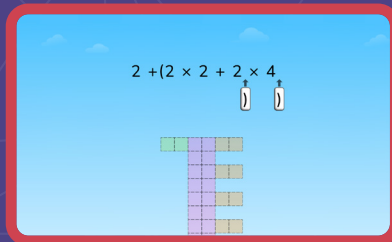

Connected visual
models build in
complexity across
grade levels

Subtraction
Grade 2

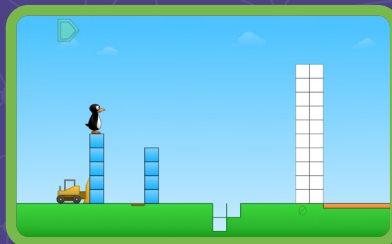

Addition
Grade 1

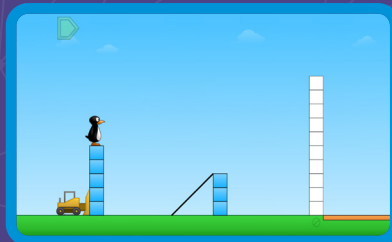

Counting
Grade K

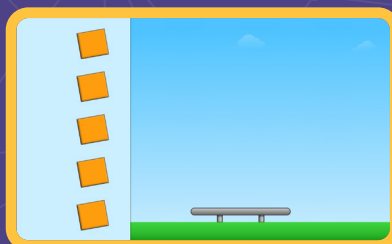

©2026 by MIND Education. All rights reserved.

No part of this work may be used or reproduced in any manner whatsoever without the written permission of MIND Education.

MIND Research Institute
5281 California Avenue, Suite 300
Irvine, CA 92617

How to Use This Document

This practice book is a standards-based, year long practice book companion to ST Math Texas.

To use this book in conjunction with ST Math Texas, find the digital games and objectives tied to each Topic. The hyperlinks will take you to the page that allows you to assign the ST Math Texas Objectives that go along with these practice pages.

These pages are designed to be printed and solved with paper and pencil. They come with spiral review, related topics and problems, and world problems that connect to the world around us.

Our help site offers further ties between ST Math, this practice book, and your school or district's curriculum.

Content Overview

Topic 1 (Discovering Multiplication and Division) introduces students to the operations of multiplication and division. This Topic focuses on building a strong conceptual foundation of the mathematics of equal groups, modeling multiplication situations, multiplication and division as inverse operations, and the efficiency of multiplication and division in place of repeated addition and subtraction.

Students explored the attribute of area informally in grade 2, and now in **Topic 2 (Discovering Area)**, they formally explore area of two-dimensional shapes. They directly measure area with Topic squares before discovering that multiplication can be used to indirectly measure the area of a rectangle. This work with area early in the course supports the use of area models of multiplication in subsequent topics.

In **Topic 3 (Exploring Multiplication and Division Strategies)**, students begin to develop more efficient multiplication strategies by using known foundational facts (such as 2s and 10s) to derive unknown facts using strategies such as grouping, partitioning, and compensation. They use their knowledge of area in order to use area as a model for multiplication and to support strategy development.

Students delve deeper into two-dimensional shapes in **Topic 4 (Discovering Perimeter and Exploring Area)**, differentiating between quantifying the size of shape as perimeter or area and investigating the relationship between the two. Students synthesize their understanding of area, multiplication, and division in **Topic 5 (Extending Multiplication and Division Strategies)** as they pair symbolic representations with area models, multiply and divide fluently, and extend their strategies to multidigit numbers.

In **Topic 6 (Using Place Value to Add and Subtract)**, the focus shifts to place value understanding and how that supports comparison, addition, and subtraction of multidigit numbers. As students begin working with greater numbers, there is an emphasis on real-world examples in order to support understanding of magnitude.

In earlier grade levels, students partitioned shapes into equal shares and described the pieces as halves, thirds, etc. **Topic 7 (Discovering Fractions)** formally introduces students to fractions and fractional notation. Students first come to understand Topic fractions as one piece of a whole, and then extend their understanding to non-Topic fractions through both iteration and partitioning. This builds on students' schema of iterating topics of length and area. In **Topic 8 (Exploring Fractional Thinking)**, students extend their understanding of fractions in order to generate simple equivalent

fractions and to make comparisons. They come to understand fractions as numbers and recognize that there are many equivalent ways to represent the same number.

In Topic 9 (Exploring Measurement), students make use of their new knowledge of fractions to understand measurement as continuous, and express length measurements as fractions. They also extend their measurement schema to the attributes of volume and weight. With a larger repertoire of ways in which to quantify size, they learn to select appropriate attributes and topics in context.

Topic 10 (Deepening Financial Literacy) provides students with an opportunity to apply their addition and subtraction skills to solve problems related to money while also considering how financial decisions impact one another. Students complete the year applying their skills to more real-world contexts in **Topic 11 (Investigating Data)**.

Topic 1: Discovering Multiplication and Division

ST Math Objectives: Multiplication Concepts, Division Concepts, Multiplication and Division Relationships

TEKS: 1.1.F 3.1.A 3.1.B 3.1.C 3.1.D 3.1.E 3.1.F 3.1.G 3.2.D 3.4.D 3.4.E 3.4.F 3.4.G 3.4.H 3.4.I 3.4.K 3.5.B 3.5.C 3.5.D 3.8.B

ELPS: 1.A 1.B 1.C 1.E 1.F 2.A 2.B 2.C 2.D 2.E 3.A 3.C 3.E 3.F 3.G 3.H 4.A 4.D 4.E 4.F

Exploring Equal Groups.....	7
Using Equal Groups to Find the Total.....	8
Writing Repeated Addition Equations to Model Equal Groups.....	9
Introducing Multiplication.....	10
Modeling and Solving Multiplication Problems with Equal Groups.....	11
Modeling and Solving Partitive Division Problems.....	12
Modeling and Solving Quotitive Division Problems.....	13
Interpreting Division Situations.....	14
Using Arrays to Organize Equal Groups.....	15
Modeling and Solving Word Problems Involving Arrays.....	16
Exploring the Commutative Property of Multiplication.....	17
Using the Commutative Property of Multiplication Strategically.....	18
Using Patterns to Multiply.....	19
Using Multiplication and Division Patterns to Solve Equal-Group Problems.....	20
Using Multiplication and Division to Unlock the Barn.....	21

Topic 2: Exploring Area

ST Math Objectives: Multiplication and Area, Area and Perimeter, Properties of Multiplication

TEKS: 3.1.A 3.1.B 3.1.C 3.1.D 3.1.E 3.1.F 3.1.G 3.4.E 3.4.K 3.5.B 3.6.C

ELPS: 1.A 1.B 1.D 1.E 2.B 2.D 2.E 2.F 3.C 3.F 3.G 4.A 4.C 4.D 4.E 4.F

Superimposing to Directly Compare Area.....	23
Making Indirect Comparisons of Area.....	24
Measuring Area with Nonstandard Units.....	25
Measuring Area with Unit Squares.....	26
Measuring Area with Square Inches.....	27
Measuring Area with Square Centimeters.....	28
Using a Grid to Measure Area.....	29
Using Multiplication to Find the Area of Rectangles.....	30
Writing Equations to Represent the Area of Rectangles.....	31
Using Side Lengths to Indirectly Measure the Area of Rectangles.....	32
Using a Ruler to Indirectly Measure the Areas of Rectangles.....	33
Measuring Area with Square Feet.....	34
Measuring Area with Square Meters.....	35

Topic 3: Exploring Multiplication and Division Strategies

ST Math Objectives: Multiplication Facts and Strategies, Division Facts and Strategies, Properties of Multiplication

TEKS: 1.1.D 3.1.A 3.1.B 3.1.C 3.1.D 3.1.E 3.1.F 3.1.G 3.4.E 3.4.F 3.4.G 3.4.H 3.4.J 3.4.K 3.5.B 3.5.D 3.6.C 3.6.D 3.8.A 3.8.B

ELPS: 1.A 1.B 1.E 2.B 2.C 2.D 2.E 2.F 3.A 3.E 3.F 3.G 4.A 4.D 4.E

Modeling and Solving Multiplication Problems: Product Unknown.....	37
Modeling and Solving Multiplication Problems: Factor Unknown.....	38
Modeling and Solving Division Problems: Number of Groups Unknown.....	39
Modeling and Solving Division Problems: Group Size Unknown.....	40
Modeling and Solving Division Problems: Unknown Dividend or Divisor.....	41
Using Multiplication to Solve Problems Involving a Scaled Pictograph.....	42
Using Known Facts to Multiply Efficiently.....	43
Using Grouping Strategies to Multiply Efficiently.....	44
Relating Fours and Eights Multiplication Facts.....	45
Introducing the Distributive Property of Multiplication.....	46
Using Area Models to Represent Multiplication.....	47
Using Compensation Strategies to Multiply Efficiently.....	48
Exploring Patterns and Related Facts in a Multiplication Table.....	49
Exploring More Patterns in a Multiplication Table.....	50
Thinking Flexibly to Solve Word Problems Involving Multiplication and Division.....	51

Topic 4: Discovering Perimeter and Exploring Area

ST Math Objectives: Area and Perimeter, Shape Attributes, Multiplication and Area

TEKS: 3.1.A 3.1.B 3.1.C 3.1.D 3.1.E 3.1.F 3.1.G 3.4.A 3.4.K 3.6.A 3.6.B 3.6.C 3.6.D 3.7.B

ELPS: 1.A 1.B 1.C 1.E 2.A 2.B 2.C 2.E 2.F 3.A 3.E 3.F 3.G 3.H 4.A 4.D 4.E

Identifying Parallel Sides in Shapes.....	53
Using Attributes to Build and Identify Quadrilaterals.....	54
Using String to Measure Perimeter.....	55
Using Side Lengths to Measure Perimeter.....	56
Strategically Calculating Perimeter.....	57
Using Perimeter to Find Missing Side Lengths of Polygons.....	58
Relating Perimeter and Area.....	59
Exploring a Change in Perimeter or Area of a 2-D Shape.....	60
Solving Two-Step Problems Involving Perimeter and Area of Rectangles.....	61
Using Area to Find Missing Side Lengths of Rectangles.....	62
Finding the Area of Rectilinear Shapes.....	63
Using a Grid to Find the Area of Rectilinear Shapes.....	64
Using Side Lengths to Find the Area of Rectilinear Shapes.....	65
Solving Word Problems Involving the Area of Rectilinear Shapes.....	66

Topic 5: Extending Multiplication and Division Strategies

ST Math Objectives: Multiplication and Division Facts, Multiplication as Comparison, Solve Two-Step Problems

TEKS: 3.1.A 3.1.B 3.1.C 3.1.D 3.1.E 3.1.F 3.1.G 3.4.E 3.4.F 3.4.G 3.4.I 3.4.K 3.5.B 3.6.C 3.6.D 3.8.A 3.8.B

ELPS: 1.A 1.B 1.C 1.D 1.E 1.F 2.A 2.B 2.C 2.D 2.E 2.F 3.A 3.C 3.E 3.F 3.G 3.H 4.A 4.B 4.C 4.D 4.E 4.F

Partitioning Rectangles to Calculate Products	68
Introducing Parentheses as Grouping Symbols.....	69
Generating Multistep Expressions With and Without Parentheses.....	70
Using Divisibility Rules to Identify Evens and Odds.....	71
Exploring the Associative Property of Multiplication.....	72
Using the Associative Property to Multiply One-Digit Numbers by Multiples of 10	73
Using the Associative Property of Multiplication Strategically.....	74
Writing Equations to Solve Multiplication and Division Problems.....	75
Representing Two-Step Multiplication and Division with Array Models	76
Exploring the Inverse Relationship Between Multiplication and Division.....	77
Representing Two-Step Multiplication and Division with Strip Diagrams.....	78
Representing Two-Step Problems with Single Equations.....	79
Using Multiplication and Division to Complete the Key on Pictographs.....	80
Modeling and Solving Open-Ended Multiplication and Division Problems.....	81
Using Place Value Strategies to Find the Area of Rectangles.....	82
Using Area Models to Multiply One-Digit by Two-Digit Numbers	83
Connecting Area Models to the Standard Algorithm.....	84
Applying the Standard Algorithm to Multiply Two-Digit Numbers	85
Solving Open-Ended Problems with the Standard Algorithm.....	86
Modeling and Solving Multiplication and Division Problems Efficiently.....	87

Topic 6: Extending Place Value and Adding and Subtracting Efficiently

ST Math Objectives: Place Value to 100,000, Addition and Subtraction within 1000 Strategies, Composing and Decomposing within 1000

TEKS: 3.1.A 3.1.B 3.1.C 3.1.D 3.1.E 3.1.F 3.1.G 3.2.A 3.2.B 3.2.C 3.2.D 3.4.A 3.4.B 3.5.A 3.5.C

ELPS: 1.A 1.B 1.D 1.E 1.F 2.A 2.B 2.C 2.D 2.E 2.F 3.A 3.B 3.C 3.D 3.E 3.F 3.G 3.H 4.A 4.D 4.E

Representing Numbers to 100,000 with Base Ten Block Relationships.....	89
Using Place Value to Name and Write Numbers to 100,000	90
Using Expanded Notation to Name and Write Numbers to 100,000	91
Representing Multiplication Relationships Between Place Values	92
Using the Number Line to Find Nearby Numbers Within 100,000	93
Comparing Numbers Within 100,000	94

Rounding to the Nearest 10	95
Rounding to the Nearest 100.....	96
Using Rounding to Estimate the Total.....	97
Using Sequential Strategies to Add and Subtract Three-Digit Numbers	98
Using Decomposition Strategies to Add and Subtract Three-Digit Numbers.....	99
Using Partial Sums to Add Three-Digit Numbers.....	100
Solving Word Problems Involving Addition and Subtraction of Three-Digit Numbers.....	101
Using Estimation to Solve Three-Digit Addition and Subtraction Problems.....	102
Solving Two-Step Word Problems Involving Addition and Subtraction of Three-Digit Numbers.....	103
Using Estimation to Solve Two-Step Word Problems Involving Three-Digit Addition and Subtraction	104
Choosing Strategies to Flexibly Add and Subtract Three-Digit Numbers	105

Topic 7: Discovering Fractions

ST Math Objectives: Fraction Concepts, Fractions on the Number Line, Number Patterns

TEKS: 3.1.A 3.1.B 3.1.D 3.1.E 3.1.F 3.1.G 3.3.A 3.3.B 3.3.C 3.3.D 3.3.E 3.6.E 3.7.A

ELPS: 1.A 1.B 1.C 1.E 2.A 2.B 2.C 2.D 2.E 2.F 3.A 3.F 4.A 4.D 4.E 4.F

Partitioning Area Models into Equal Parts	107
Analyzing the Meaning of One-Half.....	108
Introducing the Unit Fraction	109
Defining the Whole to Name and Iterate Unit Fractions.....	110
Iterating Unit Fractions to Create Fractions.....	111
Partitioning a Whole to Create Fractions	112
Iterating Unit Fractions to Create the Whole	113
Decomposing and Composing Fractions with Visual Models.....	114
Exploring Fractions Involving Discrete Sets.....	115
Exploring Fractions Involving Number Lines.....	116
Locating Fractions on a Number Line.....	117
Relating Different Fraction Models.....	118

Topic 8: Exploring Fraction Thinking

ST Math Objectives: Fraction Equivalence and Ordering, Fractions on the Number Line, Fraction Concepts

TEKS: 3.1.A 3.1.B 3.1.C 3.1.D 3.1.E 3.1.F 3.1.G 3.3.A 3.3.B 3.3.C 3.3.D 3.3.F 3.3.G 3.3.H 3.6.E 3.7.A

ELPS: 1.A 1.B 2.B 2.C 2.D 2.E 3.A 3.B 3.C 3.D 3.F 4.A 4.D 4.E

Writing One Whole as a Fraction.....	120
Exploring Equivalent Fractions for One-Half	121
Using Patterns to Make Equivalent Fractions.....	122
Generating Equivalent Fractions on a Number Line.....	123
Using Equivalent Fractions to Solve Word Problems.....	124
Comparing Fractions with Common Denominators	125
Comparing Unit Fractions	126
Comparing Fractions with Common Numerators.....	127
Using Benchmarks to Order Fractions on a Number Line	128

Topic 9: Exploring Measurement

ST Math Objectives: Time to the Minute, Intervals of Time, Weight and Volume

TEKS: 3.1.A 3.1.B 3.1.C 3.1.D 3.1.E 3.1.F 3.1.G 3.3.H 3.4.A 3.4.K 3.5.E 3.6.A 3.7.A 3.7.D 3.7.E 3.8.A 3.8.B

ELPS: 1.A 1.B 1.C 1.D 1.E 2.A 2.B 2.C 2.D 2.E 2.F 3.A 3.B 3.D 3.E 3.F 4.A 4.B 4.C 4.D 4.E 4.F

Measuring Length with More Precision	130
Strategically Comparing Fractions	131
Measuring Distance Traveled.....	132
Using a Dot Plot to Organize and Display Length Data	133
Using a Dot Plot to Interpret Length Data	134
Collecting Length Data and Displaying on a Dot Plot	135
Analyzing Length Data on a Dot Plot	136
Identifying 3-D Shapes by Their Attributes	137
Introducing Liquid Volume.....	138
Solving Problems Involving Liquid Volume.....	139
Introducing Liquid Volume in Customary Units	140
Introducing Weight	141
Estimating and Solving Measurement Problems in Context.....	142
Using Tables to Represent Additive and Multiplicative Measurement Relationships.....	143

Topic 10: Deepening Financial Literacy

ST Math Objectives: Money with Coins and Bills, Addition and Subtraction within 1000 Strategies, Solve Two-Step Problems

TEKS: 3.1.A 3.1.B 3.1.E 3.1.F 3.1.G 3.4.A 3.4.C 3.4.K 3.5.C 3.5.E 3.9.A 3.9.B 3.9.C 3.9.D 3.9.E 3.9.F

ELPS: 1.A 1.F 2.A 2.C 2.D 2.E 3.A 3.C 3.E 3.F 3.H 4.A 4.B 4.C 4.D 4.E

Finding the Value of Collections of Coins and Bills	145
Representing a Given Amount with Coins and Bills.....	146
Solving Addition and Comparison Problems with Money	147
Solving Subtraction Problems by Making Change.....	148
Identifying Factors that Affect Income.....	149
Identifying Benefits and Strategies for Saving Money.....	150
Exploring Responsible Credit Use and Paying Interest.....	151
Exploring Decisions About Planned and Unplanned Uses of Money	152
Exploring How Availability Affects the Price of Resources.....	153

Topic 11: Investigating Data

ST Math Objectives: Line Plots, Scale and Measurement in Graphing, Number Patterns

TEKS: 3.1.A 3.1.B 3.1.C 3.1.D 3.1.E 3.1.F 3.1.G 3.7.C 3.8.A 3.8.B

ELPS: 1.A 1.E 2.B 2.E 2.F 3.A 3.B 3.C 3.E 3.F 3.G 4.A 4.C 4.D 4.E

Starting a Data Investigation	155
Completing a Data Investigation.....	156
Revisiting a Data Investigation	157
Using Surveys to Collect and Display Data in Scaled Bar Graphs.....	158
Collecting Survey Data to Display in Scaled Pictographs and Bar Graphs.....	159
Displaying Survey Data in Scaled Pictographs and Bar Graphs... 160	
Interpreting Scaled Pictographs and Bar Graphs to Solve One- and Two-Step Problems.....	161
Relating Analog Clocks, Number Lines, and Time	162
Modeling and Solving Word Problems Involving Time.....	163

Topic 1

Discovering Multiplication and Division

Recommended ST Math Objectives:

Multiplication Concepts

Division Concepts

Multiplication and Division Relationships

Name: _____

Date: _____

Exploring Equal Groups

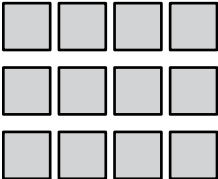
1  Write an equation to match the model.

$$\square + \square + \square = \square$$

2 Is 7 an odd number or an even number?

Draw a picture to show your thinking.



3 You have 12 triangles. Draw 2 different ways that you can put them into equal groups.

4 You have 18 cookies that you are putting in boxes for the school bake sale. Each box needs to have the same number of cookies. If you have 6 boxes, how many cookies can you put in each box? Explain your thinking.

Did you show your thinking?



Name: _____

Date: _____



Jaymie

Using Equal Groups to Find the Total

1

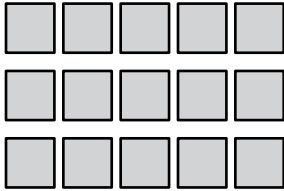

How many squares are in this model?

Is the number of squares odd or even?

How do you know?



2

The glue sticks in Jaymie's classroom come in packs of 4. How many glue sticks could Jaymie's classroom have?

Explain your thinking.



3

If Jaymie's class has 30 erasers, could the erasers come in packs of 3?

Show your work.



4

Jaymie has 8 packs of markers for the school supply sale. Each pack of markers contains 10 markers. How many total markers are there? Show your work.

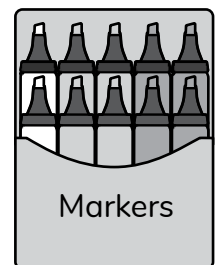

Did you show your thinking?



Name: _____

Date: _____



Writing Repeated Addition Equations to Model Equal Groups

- 1 Use the number line to find the difference of $43 - 15$.

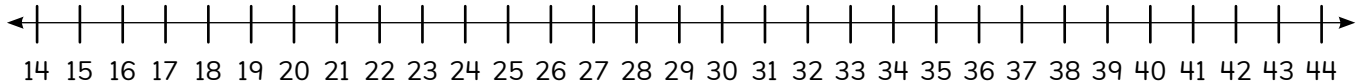

- 2 Count by 5s.

55 60 65

- 3 a) There are 6 tables in the library at Jaymie's school.
If there are 3 students at each table, how many students are in the library?

- b) More students enter the library. Now there are 5 students at each table. How many students are in the library now?

- 4 Brian's classroom has 8 tables. Each table has 3 students.
How many students are in Brian's class? Explain your thinking.

Did you explain your thinking?



Name: _____

Date: _____



Introducing Multiplication

- 1 Solve.

$$24 - 8 = \square$$

$$37 - 30 = \square$$

- 2

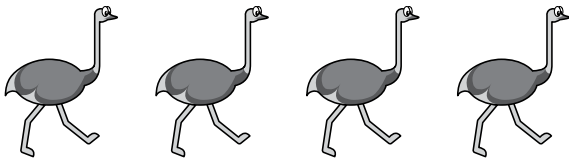

Write an equation to show how many shoes these ostriches need.

- 3



Circle the expressions that represent the shoes the dogs need.

$$4 + 4 + 4 + 4 + 4$$

$$5 + 5 + 5 + 5 + 5$$

$$5 \times 4$$

$$2 \times 10$$

- 4

Jaymie helped her art teacher set up the art room for her school's Painting Club. She put 3 jars of paint on the table. This expression represents the number of paintbrushes she put on the same table.

$$5 \times 3$$

Circle the statement that is true.

There are 5 more paintbrushes than jars of paint on the table.

There are 5 times as many paintbrushes as jars of paint on the table.

There are 5 times as many jars of paint as paintbrushes on the table.

Name: _____

Date: _____



Modeling and Solving Multiplication Problems with Equal Groups

- ① Solve.

$$19 + 9 = \square$$

The sum of 19 and 9 is an even number.

True **False**

- ② Skip count by 2.

30 32 34

- ③ Draw a creature with 3 legs. Use the creature to solve the following problems.

$$4 \times 3 = \square$$

$$5 \times 3 = \square$$

- ④ Jaymie is helping to put flowers in vases to give to the third-grade teachers for Teachers' Day. She knows there are 5 teachers. She wants to put 6 flowers in each vase. Draw a picture to model this story. Then, write an equation to show how many flowers Jaymie will need to make the gifts.

Did you show your thinking with a drawing and an equation?



Name: _____

Date: _____

Modeling and Solving Partitive Division Problems

- ① Write four equations using the numbers 7, 8, and 15.

$$\square + \square = \square$$

$$\square - \square = \square$$

$$\square + \square = \square$$

$$\square - \square = \square$$

- ② Is $82 < 63$? **Yes** **No**

- ③ If the trapezoids are shared equally, show how many are in each group.

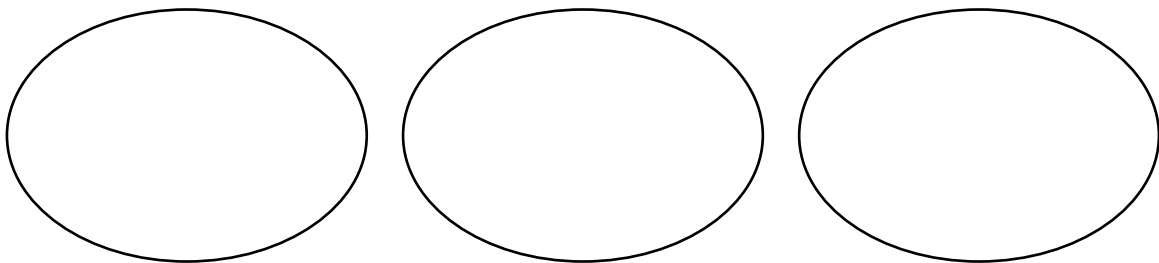
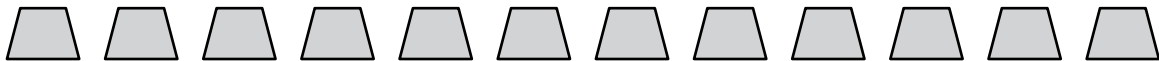

- ④ These critters have 24 squares to share. How many squares will each critter get if the squares are shared equally? Draw a picture to model this story. Then, write an equation to show how many squares each critter will receive.

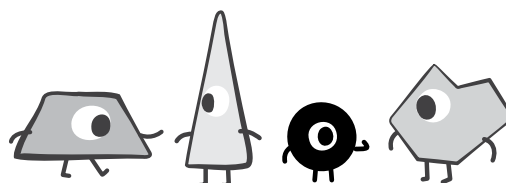

Did you show your thinking with a drawing and an equation?



Name: _____

Date: _____

Modeling and Solving Quotitive Division Problems

1 Write the missing number. $9 + 9 = \square + 11$

2 Use the number line to find the sum of $62 + 23$.

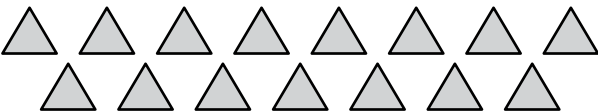

3  How many groups of 5 can be made from these triangles?

4 There are 20 squares. Each critter gets 4 squares. How many critters are there?



Draw a picture to model the story.

Write an equation and solve.

5 On their field trip to the zoo, 27 students decide to ride the boat ride. If 3 students can fit in each boat, how many boats will be needed so everyone can ride? Draw a picture to model this story. Then, write an equation to show how many boats will be needed. Explain your thinking.

Did you show your thinking?



Name: _____

Date: _____



Interpreting Division Situations

- ① Circle the correct time.

11:00

11:55

10:55

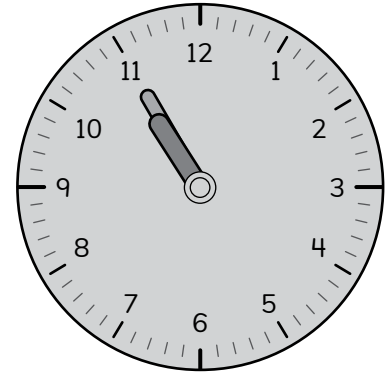

- ② Finish each statement.

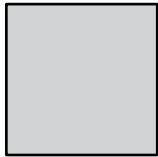

One square has sides.

Two squares have sides.

Three squares have sides.

- ③ Solve by drawing a picture to model the equation.

$$12 \div 3 = \boxed{}$$

- ④ Jaymie is refilling the pencils in her classroom. She has 30 pencils and 6 tables that need pencils. If every table should have the same number of pencils, how many pencils does Jaymie need to put at each table? Write an equation and solve.

Name: _____

Date: _____



Using Arrays to Organize Equal Groups

- 1 Write the equation represented by the number line.

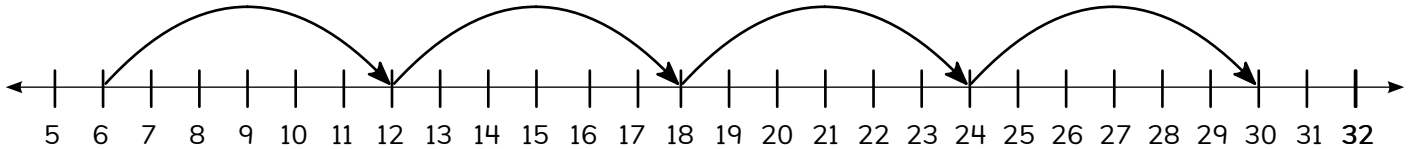

- 2 Write a multiplication expression that represents this array.

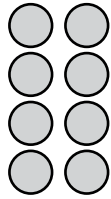

- 3 Make an array to represent 10×10 .

- 4 Jaymie is helping to set up chairs for her school's art show. She puts the chairs in an array that has 4 rows with 9 chairs in each row. How many chairs does Jaymie use? Draw an array and write an equation to support your answer.

Did you show your thinking with an array and an equation?



Name: _____

Date: _____



Modeling and Solving Word Problems Involving Arrays

Hannah

- 1 Write the multiplication equation represented by the repeated-addition expression.

$$4 + 4 + 4 + 4 + 4 + 4$$

$$\square \times \square = \square$$

- 2 Circle the correct length for the average pencil.

20 meters

20 centimeters

- 3 Hannah has 12 tomato seeds she wants to plant. Draw how she could plant them in equal rows.

Write an equation to match.



- 4 Write an equation for how many squash are planted here.



- 5 Hannah is planting pumpkin seeds with her dad on their farm. She has 18 seeds. Draw 2 different arrays she could use to plant the seeds. Write an equation to match each array.

Name: _____

Date: _____



Hannah

Exploring the Commutative Property of Multiplication

- 1 Circle the expressions that represent the amount of tentacles.



$3 + 8$

3×8

$8 + 8 + 8$

$3 + 3 + 3$

- 2 Write 2 equations that represent the number of circles in this array.

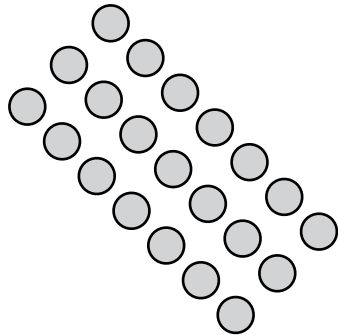

- 3 How many strawberries are in this array? Solve with an equation.

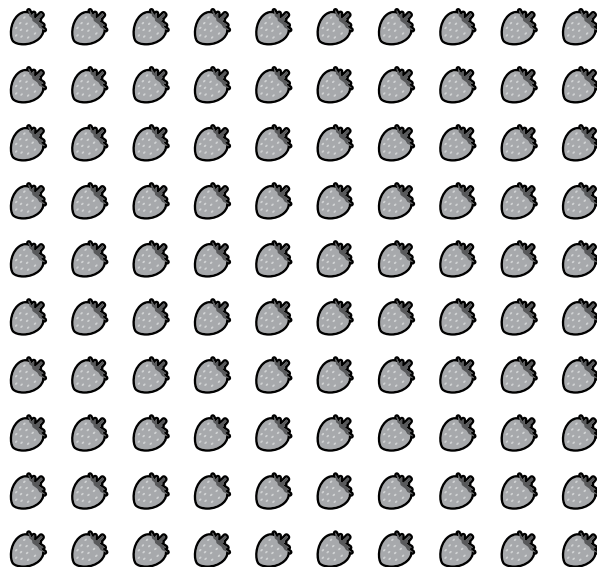

Did you write an equation?



Name: _____

Date: _____



Hannah

Using the Commutative Property of Multiplication Strategically

- 1 Write the 3 numbers that come next as you count.

267, 268, 269, , ,

- 2 Continue the pattern.

105, 110, 115, , ,

- 3 Which expression would you prefer to solve: 9×10 or 10×9 ?

Explain your thinking.



- 4 Which one does not belong?

Explain your thinking.



		18	6×3	3×6
--	--	----	--------------	--------------

- 5 At the farmers market, Hannah's dad has 8 boxes of apples to sell. Each box has 6 apples. How many apples will Hannah's dad sell if he sells all of the apples he has? Write an equation to represent the problem.

Did you show your thinking with an equation?



Name: _____

Date: _____



Hannah

Using Patterns to Multiply

- ① What is the name of this shape? How do you know?

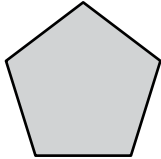

- ② How many of the critters could equally share the blocks? Show how you know.

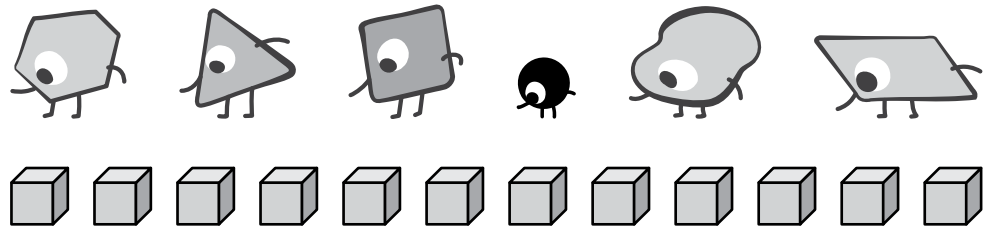

- ③ Draw a line to match equations with the same product.

24×1	7×1
1×7	10×2
1×20	2×12

- ④ Can you divide 80 into 10 equal groups? Why or why not?

- ⑤ Jaymie is helping to finish setting up 10 chairs for a performance at school. What are two different ways Jaymie could arrange the chairs into equal groups? Show how you know.

Did you show how you know?



Name: _____

Date: _____



Jaymie

Using Multiplication and Division Patterns to Solve Equal-Group Problems

- 1 About how many students would be in 2 third-grade classes?

5 students 50 students 500 students

- 2 Write 5×7 as a repeated-addition equation.

- 3 Circle True or False for each statement, and then explain your answer.

a) 26 crayons can be put into 8 equal groups.

True False

b) 24 crayons can be put into 6 equal groups.

True False

- 4 Jaymie organizes the markers in the art bin so there are 6 markers in each group. Her teacher reorganizes the markers so there are 3 markers in each group. There are fewer than 20 markers in the art bin. How many markers might be in the art bin? Explain your thinking.

Did you explain
your thinking?



Name: _____

Date: _____



Hannah

Using Multiplication and Division to Unlock the Barn

- 1 How could you split 15 pencils into 3 equal groups?

- 2 Put an X on the third square. Fill in the fifth square.

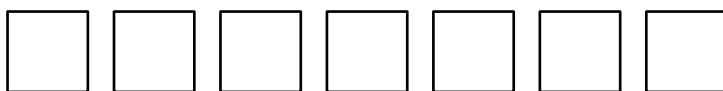

- 3 Use the pictograph to answer the following questions.

- a) Hannah says that she and her dad sold 3 ears of corn at the farmers market on Tuesday. Is Hannah correct?

Yes No

- b) How much squash was sold at the farmers market on Tuesday? Write an equation and show your thinking.

Tuesday's Farmers Market Sales

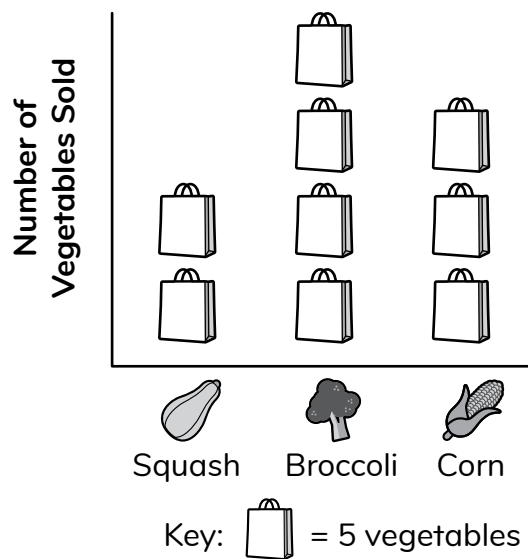

- 4 Each month, Hannah puts the sunflowers that she and her dad grow into bunches to sell at the farmers market. Each bunch has 6 sunflowers, and she would like to make 7 bunches. How many sunflowers does Hannah need? Write an equation and solve.

Did you write an equation to explain your thinking?



Topic 2

Exploring Area

Recommended ST Math Objectives:

Multiplication and Area

Area and Perimeter

Properties of Multiplication

Name: _____

Date: _____



Superimposing to Directly Compare Area

- 1 Write the number that is 30 more than 73.
- 2 Write a repeated-addition expression that has the same value as the expression 4×6 .
- 3 Describe something that you learned during today's lesson.
Use the words *area* and *compare* in your description.
- 4 Jaymie bought 3 bags of erasers at the school book fair. Each bag held 6 erasers.
How many erasers did she buy?

Name: _____

Date: _____



Measuring Area with Nonstandard Units

① Solve.

$$8 \times 5 = \square$$

$$4 + 5 + 6 + 9 + 5 = \square$$

② What is something new you know about area after today's lesson?

③ Arman wants to design a tile mosaic for his mother. He buys 6 boxes of tiles. Each box has 8 tiles. How many tiles does Arman have for his mosaic?

Name: _____

Date: _____



Measuring Area with Unit Squares

- 1 Arman designed a mosaic with triangles and rhombuses. He used 8 triangles in his mosaic. This expression represents the number of rhombuses he used in the same mosaic.

$$6 \times 8$$

Circle the statement that is true.

- There are 6 times as many triangles as rhombuses in his mosaic.**
There are 6 more triangles than rhombuses in his mosaic.
There are 6 times as many rhombuses as triangles in his mosaic.

- 2 a) Draw an array for 3×8 . b) How many objects are in your array?



- 3 Circle the critter you agree with. Show your thinking.

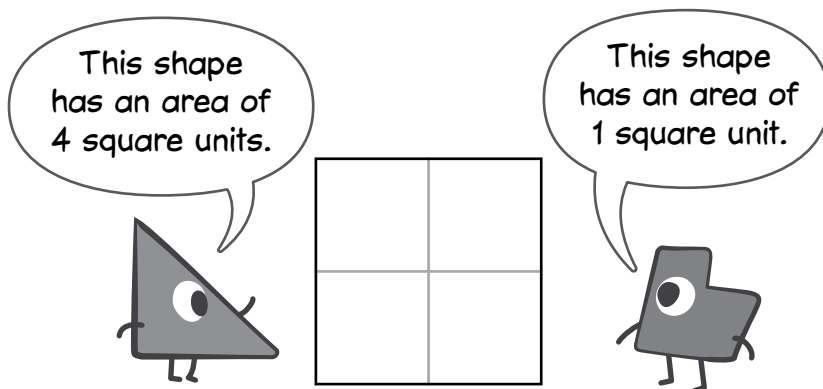

- 4 Arman is designing another mosaic. His design has 6 rows of 10 square tiles. How many square tiles does Arman's design use?

Name: _____

Date: _____



Measuring Area with Square Inches

- 1 Put an X on the shape that does not belong.



Explain your thinking.

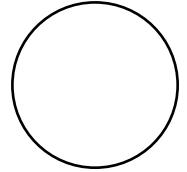
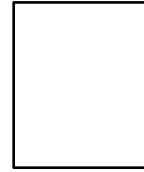

- 2 Does $4 \times 5 = 5 \times 4$? Why or why not?

- 3 What is the area of the shape?

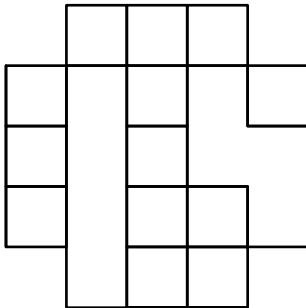

Explain your thinking.



square units

- 4 Arman uses 72 square inch tiles to create his next mosaic design. Arman says that if he uses square centimeter tiles to create the same design, he will need more than 72 tiles. Do you agree? Explain your reasoning.

Did you explain your reasoning?



Name: _____

Date: _____



Measuring Area with Square Centimeters

1 Which job would require you to measure area?

painting a wall

selling lemonade

2 Solve.

$$7 \times 4 = \square$$

3 What is the area of the shape?

square units

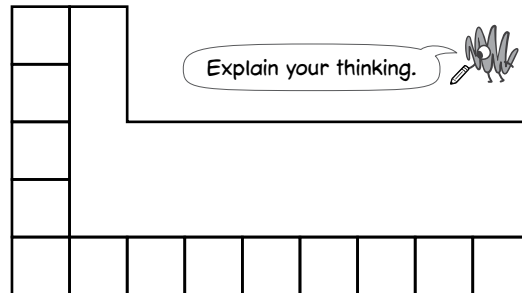

4 Jaymie is helping her teacher make bags of cookies for a class party. Each bag needs 4 cookies in it, and Jaymie will make 8 bags. How many cookies will Jaymie use?

Name: _____

Date: _____

Using a Grid to Measure Area

- 1 Which unit of measure would you use to find the area of your Playbook?

inches

square inches

- 2 Continue the pattern.

6, 12, 18,

, ,

- 3 a) What is the area of the rectangle?

square units

- b) Circle the phrase that will correctly complete the sentence.

The area of the trapezoid is _____ the area of the rectangle.

less than

greater than

equal to

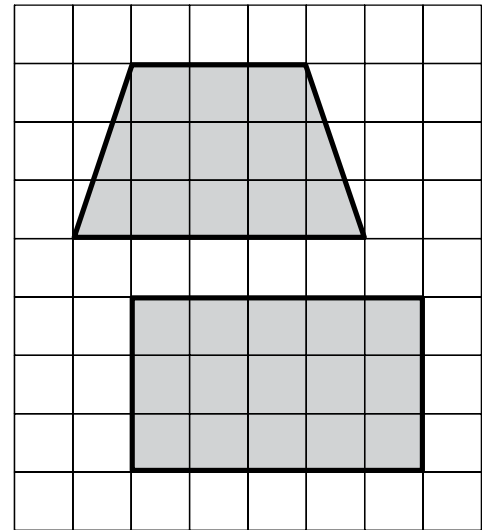

- 4 Rectangle A can be covered by 6 rows with 4 square units in each row. Rectangle B can be covered by 7 rows with 3 square units in each row. Which rectangle has a smaller area? Explain your thinking.

Did you explain your reasoning?



Name: _____

Date: _____



Using Multiplication to Find the Area of Rectangles

- 1 Continue the pattern.

8, 16, 24, , ,

- 2 About how long would it take you to brush your teeth?

20 minutes 2 minutes 2 hours

- 3 a) What is the area of this shape?

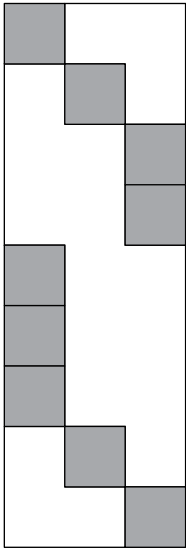

- b) Explain how you found the area.

- 4 Hannah is preparing a field to grow pumpkins. She has dug 3 rows of holes with 8 holes in each row to put seeds into. How many holes has she dug? Explain your thinking.

Did you explain
your reasoning?



Name: _____

Date: _____



Writing Equations to Represent the Area of Rectangles

- 1 Write a repeated-addition expression that has the same value as the multiplication expression 3×9 .

- 2 Write the total value of each group of coins.

7 dimes

5 nickels

3 quarters

3 $4 \times 4 = 16$

$3 \times 9 = 27$

$6 \times 3 = 18$

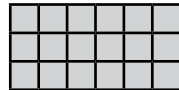
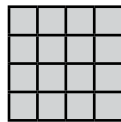

a) Match each equation to a rectangle.

b) Circle the rectangle that matches the equation $9 \times 3 = 27$.

- 4 Arman is designing a mosaic out of square tiles. He has a total of 24 tiles. If he uses all 24 tiles in the design, what are 2 different rectangles he could make? Write an equation to describe each design option. Explain your thinking.

Did you explain your reasoning?



Name: _____

Date: _____



Jaymie

Using Side Lengths to Indirectly Measure the Area of Rectangles

- 1 Jaymie measured the area of the dry-erase board in her classroom. Which area measurement most likely matches what Jaymie measured?

24 feet 24 square feet 24 inches

- 2 Solve.

$$9 \times 9 = \square$$

- 3 a) What is the area of the rectangle?

- b) Write an equation to show how you found the area of the rectangle.

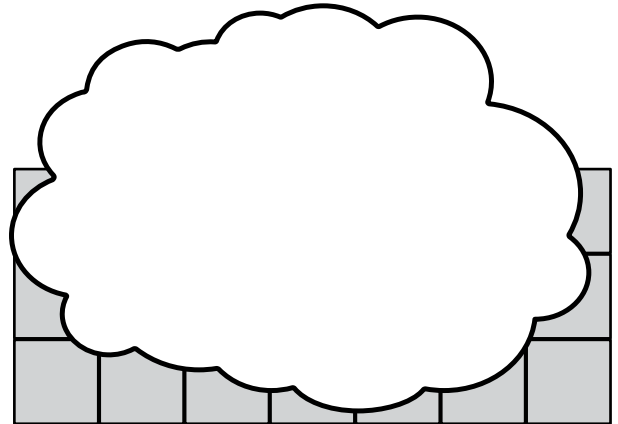

- 4 If the art teacher has 9 packs of markers, and each pack has 8 markers, how many markers does the art teacher have? Explain your thinking.

Did you explain your reasoning?



Name: _____

Date: _____



Using a Ruler to Indirectly Measure the Areas of Rectangles

- 1 Arman drew an array that has 12 objects. How many rows and how many objects in each row could his array have?

Select ALL that apply.



- 6 rows, 2 objects in each row 10 rows, 2 objects in each row 4 rows, 3 objects in each row

- 2 Write a multiplication expression that has the same value as the repeated-addition expression $5 + 5 + 5 + 5$.

- 3 a) Create a rectangle with an area of 16 square centimeters.
b) Write an equation to match your rectangle.



- 4 Arman has 45 tiles for his next mosaic design. If he splits the tiles into groups of 5, how many groups of tiles will he make? Explain your thinking.

Did you explain your reasoning?



Name: _____

Date: _____



Measuring Area with Square Feet

- ① Solve.

$$4 + 6 + 9 + 7 + 1 + 5 + 3 = \boxed{}$$

- ② What unit of measure would you use to find the height of a house?

feet

centimeters

- ③ Aleki wants to paint some walls in his living room. One of the walls is 7 ft long and 8 ft high, and the other wall is 6 ft long and 8 ft high.

a) What are the areas of the walls?

b) If Aleki has enough paint to cover 100 sq. ft, does he have enough paint for both walls?



Explain your thinking.

- ④ A critter has a garden in the shape of a square that measures 8 feet on each side. What is the area of the garden? Draw a picture to show your thinking.

Did you draw a picture to show your thinking?



Name: _____

Date: _____



Measuring Area with Square Meters

- 1 Show how to put 24 markers into 3 equal groups.

- 2 Connect the measurement to its correct unit:

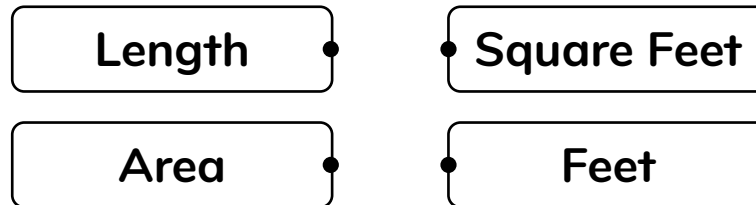

- 3 Hannah is planning out the fields that she and her dad will be planting in this year. She wants the sunflower field to have the dimensions of 4 meters by 9 meters. What will the area of the sunflower field be?

- 4 Hannah also wants a tulip field that is 8 meters long and 7 meters wide. What will the area of the tulip field be?

- 5 The basketball court at Aleki's school has side lengths of 9 feet and 8 feet. What is the area of the basketball court? Explain your thinking.

Did you explain your reasoning?



Topic 3

Exploring Multiplication and Division Strategies

Recommended ST Math Objectives:

Multiplication Facts and Strategies

Division Facts and Strategies

Properties of Multiplication

Name: _____

Date: _____

Modeling and Solving Multiplication Problems: Product Unknown

- ① What is the value of the 5 in each number?

152

395

520

- ② Estimate the sum of $78 + 19 + 9$.

- ③ a) Write an equation to represent each bar model.

$$\boxed{} \times \boxed{} = \boxed{}$$

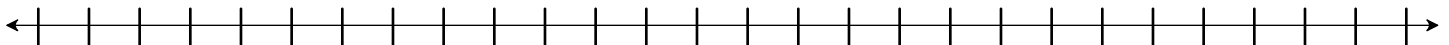

$$\boxed{} \times \boxed{} = \boxed{}$$

- b) What do you notice about the 2 equations?

- ④ This critter has 9 bags of tacos. Each bag contains 5 tacos. How many tacos does the critter have? Show how you found the answer.

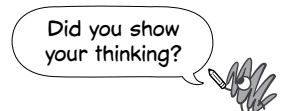
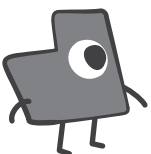

Name: _____

Date: _____



Jaymie

Modeling and Solving Multiplication Problems: Factor Unknown

① About how long would it take to watch a movie?

2 minutes

2 days

2 hours

② Solve.

$$8 \times 8 = \square$$

③ a) Fill in the missing factor with 2, 5, or 7 and solve the equation.

$$\square \times 4 = \square$$

b) Show how many groups and how many in each group are represented by the equation.

④ Jaymie has some boxes of markers. Each box contains 6 markers. If Jaymie has a total of 42 markers, how many boxes of markers are there? Show how you found the answer.

Did you show
your thinking?



Name: _____

Date: _____



Modeling and Solving Division Problems: Number of Groups Unknown

- 1 What is the area of the rectangle?

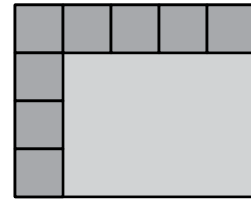

- 2 Write a multiplication equation for the array.

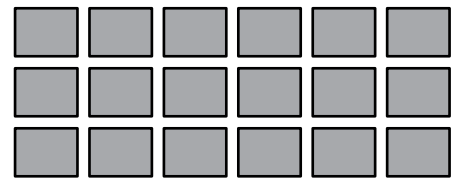

- 3  I have 36 markers. I want to put 9 markers on each table. How many tables will I use?

a) Draw a strip diagram to represent the problem.

b) Write 2 equations to represent the problem.

- 4 Jaymie has 11 packs of erasers with 4 erasers in each pack. How many erasers does she have in total?

Name: _____

Date: _____



Aleki



Vivi

Modeling and Solving Division Problems: Group Size Unknown

- 1 Aleki arrived at band practice at 4:00. He finished band practice at 6:00 and went home. Do you think these times are a.m. or p.m.?

Explain your thinking. 
- 2 If $6 \times 2 = 12$, what is the value of $12 \div 2$?
- 3 Vivi has 28 red beads. She wants to use them to make 4 necklaces that each have the same number of beads. How many beads can she put on each necklace? Show your thinking with a strip diagram.
- 4 Vivi has 36 blue beads. She wants to use them to make bracelets so that each bracelet has the same number of beads. Can she make 9 bracelets? Show how you found the answer.

Did you show your thinking?



Name: _____

Date: _____



Modeling and Solving Division Problems: Unknown Dividend or Divisor

- 1 What is the value of the set of coins?



Write the value using the dollar sign.

Write the value using the cent sign.

- 2 Does this model represent $7 \div 4 = \square$?

Yes

No

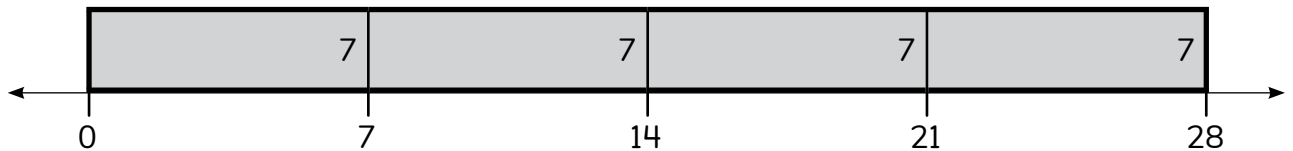
 =

What is an equation that does represent the model?



- 3 Vivi had some stickers. She shared them equally between 5 friends. Each friend got 3 stickers. How many stickers did Vivi start with? Write an equation with a box for the unknown and then solve.

Name: _____

Date: _____

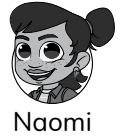

Naomi

Using Multiplication to Solve Problems Involving a Scaled Pictograph

- 1 Continue the pattern.

28, 30, 32, , ,

- 2 What time is shown on the clock?

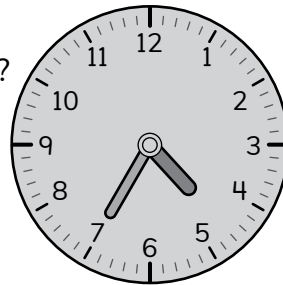

- 3 Naomi found 21 sea stars on Sunday.

- a) Write an equation to help you determine how many symbols you will need to draw to represent the number of sea stars. Draw an empty box to represent the data you are missing.



Blue Mussel



Green Sea Urchin



Hermit Crab



Sea Star

Tide Pools on Sunday

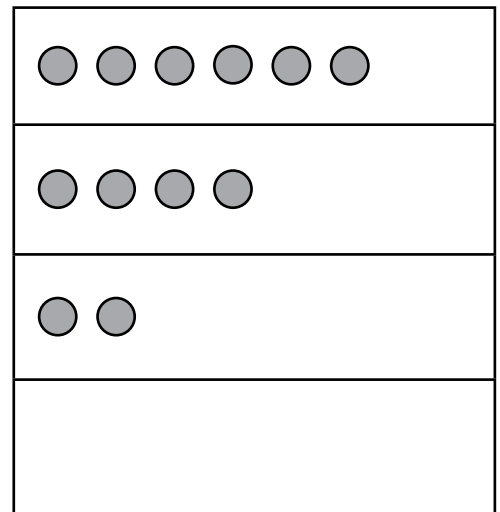

Key: = 3 ocean creatures

- b) Complete the pictograph to show the number of sea stars.
- c) How many more sea stars than blue mussels did Naomi find?

- 4 Naomi and her friend visited 3 tide pools on Monday. They saw 9 hermit crabs in each tide pool. How many hermit crabs did they see? Show how you found the answer.

Did you show your thinking?



Name: _____

Date: _____



Using Known Facts to Multiply Efficiently

1 Write the number 913 in expanded form.

2 If $5 \times 3 = 15$, what is the value of $15 \div 5$?

3 How many shoes do the creatures need?



Write an equation that matches the picture.



4 a) Solve.

$$2 \times 5 = \square \quad 4 \times 5 = \square$$

b) How does $2 \times 5 = \square$ help you solve $4 \times 5 = \square$?

5 Vivi has 4 bracelets that have 6 beads each. Naomi has 8 bracelets that have 3 beads each. Do Vivi and Naomi have the same number of beads? Show how you found your answer.

Did you show your thinking?



Name: _____

Date: _____

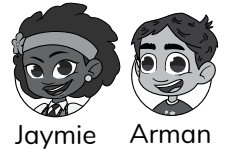

Using Grouping Strategies to Multiply Efficiently

1 What time will the clock show in 15 minutes?

- 2:25 2:30 2:10

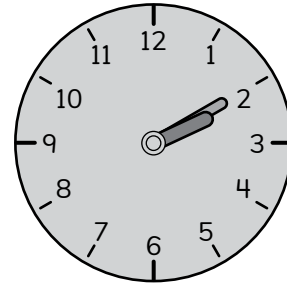

2 If it takes 8 purple beads to make a bracelet, how many purple beads are needed to make 6 bracelets?

3 What is the total?

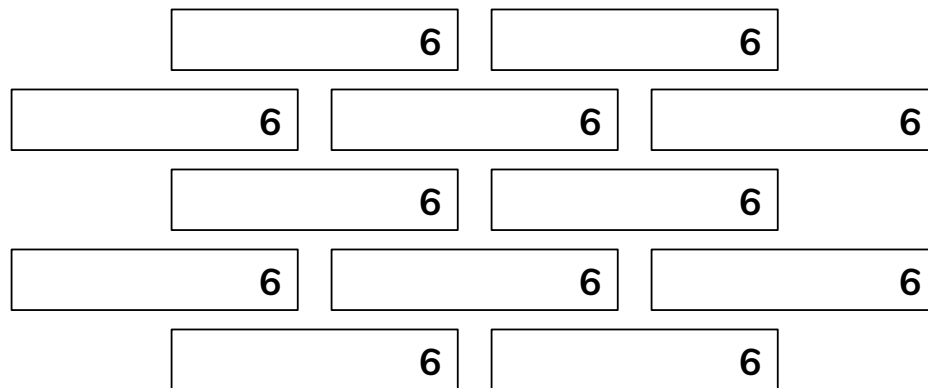

4 Jaymie has 8 packs that contain 2 pencils each. Arman has 3 packs that contain 6 pencils each. Do Jaymie and Arman have the same number of pencils? Show how you found the answer.

Did you show your thinking?



Name: _____

Date: _____



Relating Fours and Eights Multiplication Facts

① Draw 3 different quadrilaterals.

② What is the value of 3 dimes, 5 nickels, and 2 pennies?

③ $4 \times 4 = 8 \times 2$ True False

Show your thinking.



④ a) Vivi has 24 beads. She is thinking about using the beads to make 2 bracelets that each have 12 beads. What is another way Vivi could use the 24 beads to make bracelets that each have the same number of beads?

bracelets \times beads per bracelet = 24 total beads

b) Write equations for ALL the different ways Vivi could use 24 beads to make bracelets that have an equal amount of beads.

Name: _____

Date: _____



Introducing the Distributive Property of Multiplication

- 1 Write these numbers in order from greatest to least.

228 288 282

- 2 Which unit of measure would you use to record area?

square feet feet

- 3 a) Split the rectangle in a way that makes it easier for you to find its area.

- b) What is the area of the rectangle? *Show how you know.*

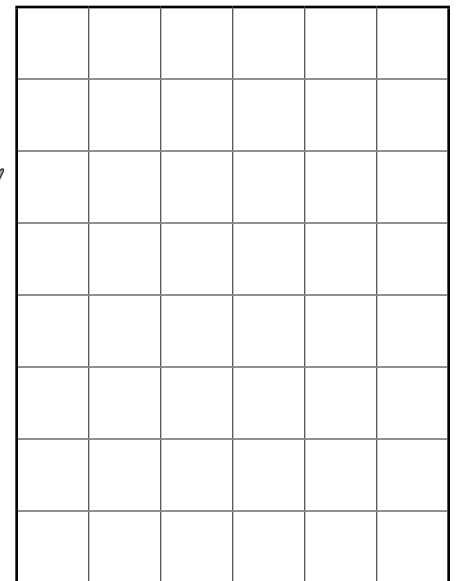

- 4 Hannah has a rectangular garden bed to plant some new vegetables in. If the total area is 36 square feet, what could the side lengths of the garden bed be? Show how you found the answer.

Did you show your thinking?

Name: _____



Date: _____



Using Area Models to Represent Multiplication

- 1 Out of the 276 stickers in a sticker collection, 258 are scratch and sniff. How many stickers are NOT scratch and sniff. *Show your thinking.* 

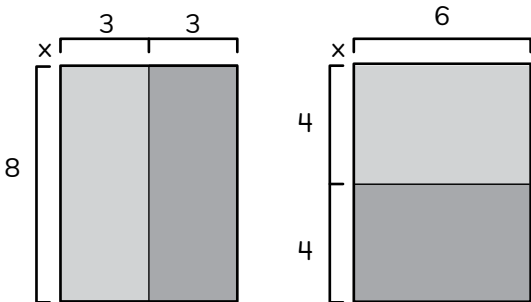
- 2 Find the product of 9×8 . *Show your thinking.* 

- 3  Do these rectangles have the same total area?
 Yes No *Show how you know.* 

- 4 Hannah planted 9 rows of flowers. In each row, there are 2 roses and 5 daisies. How many flowers did she plant?

Did you show your thinking?



Name: _____

Date: _____



Using Compensation Strategies to Multiply Efficiently

1 Which number has a 7 in the tens place?

272

720

907

2 Which number is between 65 and 89?

72

90

64

3 Naomi wants to find the product of 5×9 . How can she use 5×10 to help her find the product?

4 Use what you know about multiplying 10 to help you find the product of 9×9 .

Show your thinking.



5 Naomi's 7 cousins will attend her quinceañera. Naomi's *abuela* wants to give each cousin 6 dollars. How much money does Naomi's *abuela* need to bring to the quinceañera? Explain your thinking.

Did you explain your thinking?



Name: _____

Date: _____



Exploring Patterns and Related Facts in a Multiplication Table

- 1 Which object is a 3-D shape?

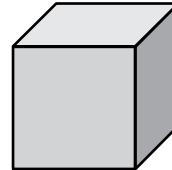
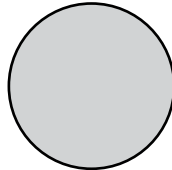

- 2 Continue the pattern. 12, 16, 20, 24, , ,

- 3 a) Complete the 2s column, and then complete the 4s column.

- b) How did the 2s column help you fill in the 4s column?

	1	2	3	4	5	6	7	8	9	10
1	1				5					10
2		4		8	10			16		20
3		6		12	15			24		30
4					20					40
5		10		20	25			40		50
6					30					60
7					35					70
8					40					80
9					45					90
10			30		50					100

- 4 Jaymie has 5 boxes of markers. Each of Jaymie's boxes contains 4 markers. Vivi has 6 boxes of markers. Each of Vivi's boxes contains 3 markers. Who has more markers? Explain your thinking.

Did you explain your thinking?



Name: _____

Date: _____



Arman

Exploring More Patterns in a Multiplication Table

1 Circle the number with the least value. **134** **143** **334**

2 What does this tool measure?

time length temperature

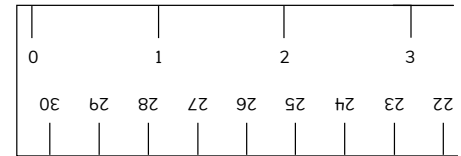

3 a) Circle a number on the table. Write 2 equations that represent that number.

$$\boxed{} \times \boxed{} = \boxed{}$$

$$\boxed{} \div \boxed{} = \boxed{}$$

x	1	2	3	4	5	6	7	8	9	10
1	1	2	3	4	5	6	7	8	9	10
2	2	4	6	8	10	12	14	16	18	20
3	3	6	9	12	15	18	21	24	27	30
4	4	8	12	16	20	24	28	32	36	40
5	5	10	15	20	25	30	35	40	45	50
6	6	12	18	24	30	36	42	48	54	60
7	7	14	21	28	35	42	49	56	63	70
8	8	16	24	32	40	48	56	64	72	80
9	9	18	27	36	45	54	63	72	81	90
10	10	20	30	40	50	60	70	80	90	100

b) Explain how the multiplication table helps you find the product of 6×8 .

4 Arman is creating a mural for his mom. The mural is in the shape of a square. He uses 7 rows of tiles and needs a total of 49 tiles to complete the mural. How many tiles are in each row? Explain your thinking.



Name: _____

Date: _____



Thinking Flexibly to Solve Word Problems Involving Multiplication and Division

1 Draw base ten blocks to represent 255.

2 Write the number nine hundred fifty-three in standard form.

3 a) If Naomi had seen 14 more shooting stars, how many more star symbols would need to be added to the pictograph?

b) How many total shooting stars would Naomi have seen? *Show your thinking.*



Key: ☆ = 7 shooting stars

4 The following image shows the fireflies Vivi found. Vivi finds 8 more fireflies. She plans to put an equal number of the new fireflies into each of the jars that already hold 3 fireflies. How many fireflies will Vivi then have in each jar? Explain your thinking.

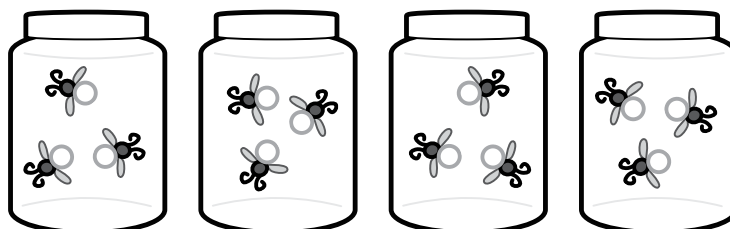

Did you explain your thinking?



Topic 4

Discovering Perimeter and Exploring Area

Recommended ST Math Objectives:

Area and Perimeter

Shape Attributes

Multiplication and Area

Name: _____

Date: _____



Identifying Parallel Sides in Shapes

1

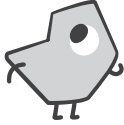

I made 8 sandwiches and used 2 slices of bread for each sandwich.
How many slices of bread did I use?

a) Draw a strip diagram to represent the situation.

b) Write an equation.

2

$$12 \times 4 = \square$$

$$4 \times 12 = \square$$

3

Circle the parallelograms.

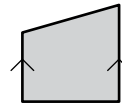
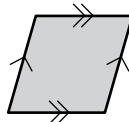
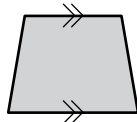
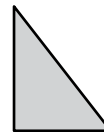
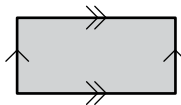
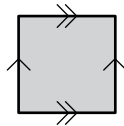

4

Aleki has 24 pencils. He wants to put them into 6 containers. He wants each container to have the same number of pencils. How many pencils will go in each container?
Show how you found the answer.

Did you show your thinking?



Name: _____

Date: _____



Hannah

Using Attributes to Build and Identify Quadrilaterals

- 1 Each critter will get an equal number of beads. Write an equation to represent how many beads each critter will get.



- 2 What is the area of the rectangle?

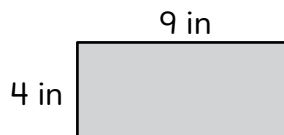

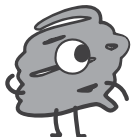
- 3  The shape
- is a quadrilateral.
 - has 1 pair of parallel sides.
 - has no right angles.

Draw the shape.

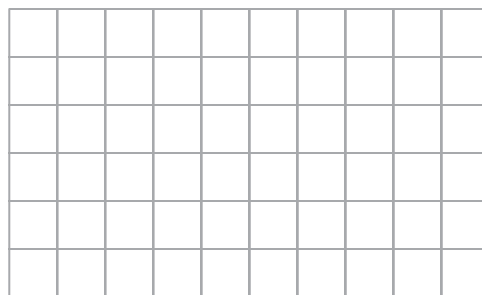

- 4 Arman has 4 packs that have 12 crayons in each pack. Hannah has 6 packs that have 8 crayons in each pack. Do Arman and Hannah have the same number of crayons? Show how you found the answer.

Did you show your thinking?



Name: _____

Date: _____

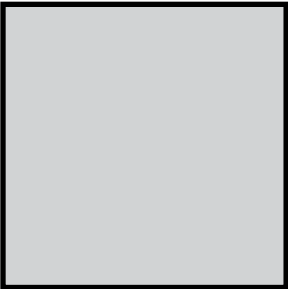

Using String to Measure Perimeter

- 1 Which tool would be the best tool to use to measure the length of a pencil?
- a piece of string a meter stick a ruler
- 2 What is the total value of 2 quarters, 2 dimes, and 2 pennies?
- 3 Write down everything you know about perimeter.
- 4  Which part of the shape shows the perimeter?
- The shaded space inside the line
- The line that goes around the outside of the shape

Did you explain your thinking?



Name: _____

Date: _____



Using Side Lengths to Measure Perimeter

① Continue the pattern. 300, 400, 500, , ,

② Solve and draw a model that shows how you found the answer.

$$18 \div 6 = \boxed{}$$

③ Find the perimeter of the shape. *Show your thinking.* 

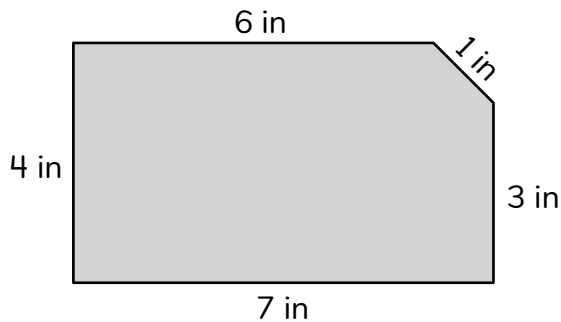

④ Hannah is making a rectangular garden bed for her flowers. The lengths of the longer sides will be 10 feet and the lengths of the shorter sides will be 7 feet. What will the perimeter of the garden bed be? Draw a picture to show how you found the answer.

Did you show your thinking with a drawing?



Name: _____

Date: _____



Strategically Calculating Perimeter

1 Write 2 multiplication and 2 division equations using the numbers 4, 6, and 24.

$\square \times \square = \square$

$\square \div \square = \square$

$\square \times \square = \square$

$\square \div \square = \square$

2 Solve.

$12 + 12 + 15 + 15 = \square$

3 Find the perimeter of the square.



4 m

Show your thinking.

4 Find the perimeter of the rectangle.

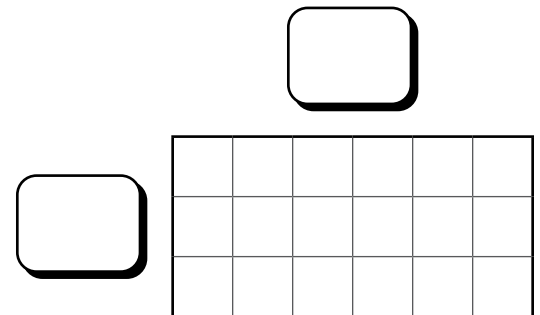

5 Vivi is decorating a birthday cake. She wants to line the perimeter of the top of the cake with blue icing. If the top of the cake is a rectangle that is 9 inches along one side and 13 inches along the other side, how many inches of blue icing will Vivi need? Show how you found the answer.

Did you show your thinking?

Name: _____

Date: _____



Using Perimeter to Find Missing Side Lengths of Polygons

- 1 Draw 2 different shapes that each have 4 vertices.

- 2 Solve.

$$36 \div \square = 6$$

- 3 a) The square has a perimeter of 40 cm.
What are the missing side lengths?

Show
your thinking.



$$P = 40 \text{ cm}$$



- b) How did knowing that the shape is a square help you to solve this problem?

- 4 Vivi has a piece of ribbon that is 24 inches long. She wants to put ribbon around the outside of a birthday card she is making with her *halmeoni*. If the rectangular card has side lengths of 7 inches and 5 inches, does Vivi have enough ribbon? Show your thinking.

Did you show
your thinking?



Name: _____

Date: _____



Arman

Relating Perimeter and Area

1 About how long is a folder?

- 3 centimeters 30 centimeters 300 centimeters

2 Circle all of the quadrilaterals.

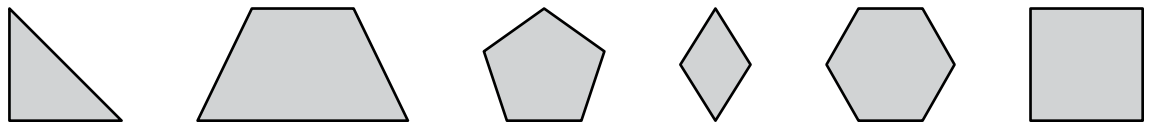

3 a) Find the area and perimeter of the shape.

$$A = \text{square units}$$

$$P = \text{units}$$

b) How did the grid help you find the area and perimeter?

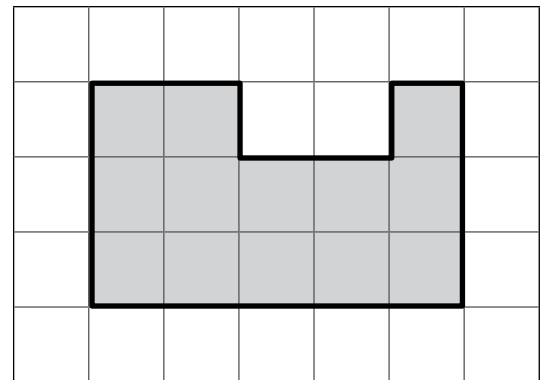

4 Arman is playing a video game in which he is making a rectangle habitat for a snake. He has 24 feet of fencing to make the habitat. He has to make a habitat that gives the snake as much area to move around as possible while keeping a perimeter of exactly 24 feet. What length should he use for each side of the habitat? What area will the habitat have? Draw a picture to show your work.

Did you show your thinking with a drawing?



Name: _____

Date: _____



Exploring a Change in Perimeter or Area of a 2-D Shape

Jaymie

- 1 What time is shown on the clock?

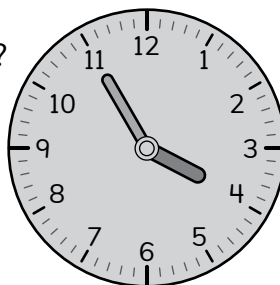

2 Solve. $14 + 14 + 7 + 7 = \square$

- 3 a) Find the area and perimeter of the shape.

$A =$ square units

$P =$ units

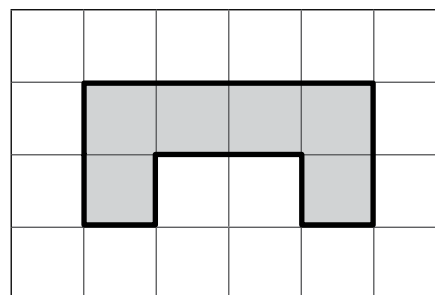

- b) Add one more square unit to the model and find the new perimeter and area.

$A =$ square units

$P =$ units

- 4 Jaymie is running for class president and wants to make a banner for her election. She is looking for a banner with the largest area to write on. She measured the sides of Banner A and Banner B, and she noticed that the banners have the same perimeter but different areas. Which banner should Jaymie choose? Show your thinking.

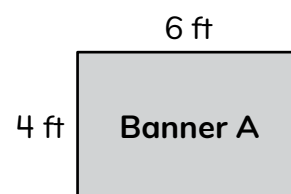
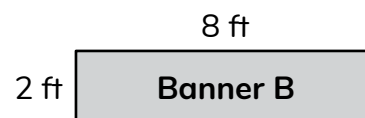

Name: _____

Date: _____



Sarah

Solving Two-Step Problems Involving Perimeter and Area of Rectangles

- 1 Partition the rectangle below into quarters.



- 2 Which of these expressions has a value of 965?

$600 + 90 + 5$

$900 + 60 + 5$

$900 + 600 + 5$

- 3 Sarah is drawing a new garden for tomatoes in her notebook. She needs to find the area of the garden to make sure she buys the correct number of plants. She got some dirt on her notebook, but she knows that the garden is a square that has a perimeter of 28 m. Find the area of the garden.

Show your thinking.



$A =$ square m

- 4 Sarah and her dad used 30 feet of fencing to surround another vegetable garden. What shape might their garden be? What is the length of each side? Show your design below.

Name: _____

Date: _____



Hannah

Using Area to Find Missing Side Lengths of Rectangles

- 1 Solve.

$$48 \div 6 = \square$$

- 2 Partition these rectangles into thirds 2 different ways.



- 3 Use an equation to find the missing information.

- a) If a rectangle has an area of 21 square units and one side length of 7 units, what is the other side length?

- b) If a rectangle has side lengths of 5 units and 6 units, what is the area of the rectangle?

- 4 Hannah's farm has a rectangular field that has a perimeter of 24 yards. If one side length of the field is 8 yards long, what are the other side lengths? Show how you found the answer.

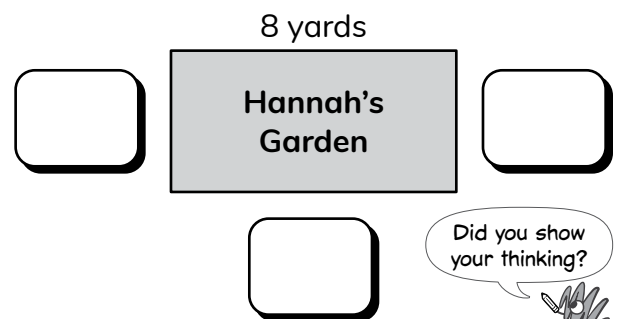

Name: _____

Date: _____



Hannah

Finding the Area of Rectilinear Shapes

- 1 Circle the expression with the greater value. Show your thinking. 

$$4 \times 8$$

$$3 \times 9$$

- 2 Find the product of 3×4 . Is the product odd or even?

- 3 Draw and color a shape on the grid that matches the value of these expressions.

$$8 \times 2 \text{ add } 2 \times 2$$

square units

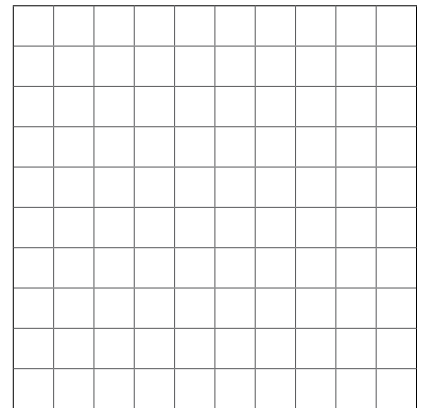

- 4 Hannah is planting a lettuce garden. She already planted 7 columns of lettuce with 3 seeds in each column. She has 4 extra spots on the side where she can grow additional lettuce plants. How many lettuce plants can she grow in her garden?

Hannah's Lettuce Garden

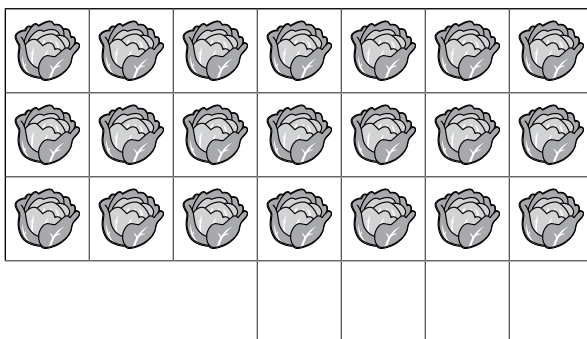

Name: _____

Date: _____



Using a Grid to Find the Area of Rectilinear Shapes

- ① Use $>$ or $<$ to make the inequality true.

$$6 \times 6 \bigcirc 4 \times 8$$

- ② Solve.

$$376 + 200 = \boxed{}$$

- ③

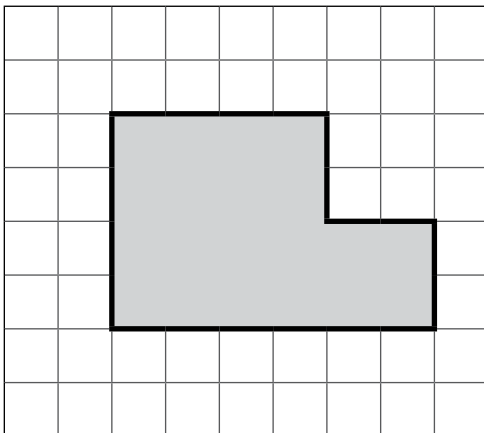

What is the total area of the shape?
Label the side lengths you used.

Show
your thinking.



- ④

Sarah and her dad want to make sure they have enough space for some of the things they want to plant in the community garden. If their rectangular rose garden has side lengths of 5 feet and 3 feet and their vegetable garden has side lengths of 6 feet and 4 feet, what is the total area of both gardens? Draw a picture to show how you found the answer.

Did you show your thinking
with a drawing?



Name: _____

Date: _____



Using Side Lengths to Find the Area of Rectilinear Shapes

① Solve. $275 + 89 = \square$

② Use the number line to show how to find the product of 4×5 .

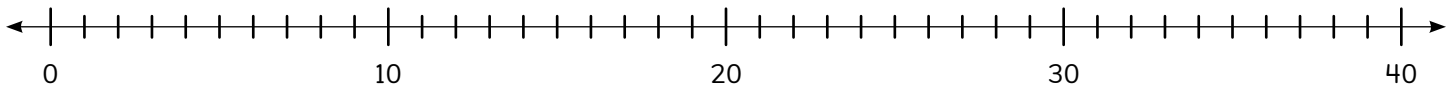

③ Sarah's dad has another option for the shape of a new garden. What is the area of this vegetable bed?

Show your thinking.

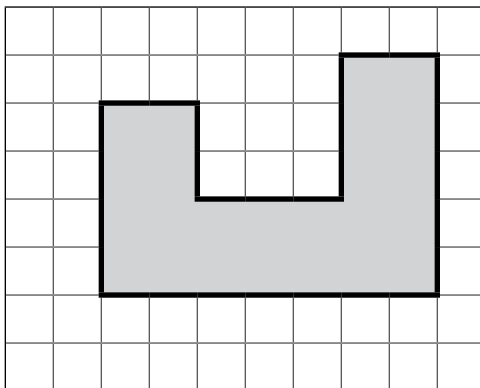

 1 ft
1 ft

④ Sarah is planning a new garden bed for the community garden. She has 32 feet of fencing to enclose the garden bed. Sarah has measured 7 of the bed's side lengths: 8 feet, 8 feet, 3 feet, 2 feet, 3 feet, 2 feet, and 4 feet. What is the remaining side length of the garden bed? Use the grid to draw a picture of the bed.

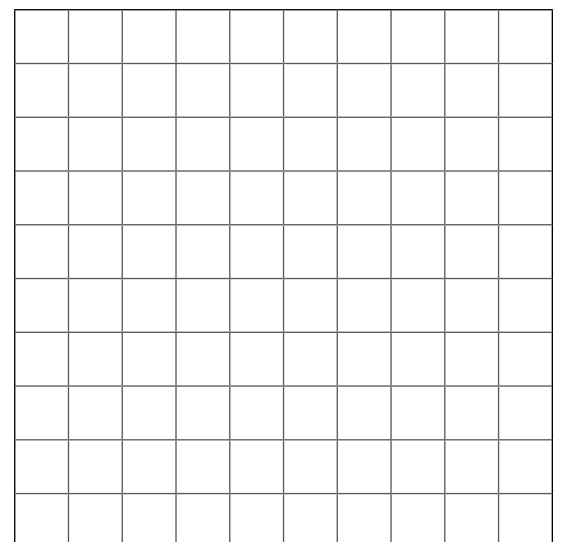

Name: _____

Date: _____



Aleki

Arman

Solving Word Problems Involving the Area of Rectilinear Shapes

- 1 Circle all of the rectangles that are partitioned into fourths.

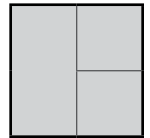
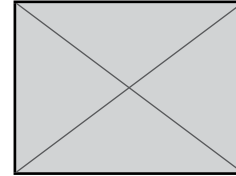
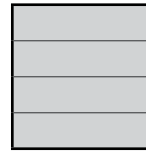
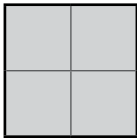

- 2 Solve.

$$14 + 14 + 8 + 8 = \boxed{}$$

- 3 Aleki wants to paint a wall in his basement next. The wall has a window in it. Aleki has enough paint for 30 square meters. Does he have enough paint to cover the basement wall?



Show your work.

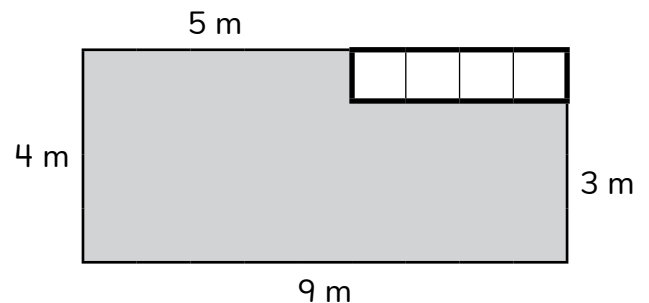

- 4 Arman builds a mosaic that has an area of 36 square inches. There is a blue rectangle in the center of the mosaic with side lengths of 3 inches and 4 inches. The remainder of the mosaic has only red tiles. What is the area of the red section of the mosaic? Show your thinking.

Did you show your thinking?



Topic 5

Extending Multiplication and Division Strategies

Recommended ST Math Objectives:

Multiplication and Division Facts

Multiplication as Comparison

Solve Two-Step Problems

Name: _____

Date: _____



Partitioning Rectangles to Calculate Products

- ① Solve.

$$56 \div \square = 8 \quad 63 \div 9 = \square$$

- ② Solve.

$$370 + 30 = \square$$

- ③ Circle ALL the expressions that could be used to find the product shown in the model.

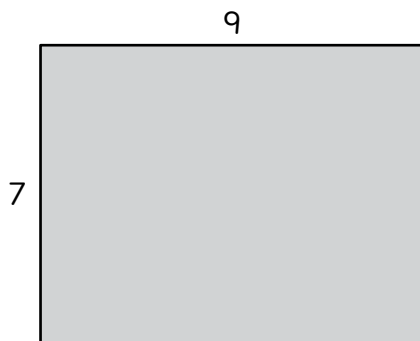

$$7 \times 9$$

$$(7 + 4) \text{ added to } (7 + 5)$$

$$(7 \times 4) \text{ added to } (7 \times 5)$$

$$(7 \times 2) \text{ added to } (7 \times 7)$$

- ④ Aleki is painting a mural on his wall. He wants to cover a rectangular space that has side lengths of 8 feet and 4 feet. What is the area of the mural that Aleki will paint? Write an equation to show how Aleki could find the area.

Did you show your thinking with an equation?



Name: _____

Date: _____



Sarah

Introducing Parentheses as Grouping Symbols

1 If $4 \times 9 = 36$, what is the value of $36 \div 9$?

2  How is this rectangle partitioned?

halves

thirds

fourths

3 a) Here are 2 equations to find the area of the shape.
Circle the equation that makes it easier to find the area.

$$(6 \times 7) + (6 \times 2) = \square$$

$$(6 \times 5) + (6 \times 4) = \square$$

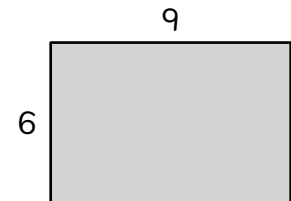

b) Why did you choose that equation?

4 Sarah's garden has 3 rows of squash and 5 rows of corn. There are 6 plants in each row. How many plants are in Sarah's garden?

Name: _____

Date: _____



Generating Multistep Expressions With and Without Parentheses

- 1 What is a reasonable estimate for the number of days in the third grade school year?
- 20 days 200 days 2,000 days
- 2 Vivi has 8 pages of stickers in her sticker book. If each page has 9 stickers, how many total stickers does Vivi have in her sticker book? Write an equation and solve. 
- 3 Find the value of each expression. Circle the expression that has the greatest value.
- a) $2 \times (5 + 3)$ $(2 \times 5) + 3$
- b) $36 \div (9 - 3)$ $(36 \div 9) - 3$
- 4 Jaymie has 6 boxes of markers to share with the class. Each box contains 8 markers. She also has 14 markers from the art table. How many markers does Jaymie have?

Name: _____

Date: _____



Jaymie

Using Divisibility Rules to Identify Evens and Odds

- ① Find the perimeter of the figure.

$$P = \boxed{} \text{ cm}$$

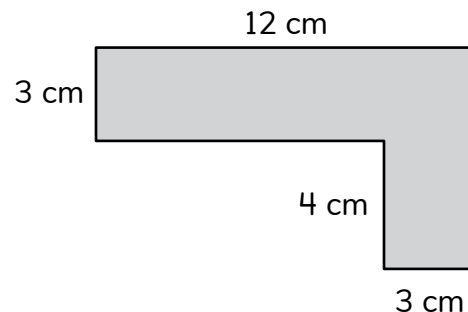

- ② Circle the words that describe all the figures in the group.

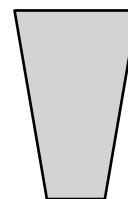
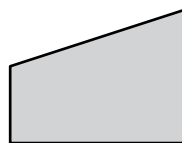

parallelograms

quadrilaterals

trapezoids

- ③ Circle the numbers that are divisible by 2.

7

634

50

83

28

106

241

- ④ a) Write a 2-digit odd number.

- b) Write a 3-digit odd number.

- ⑤ Jaymie's class collected 135 notebooks and 247 folders. They donated 150 items to a local charity. How many items did they keep? Show how you found the answer.

Did you show your thinking?



Name: _____

Date: _____



Naomi



Vivi



Jaymie

Exploring the Associative Property of Multiplication

- 1 Naomi buys a candy bar for 83¢. List the fewest possible coins Naomi could use to buy the candy bar.

- 2 Partition these rectangles into halves 2 different ways.

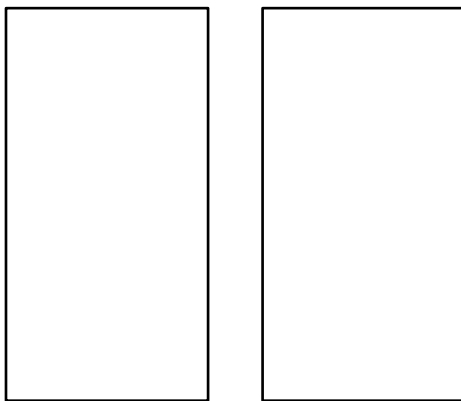

- 3 a) Solve.

$$3 \times (2 \times 5) = \square$$

$$(3 \times 2) \times 5 = \square$$

- b) Which equation has the greatest total? Why?

- 4 Vivi has 3 bead organizers. Each bead organizer has 2 sections containing 4 beads. Jaymie has 2 bead organizers. Each bead organizer has 4 sections containing 3 beads. Compared to Vivi, does Jaymie have more beads, fewer beads, or the same number of beads? Use these models to help you draw and solve.

Vivi's Bead Organizers

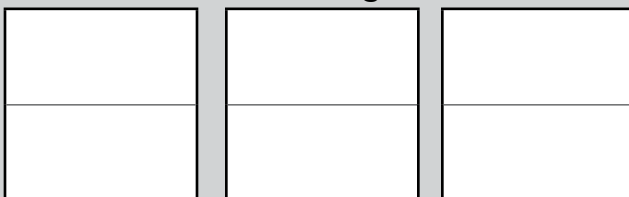

Jaymie's Bead Organizers

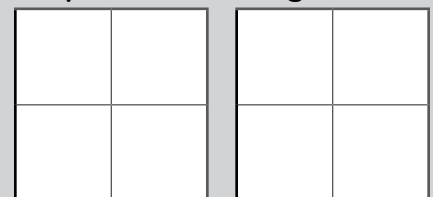

Name: _____

Date: _____



Dani

Using the Associative Property to Multiply One-Digit Numbers by Multiples of 10

1

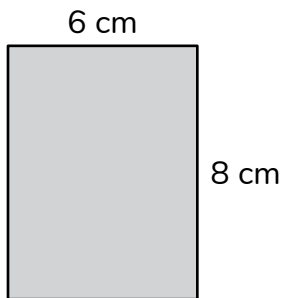

Find the area of the rectangle.

2

Continue the pattern.

110, 115, 120,



3

a) Write an equation to represent the model.

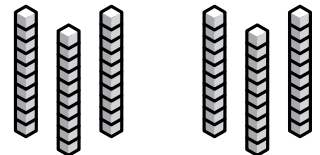

b) Solve the equation for this model and explain how you solved.

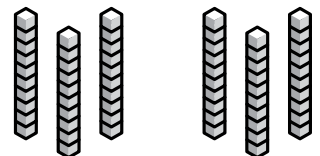
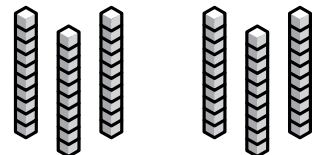

4

Dani buys packs of beads for a new design she is making. Beads come in packages of 10. She buys 3 packs of yellow beads, 2 packs of purple beads, and 2 packs of green beads. What is the total number of beads that Dani has for her design? Draw a model to show your thinking.

Did you show your thinking with a model?



Name: _____

Date: _____



Dani

Using the Associative Property of Multiplication Strategically

- ① Solve.

$$30 \div 6 = \square$$

$$9 \times 8 = \square$$

$$48 \div 8 = \square$$

- ② Find the perimeter of the rectangle.

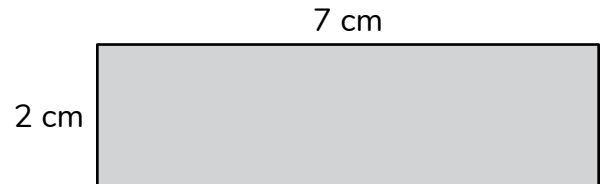

- ③ I am thinking of an equation. The product is 240.

a) My equation could be $\square \times \square = 240$.

b) What other factors could make this equation true?

$$\square \times \square = 240$$

- ④ Dani buys a box that contains 120 beads. There are bags inside the box that each contain 40 beads. How many bags of beads are in the box? Show how you found the answer.

Did you show your thinking?



Name: _____

Date: _____



Writing Equations to Solve Multiplication and Division Problems

- 1 a) Solve.

$$23 + 16 + 7 = \square$$

- b) Explain the strategy you used to solve the problem.

- 2 a) Mateo took 18 pencils and put the same number of pencils into the 3 cups. How many pencils were in each cup?

- b) Mateo cleaned up his art room and put the pencils and the paintbrushes together. How many did he have altogether? Show your work.

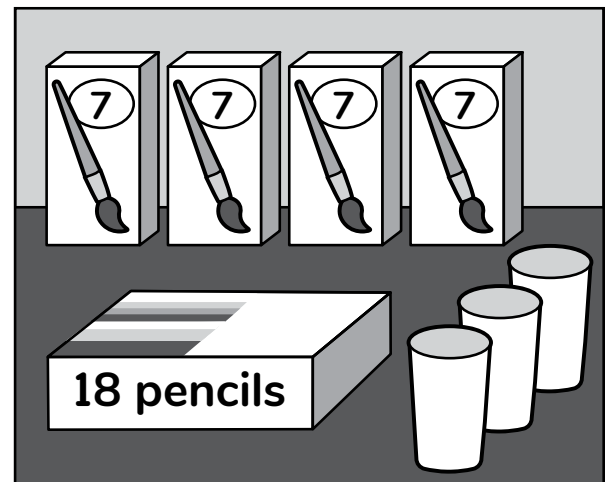

Show your thinking.

- 3 Jaymie is organizing Mateo's supplies for Art Club. She picks up 6 bins of glue sticks. Each bin contains 9 glue sticks. How many glue sticks are there? Show your work.

Did you show your thinking?

Name: _____

Date: _____



Sarah

Representing Two-Step Multiplication and Division with Array Models

- ① Complete the equation.

$$90 = \square \times 9$$

- ② Use the number line to complete the equation.

$$4 \times \square = 28$$



- ③ a) Create your own expression by circling an operation symbol.

- b) Draw an array to represent your expression.

$$3 \times 4 \begin{array}{|c} \times \\ \div \\ + \end{array} 2$$

- ④ Sarah picked 48 tomatoes from her garden. She wants to pack the tomatoes equally into 6 baskets. How many tomatoes will go in each basket? Write an equation to represent the problem.

Did you write an equation?



Name: _____

Date: _____



Hannah

Exploring the Inverse Relationship Between Multiplication and Division

- 1 Choose the most appropriate tool to measure the length of your pencil.

ruler

meterstick

The creatures are here! Each creature represents a number based on the number of legs it has. Circle the creature or number that makes the equations true.

- a) 4  share their shoes with 5

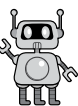

$$\square \times \square \div \square = \square$$

- b) 2  share their shoes with 3

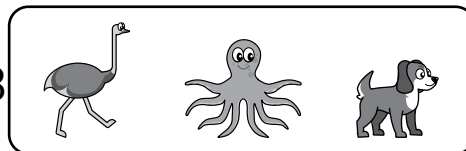

$$\square \times \square \div \square = \square$$

- 3 Hannah is planting vegetables in her garden. She has 4 rows of 6 pumpkins. When she harvests the pumpkins, she puts them into 3 crates. If each crate has the same number of pumpkins, how many pumpkins are in each crate? Use the model to show how you found the answer.

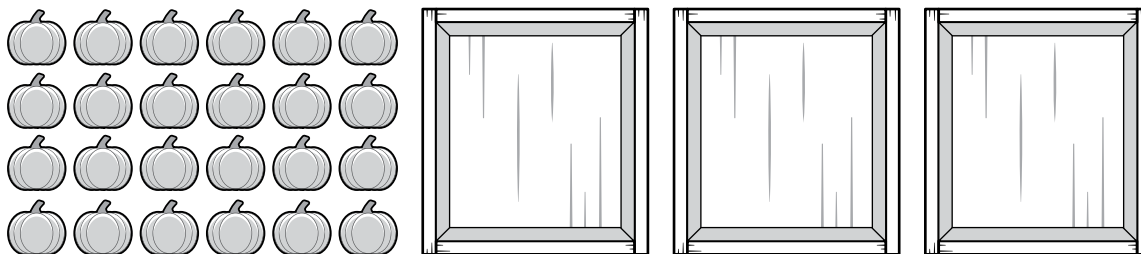

Name: _____

Date: _____



Hannah

Representing Two-Step Multiplication and Division with Strip Diagrams

- 1 Write an equation to represent the strip diagram.

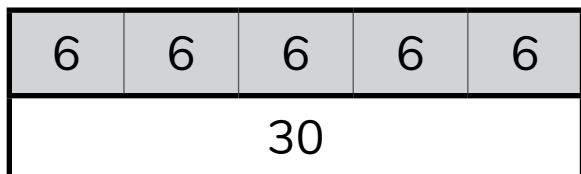

- 2 What is the missing side length?

$$P = 45 \text{ inches}$$

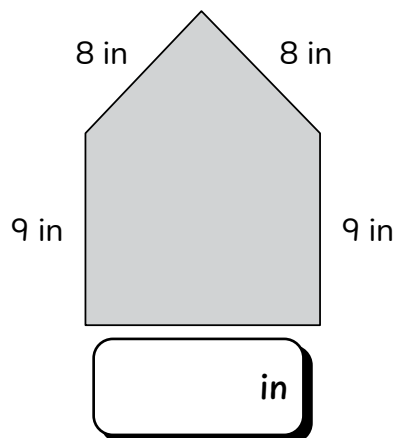

- 3  I have 36 blocks and sorted them equally into 4 buckets. Each bucket is shared equally by 3 critters.

How many blocks does each critter get?

Create a strip diagram and write an equation to represent the problem.

- 4 At the farmers market, Hannah sold 6 containers with 5 tomatoes in each container. She also sold 4 additional tomatoes. How many tomatoes did she sell? Solve with an equation.

Did you solve with an equation?



Name: _____

Date: _____



Mateo

Representing Two-Step Problems with Single Equations

- 1 Circle the shape with the greater area.

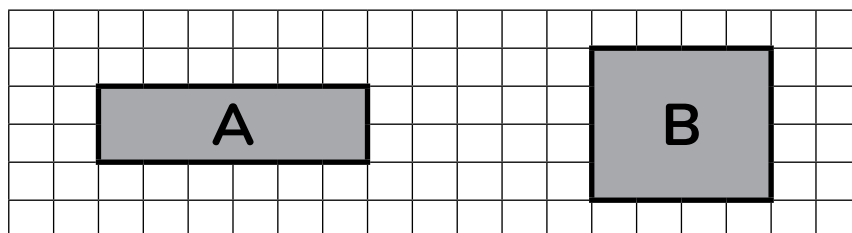

Area of Rectangle A = square units

Area of Rectangle B = square units

2 $36 \div 4 = \square$

\times =

Use multiplication
to find the quotient!



3

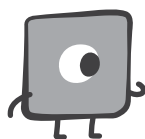

I put 72 craft sticks in cups,
placing 8 craft sticks in each cup.
4 craft sticks in each cup are blue.

How many craft
sticks are blue?

Write a single equation to represent how you solved the problem.

4

Mateo has 7 purple markers and 3 green markers in a cup. 4 of the markers do not work. How many markers work? Show how you know.

Did you show
your thinking?



Name: _____

Date: _____

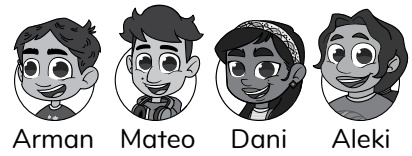

Using Multiplication and Division to Complete the Key on Pictographs

1 Arman has 3 pieces of rope to practice his knots. The first piece is 24 inches. The second piece is 32 inches. The third piece is 18 inches. What is total length in inches of Arman's rope?

2 Look at the number line below. Draw an X where 45 would go.

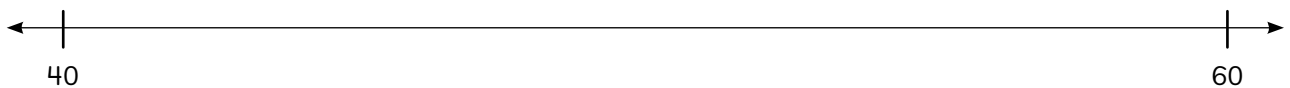

3 Using the graph, answer the following questions from the lesson.

- a) How many fish were caught?
- b) Who caught the fewest fish?
How many did they catch?

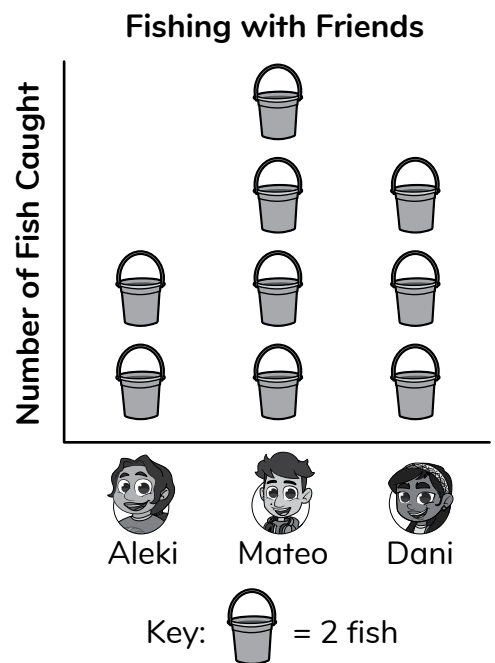

4 Mateo and Dani each had 5 worms for fishing. Aleki had 8 worms. How many worms in total did they have for fishing? Show how you found the answer.



Name: _____

Date: _____



Dani

Modeling and Solving Open-Ended Multiplication and Division Problems

- 1 Partition the circle into fourths.
Shade the circle to show 4 fourths.

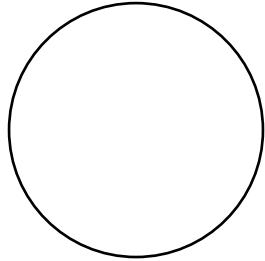

- 2 Solve.

$$450 + 160 = \boxed{}$$

- 3 Dani and her brother did not have enough room to put away all of their books. Dani got 54 feet of wood to make more shelves. If she uses all of the wood, how many of each shelf length can she make?

Show how you solved this problem.



5 foot shelves:

8 foot shelves:

9 foot shelves:

10 foot shelves:

- 4 Dani has 6 shelves that each contain 7 books. She needs to build another shelf for the 5 books sitting on the table. How many books does Dani have? Show how you found the answer.

Did you show your thinking?



Name: _____

Date: _____



Using Place Value Strategies to Find the Area of Rectangles

- ① The hexagon has a perimeter of 60 units. What are the hexagon's side lengths?

$$P = 60 \text{ units}$$

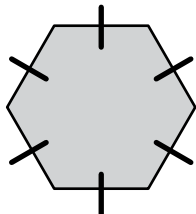

units

- ② Solve. $\times 8 = 40$

- ③ What is the area of a rectangle with the side lengths of 53 cm and 4 cm?

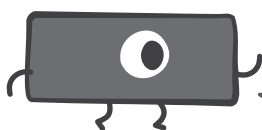

Use your base ten blocks or draw an open area model!

square centimeters

- ④ Mateo painted 6 paintings of flowers. Each painting had 3 sunflowers. Which equation can be used to find the total number of sunflowers Mateo painted?

$$6 \div 3 = 2$$

$$6 \times 3 = 18$$

$$6 + 3 = 9$$

$$6 - 3 = 3$$

Name: _____

Date: _____



Aleki

Using Area Models to Multiply One-Digit by Two-Digit Numbers

- 1 Circle the critter that is correct.

$$4 \times 8$$

This means
8 more than 4.

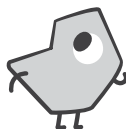

This means 8 split
into 4 equal groups.

This means 4 times
as much as 8.



- 2 What is the total area of the figure?

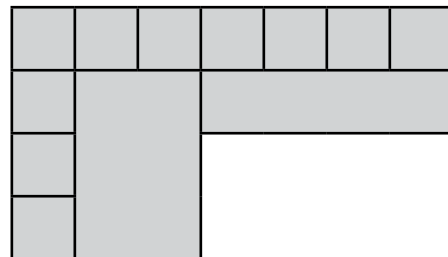

- 3 Complete the equations to find the product of 7×54 .

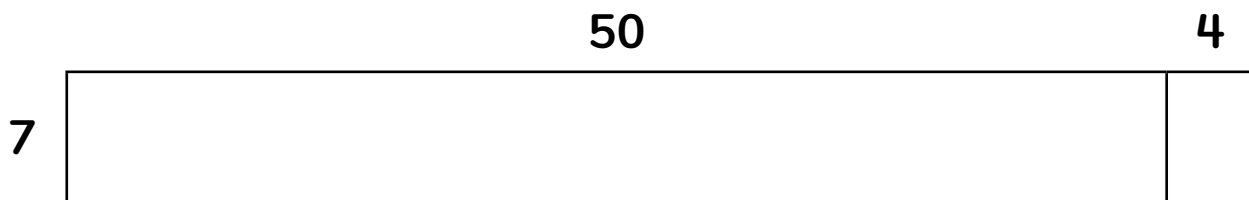

$$\begin{aligned} 7 \times 54 &= (7 \times \boxed{}) + (7 \times \boxed{}) \\ &= \boxed{} + \boxed{} \\ &= \boxed{} \end{aligned}$$

- 4 Aleki has 9 albums. Each album has 12 songs.
What is the total number of songs on all the albums?

Name: _____

Date: _____



Jaymie

Connecting Area Models to the Standard Algorithm

1 Circle the statement that is true about all the shapes.

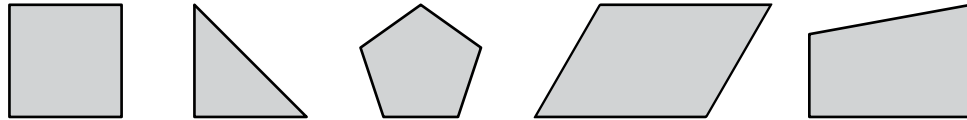

All the shapes are parallelograms.

All the shapes are quadrilaterals.

All the shapes are polygons.

2 This is 1 row of an array. How many squares are in 9 rows?

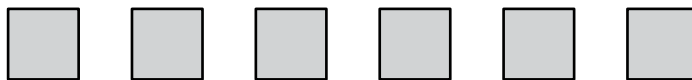

squares

3 Solve using partial products and an area model.

$$\begin{array}{r} 84 \\ \times 7 \\ \hline \end{array}$$

←

$$\begin{array}{r} \\ + \\ \hline \end{array}$$

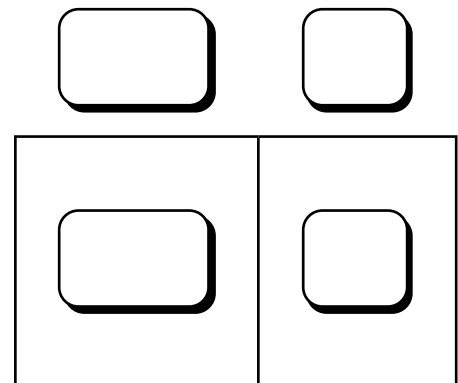

4 The square rug in Jaymie's classroom has a perimeter of 20 square feet. What are the side lengths of the rug? Show how you know.

Did you show your thinking?



Name: _____

Date: _____



Sarah

Applying the Standard Algorithm to Multiply Two-Digit Numbers

- ① Complete the equation to make it true.

$$6 \times 4 = 8 \times \square$$

- ② a) What is the area of the rectangle?

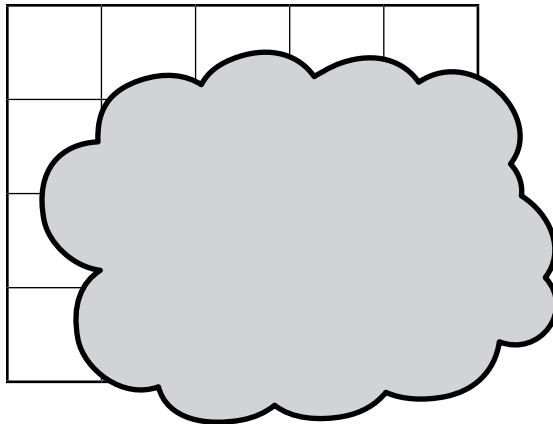

square units

- b) Write an equation to show how you found the area of the rectangle.

- ③ Solve using the standard algorithm.

$$\begin{array}{r} \square \\ 45 \\ \times \quad 8 \\ \hline \square \square \end{array}$$

$$\begin{array}{r} \square \\ 27 \\ \times \quad 3 \\ \hline \square \square \end{array}$$

- ④ Sarah's garden has 4 rows of strawberry plants, with 8 plants in each row. She has twice as many tomato plants as strawberry plants. Write an equation to find the total number of tomato plants in the garden.

Did you write an equation?



Name: _____

Date: _____



Solving Open-Ended Problems with the Standard Algorithm

1 Solve. $\square = 7 \times 8$

2 Draw the shape the critter is thinking about.

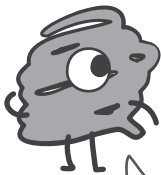

The shape

- is a quadrilateral.
- has at least 1 set of parallel sides.
- has at least 2 sides that are congruent.

3 a) Solve using partial products.

$$\begin{array}{r} 42 \\ \times 6 \\ \hline \end{array}$$

b) Solve using the standard algorithm.

$$\begin{array}{r} 42 \\ \times 6 \\ \hline \end{array}$$

c) How are the 2 strategies similar? How are they different?

4 Dani made a rectangular wooden bookmark that has side lengths of 5 inches and 1 inch. What is the perimeter of the bookmark?

Name: _____

Date: _____



Mateo

Modeling and Solving Multiplication and Division Problems Efficiently

① Make the comparison true. $614 < \square$

② What is the perimeter of the trapezoid?

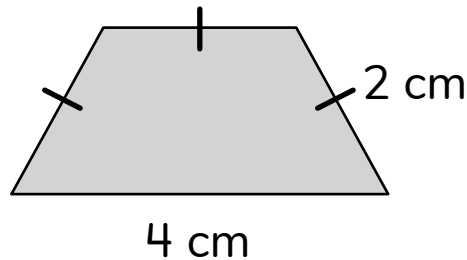

$P = \square$

③ What is another way the critter could have solved this equation?

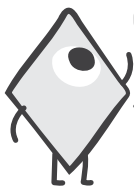
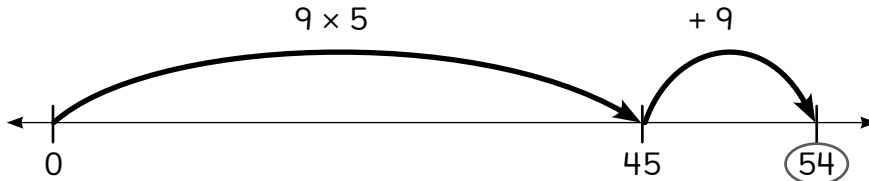

This is how I solved
 $9 \times 5 + 9 = \square!$

④ Mateo bought containers to organize 108 art supplies. Each container fits 9 art supplies. How many containers did Mateo buy? Show how you know.



Mateo bought \square containers for his art supplies.

Topic 6

Extending Place Value and Adding and Subtracting Efficiently

Recommended ST Math Objectives:

Place Value to 100,000

Addition and Subtraction within 1000 Strategies

Composing and Decomposing within 1000

Name: _____

Date: _____



Aleki

Representing Numbers to 100,000 with Base Ten Block Relationships

1 Is 21 divisible by 2? Explain your thinking.

2 Solve.

$$\begin{array}{r} 38 \\ \times 4 \\ \hline \end{array}$$

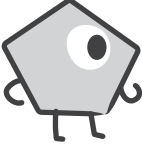
3  What number is represented by the base 10 blocks?

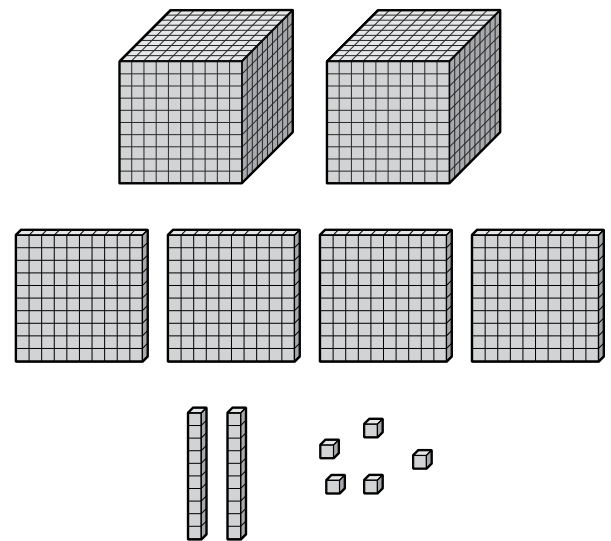
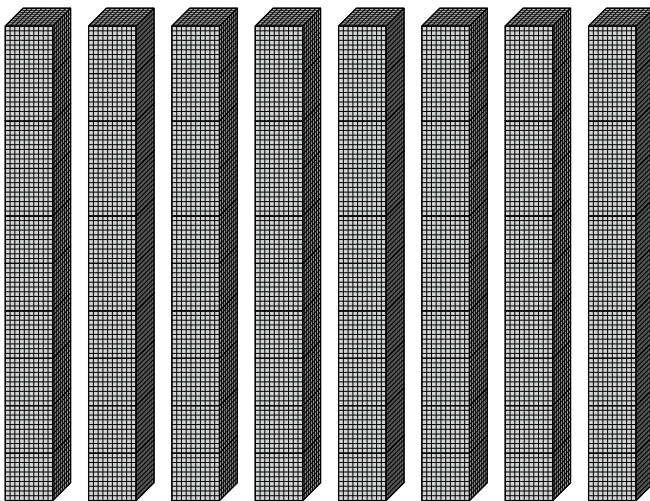

4 Aleki has a bookcase with 8 shelves. There is space for 7 albums on each shelf. How many albums can fit in the bookcase? Show how you know.

Did you show your thinking? 

Name: _____

Date: _____



Dani

Using Place Value to Name and Write Numbers to 100,000

1

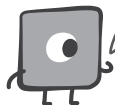

Write these
2 equations as
a single equation.

$$48 \div 4 = 12$$

$$12 \div 6 = 2$$

2

Complete the expression to calculate the area.

$$(\square \times \square) + \square$$

$A =$

square units

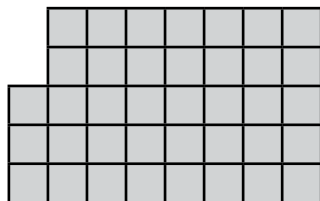

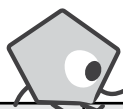

3

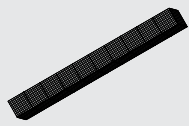
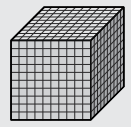
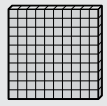

My number has 4 thousands,
3 ones, 7 hundreds, 6 tens,
and 8 ten thousands.

Use numerals to
represent my number on
the place value chart.

 Hundred Thousands	 Ten Thousands	 Thousands ,	 Hundreds	 Tens	 Ones
		,			

4

Dani bought 5 packs of small metal brackets and 2 packs of large metal brackets for a building project. Each pack had 12 brackets. How many brackets did she buy in total? Show how you know.

Did you show
your thinking?



Name: _____

Date: _____



Using Expanded Notation to Name and Write Numbers to 100,000

① Find the product. $34 \times 6 = \boxed{}$

② Write a multiplication equation to represent the model.

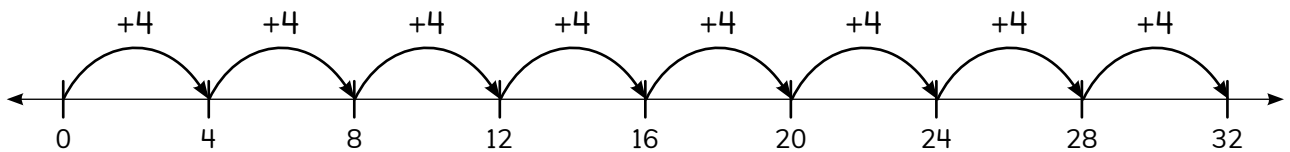

③ Write the number in expanded form and in expanded notation.

34,816

Expanded Form

Expanded Notation

④ Vivi has 63 stickers to fill 7 pages in her album. She puts the same number of stickers on each page. How many stickers does she put on each page? Explain your thinking.

Did you explain your thinking?



Name: _____

Date: _____



Mateo

Representing Multiplication Relationships Between Place Values

- ① Solve using a strategy or model of your choice.

$$4 \times 5 \div 2 = \boxed{}$$

- ② Complete the equation to find the product of 8×14 .

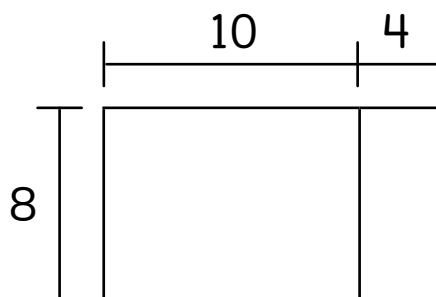



$$8 \times 14 = (\boxed{} \times \boxed{}) + (\boxed{} \times \boxed{})$$

$$= \boxed{} + \boxed{}$$

$$= \boxed{}$$

- ③ Use the place value chart to solve.

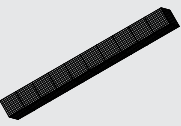
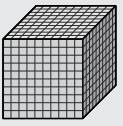
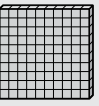
$$70 \times \boxed{} = 7,000$$

 Hundred Thousands	 Ten Thousands	 Thousands ,	 Hundreds	 Tens	 Ones
				7	0

Name: _____

Date: _____



Arman

Using the Number Line to Find Nearby Numbers Within 100,000

- 1 Complete the model and solve.

$$18 \div 2 \div 3 = \boxed{}$$

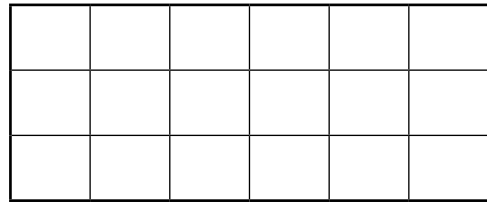

- 2 Which shapes are parallelgrams?

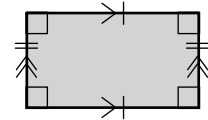
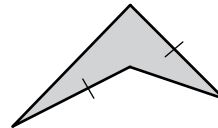
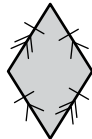
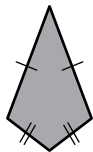
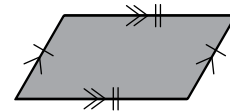
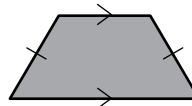
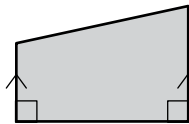
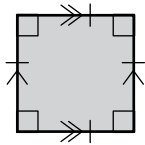

- 3 a) Place 4,281 on the number line and label each tick mark.

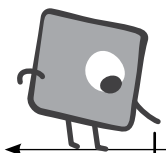

The tick marks here represent thousands..

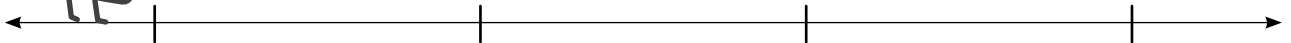

- b) Which thousand is nearest 4,281?

- 4 Arman has 36 planet cards and 28 star cards that he wants to sort into a binder. If each binder page holds 8 cards, how many pages will he need? Show how you know.

Did you show your thinking?



Name: _____

Date: _____



Comparing Numbers Within 100,000

1

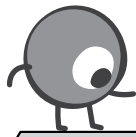

My bookcase has 4 shelves.

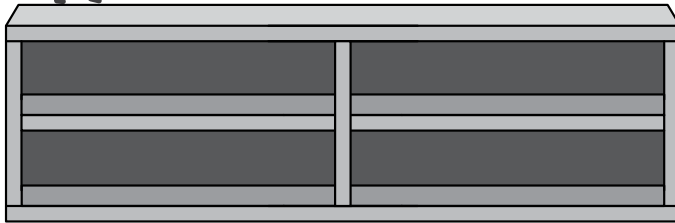

How many shelves would 6 of these bookcases have?

shelves

2

Circle the equation that could be used to find the quotient. Then solve the equation.

$$42 \div 6 = \square$$

$$42 + 6 = 48$$

$$42 \times 6 = 252$$

$$7 \times 6 = 42$$

$$6 + 36 = 42$$

3

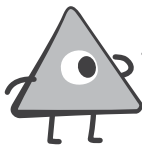

Which sign will make this comparison true?

$$2,035 \bigcirc 2,305$$

3

Mateo had 3 boxes of pencils. There were 12 pencils in each box. He placed 9 cups on the art table and put an equal number of his pencils into each cup. How many pencils did he put in each cup? Show how you know.

Did you show your thinking?



Name: _____

Date: _____



Rounding to the Nearest 10

① $781 - 200 = \square$

- ② Mateo has a piece of ribbon that is 42 inches long. He cuts off 19 inches to use on a birthday present. How much ribbon does Mateo have left?

Did you show your work?



- ③ a) Write 3 numbers that would round to 70 when rounded to the nearest ten.

b) Write 3 numbers that would round to 80 when rounded to the nearest ten.

- ④ Sarah has 143 seeds for her garden. To know about how many seeds to order for next year, she wants to round this number of seeds to the nearest ten. What number should she round to? Explain your reasoning.

Did you explain your reasoning?



Name: _____

Date: _____



Rounding to the Nearest 100

- ① Fill in the missing numbers on the number line below.

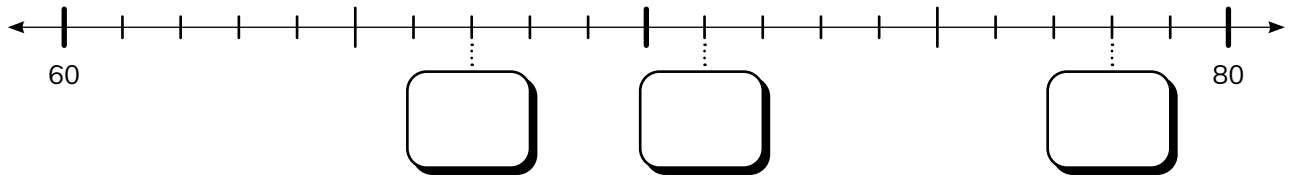

- ② Round 36 to the nearest 10.

- ③ Sarah says that 364 rounds to both 360 and 400. Do you agree with Sarah? Prove your thinking.

- ④ a) Round 655 to the nearest 10. b) Round 655 to the nearest 100.

- ⑤ Jaymie has about 50 sheets of blue and green paper. If 37 sheets of paper are blue, about how many sheets of green paper does Jaymie have? Explain your reasoning.

Did you explain your reasoning?



Name: _____

Date: _____

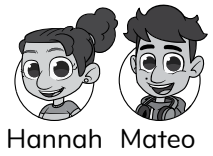

Using Rounding to Estimate the Total

- 1 Circle the squares that are partitioned into quarters.

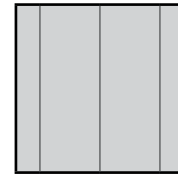
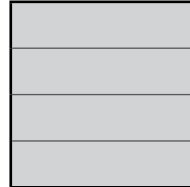
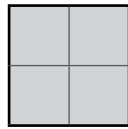
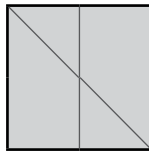

- 2 Round 392 to the nearest 10.

- 3 Hannah bought a hat and glove to start the new baseball season. About how much money did she need to buy the hat and glove?



Show your thinking.



- 4 The total cost of Hannah's sports equipment is \$188. What is \$188 rounded to the nearest 10? What is \$188 rounded to the nearest 100?

- 5 Mateo ordered new supplies for his art studio. He ordered 56 colored pencils. If there were 8 colored pencils in each box, how many boxes of colored pencils did Mateo order? Show how you found your answer.

Name: _____

Date: _____



Hannah

Using Sequential Strategies to Add and Subtract Three-Digit Numbers

1 Draw a picture to represent 4×7 .

2 Solve this riddle.

- I am a 2-digit number.
- I am less than 80 but greater than 70.
- I am an even number.
- I round to 80 when rounded to the nearest ten.
- The sum of my digits is 15.

What number am I?

3 Solve.

$$634 + 144 = \boxed{}$$

$$548 - 253 = \boxed{}$$

4 Hannah tracks her steps along the garden path. Her step tracker showed 285 steps before she entered the garden. When she got to the end of the garden path, the tracker showed 523 steps. How many steps did Hannah take on the garden path? Show how you found your answer.

Did you show your thinking?



Name: _____

Date: _____



Using Decomposition Strategies to Add and Subtract Three-Digit Numbers

- 1 a) Round 895 to the nearest 10. b) Round 112 to the nearest 100.
- 2 a) Use the strategy of your choice to find the sum of $528 + 274$.
- b) Use a different strategy to find the sum of $342 + 449$.
- 3 Mateo had an art show to share the art his friends created. On Thursday, 156 people visited the show. On Friday, there were 243 visitors. On Saturday morning, another 75 visitors came to the art show. Over these 3 days, how many visitors came to Mateo's art show? Show how you found your answer.

Did you show your thinking?



Name: _____

Date: _____



Using Partial Sums to Add Three-Digit Numbers

- 1 Find the perimeter and area of the square below.



- 2 Finish this sentence:

$$\text{If } 7 \times 6 = 42, \text{ then } 42 \div 7 = \square$$

- 3 Find the sum of $632 + 268$ using 2 different strategies.
Circle the strategy that works the best for you.

- 4 Aleki's class is figuring out how many tickets the school will need to buy for the upcoming field trip to the theater. If there are 342 students in Kindergarten, 1st grade, and 2nd grade and 279 students in 3rd grade, 4th grade, and 5th grade, how many tickets will need to be purchased for all students to attend? Show your thinking.

Did you show your thinking?



Name: _____

Date: _____



Solving Word Problems Involving Addition and Subtraction of Three-Digit Numbers

- ① The school auditorium has 500 seats. Only 23 seats are empty. How many seats are filled? Use the number line to solve the problem.



② $400 - 12 = \boxed{}$

- ③ Sarah's class planted 135 carrot seeds and 229 pumpkin seeds in their school garden. Draw a strip diagram to help you find how many seeds Sarah's class planted in all.

- ④ Vivi has some new stickers. If she has 7 pages of stickers and there are 6 stickers on each page, how many new stickers does Vivi have? Write an equation and solve.

Did you show your thinking with an equation?



Name: _____

Date: _____



Hannah

Using Estimation to Solve Three-Digit Addition and Subtraction Problems

① $72 \div 8 = \boxed{}$

② Solve this riddle:

- I am a 3-digit number.
- I am less than 400 but greater than 200.
- I am an even number.
- I round to 350 when rounded to the nearest 10.
- The sum of my digits is 13.

What number am I?

③ Is this equation true or false?  Show your thinking.

$$387 + 165 = 876 - 324$$

④ Hannah and her dad were at the farmers market on a busy Saturday morning. Before it rained, there were 410 visitors. After it rained, there were 185 people remaining. How many visitors left during the rain? Draw a strip diagram and write an equation to show your thinking.

Did you show your thinking?



Name: _____

Date: _____



**Solving Two-Step Word Problems Involving
Addition and Subtraction of Three-Digit Numbers**

- 1 Find the sum of $281 + 519$.

Did you show your work?

- 2 Find the sum of $281 + 519$ using a different strategy. Show your strategy.

- 3 Donner and his aunt take the Lake Trail from the trailhead to the campsite. How far do they hike? Model the problem with a strip diagram.

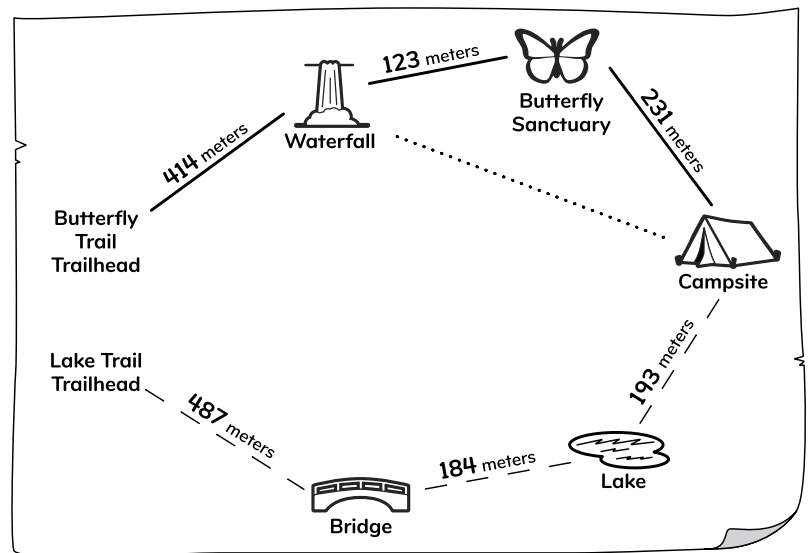

- 4 Naomi is organizing her shell collection. She has 36 shells and wants to put 9 shells in each container. How many containers will Naomi need to organize the shells? Write an equation to represent this problem and solve.

Did you show your thinking with an equation?

Name: _____

Date: _____



**Using Estimation to Solve Two-Step Word Problems
Involving Three-Digit Addition and Subtraction**

- ① Use the numbers 7, 9, and 63 to write 2 multiplication equations and 2 division equations.

$$\square \times \square = \square$$

$$\square \div \square = \square$$

$$\square \times \square = \square$$

$$\square \div \square = \square$$

- ② Round 349 to the nearest hundred.

- ③ On a road trip, Donner's family drove 187 miles on Saturday morning and 115 miles on Saturday afternoon. On Sunday, they drove 387 miles. How many more miles did they drive on Sunday than on Saturday? Use the number line to model and help you solve.



- ④ Vivi got a new book to hold her stamp collection. If the book has 8 pages and each page can hold 6 stamps, how many stamps can this book hold? Write an equation to represent the problem and solve.

Did you show your thinking with an equation?



Name: _____

Date: _____



Donner

Choosing Strategies to Flexibly Add and Subtract Three-Digit Numbers

- 1 What time is shown on the clock?

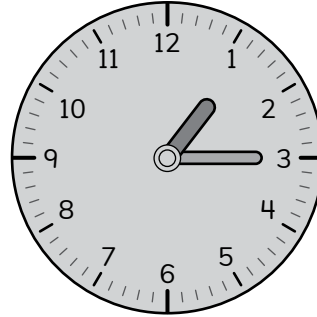

- 2 What is the missing factor?

$$6 \times \boxed{} = 54$$

- 3 Model and solve.

$$387 + 464 = \boxed{}$$

$$746 - 125 = \boxed{}$$

- 4 Donner hiked 953 meters on Saturday. He hiked 267 fewer meters on Sunday. How many meters did Donner hike on Sunday?

Show how you know.



Donner hiked on Sunday.

Topic 7

Discovering Fractions

Recommended ST Math Objectives:

Fraction Concepts
Fractions on the Number Line
Number Patterns

Name: _____

Date: _____



Partitioning Area Models into Equal Parts

- 1 Find the area of this square.

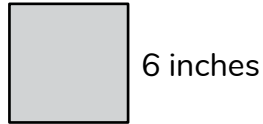

- 2 Partition the squares into quarters in 2 different ways.

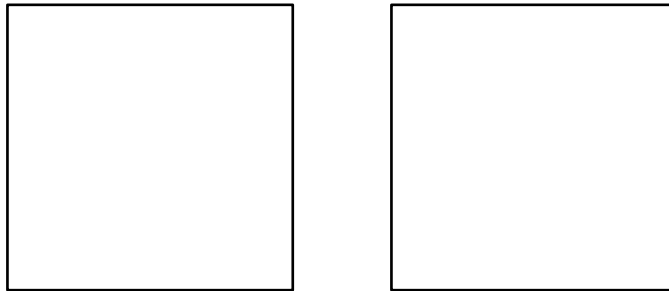

- 3 Use the grid to show sixths any way you choose.



Explain how you know you are correct.

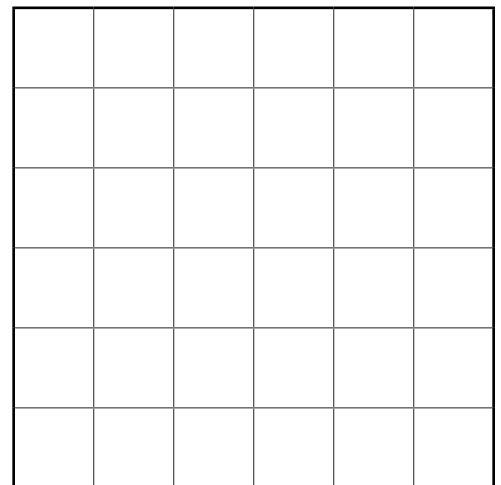

- 4 Hannah is planning a new garden area with her dad. Using the following rectangles, show 2 different ways that Hannah might partition her garden into 2 equal parts.

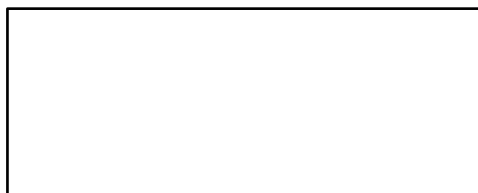

Plan #1

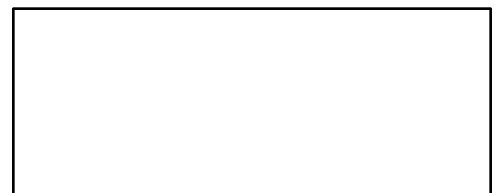

Plan #2

Name: _____

Date: _____



Analyzing the Meaning of One-Half

1 If $9 \times 8 = 72$, what is the value of $72 \div 8$?

2 Partition and shade this rectangle to show $\frac{1}{3}$ shaded.

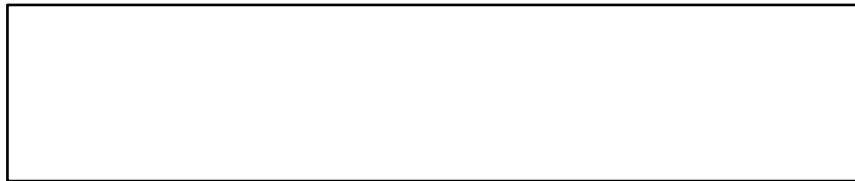

3 A lemon bar was cut like this.

Is the lemon bar cut in half?

Yes

No



Explain your thinking.



4 Aleki is selling tickets to the school's talent show where he will be playing his drum set. If each ticket costs \$5 and Aleki has collected \$45, how many tickets has he sold? Write an equation to represent the problem and solve.

Did you write an equation to explain your thinking?



Name: _____

Date: _____



Introducing the Unit Fraction

1 Is this equation true or false? $3 \times 5 = 5 \times 3$

2 Jaymie has 24 sticky notes that she splits into piles. She puts 8 sticky notes into each pile. How many piles does Jaymie make? *Draw a model to show your thinking.*

3 What fraction of each shape is shaded?

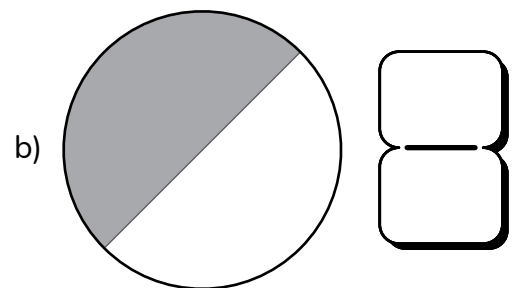
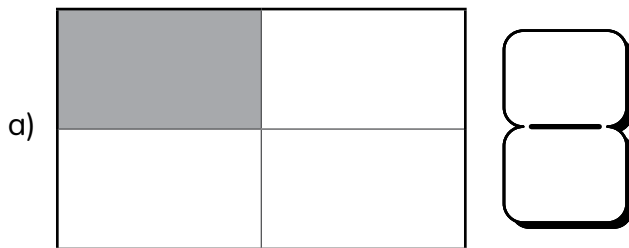

4 Arman is designing a new mosaic. He is using tiles that are $\frac{1}{8}$ of the board where the mosaic will go. How many tiles will Arman need to cover the board? Draw a model to explain your thinking.

Did you show your thinking with a model?

Name: _____

Date: _____



Vivi

Defining the Whole to Name and Iterate Unit Fractions

1 Explain how you could skip count by 4 to find the product of 3×4 .

2 What fraction of the shape is shaded?

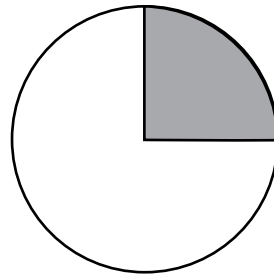

3  = 1

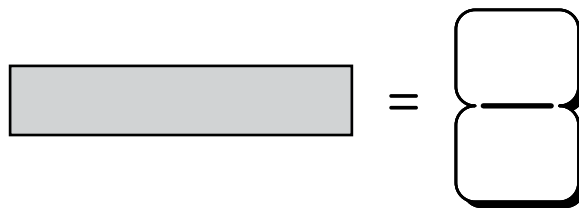

Explain your thinking.



4 Vivi is using pieces of ribbon to create a new bracelet. If each ribbon is $\frac{1}{3}$ of the bracelet, how many ribbons will Vivi need to make the whole bracelet? Draw a model to explain your thinking.

Did you show your thinking with a model?



Name: _____

Date: _____



Iterating Unit Fractions to Create Fractions

1 Solve.

$$8 \times 40 = \boxed{}$$

2 Circle the model that shows $\frac{1}{3}$ shaded.

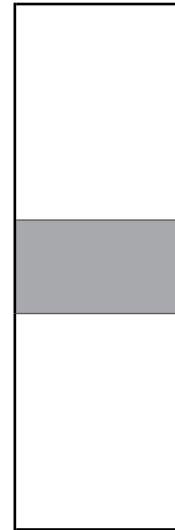

3 What fraction of each shape is shaded?

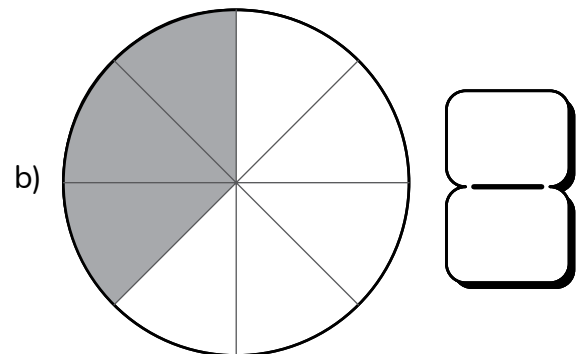
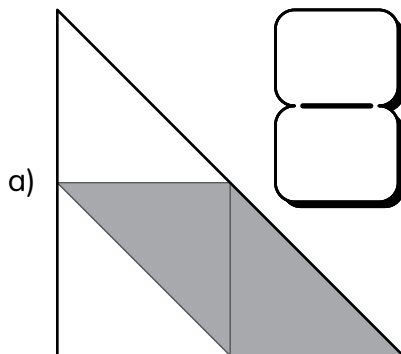

4 Hannah divided her garden into 3 equal parts. She planted strawberries in $\frac{1}{3}$ of the garden. Using the following rectangle, partition Hannah's garden and label it to show where she planted the strawberries.



Name: _____

Date: _____



Partitioning a Whole to Create Fractions

- ① What is the area of this rectangle?

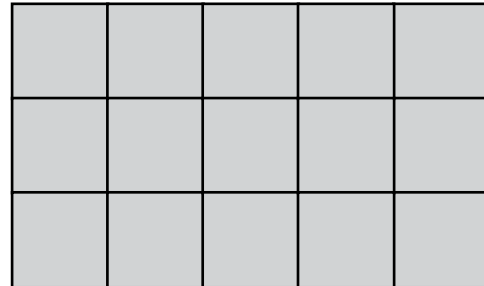

- ② Partition the rectangle into eighths and label each part with a unit fraction.

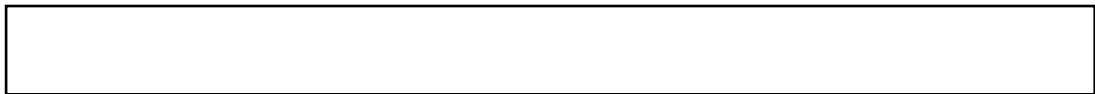

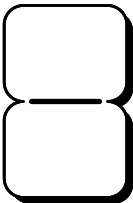
- ③ a)  of the shape is gray.

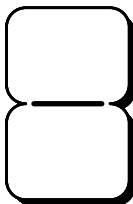
- b)  of the shape is white.



- ④ Mateo divides his canvas into 6 equal parts. He paints 2 of the parts blue and the remaining parts orange. What fraction of Mateo's painting is blue? Draw a model to explain your thinking.

Did you show your thinking with a model?



Name: _____

Date: _____



Iterating Unit Fractions to Create the Whole

- 1 Aleki says this shape is partitioned into fourths, and he knows another way to show fourths. Show another way.

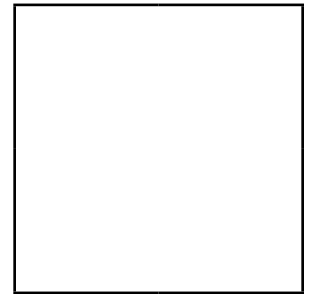
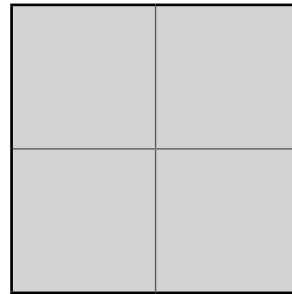

- 2 Complete the equation to represent $\frac{4}{4}$ as a sum of unit fractions.

$$\left[\begin{array}{c} \square \\ \square \end{array} \right] + \left[\begin{array}{c} \square \\ \square \end{array} \right] + \left[\begin{array}{c} \square \\ \square \end{array} \right] + \left[\begin{array}{c} \square \\ \square \end{array} \right] = \frac{4}{4}$$

- 3 Use these rectangles to show $\frac{2}{3}$ shaded in 2 different ways.



- 4 Aleki is packing bait to go fishing. He has 8 worms and 2 containers. If Aleki wants to have the same number of worms in each container, how many worms should be in each container? Write an equation to show how many worms Aleki will place in each container.

Did you show your thinking with an equation?



Name: _____

Date: _____



Decomposing and Composing Fractions with Visual Models

Louis

- ① This number is in expanded notation. Write the number in the standard form.

$$(3 \times 10,000) + (5 \times 1,000) + (8 \times 10) + (1 \times 1)$$

- ② Fill in the missing digits to make a true comparison.

$$578 > \boxed{5} \boxed{} \boxed{}$$

- ③ If this bar is $\frac{2}{8}$, show 1 whole.

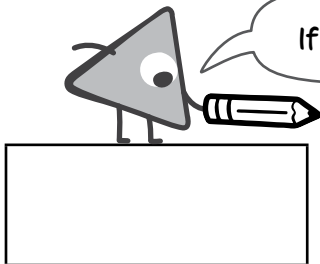

- ④ Louis's basketball team collected 464 cans in the first week. In the second week, they collected 72 more cans than they did in the first week. What was the total number of cans collected in the 2 weeks? Explain how you know.

Did you explain your thinking?



Name: _____

Date: _____



Exploring Fractions Involving Discrete Sets

- 1 Put the numbers in order from least to greatest.

10,000

1,000

100,000

- 2 Round 324 to the nearest ten.

- 3 Mateo and 2 friends equally shared 6 pupusas.

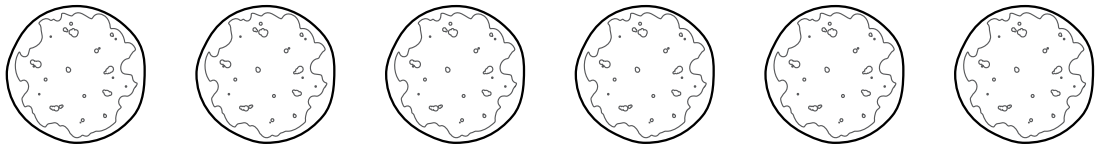

What fraction of the pupusas did each person get?

- 4 Jaymie is organizing crayons for an upcoming project. She has 8 packs of crayons with 6 crayons in each pack. How many crayons does Jaymie have? Show how you found your answer.

Did you show your thinking?



Name: _____

Date: _____



Exploring Fractions Involving Number Lines

- 1 Donner draws a rectangle with an area of 12 square centimeters. Label the possible side lengths of Donner's rectangle.

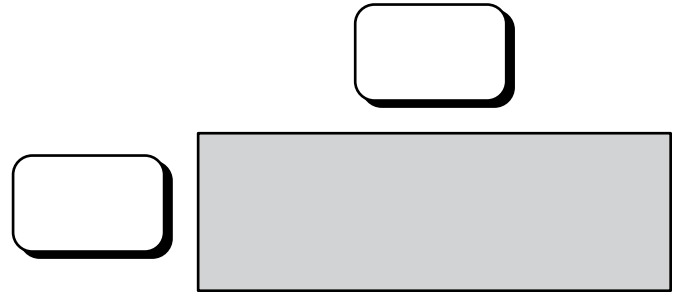

- 2 Draw 2 polygons that each have 4 vertices.



a) Label $\frac{4}{8}$ on the number line.

b) Write $\frac{4}{8}$ as a sum of unit fractions.

- 4 Vivi is making ribbon bracelets. She uses pieces of ribbon that are each 3 inches long. If she has 5 pieces of ribbon, how many inches of ribbon does she have? Write an equation to find the total length of Vivi's ribbon.

Did you show your thinking with an equation?



Name: _____

Date: _____



Donner

Locating Fractions on a Number Line

- 1 These critters shared the blocks equally. What fraction of the blocks did they each get? Show how you know.

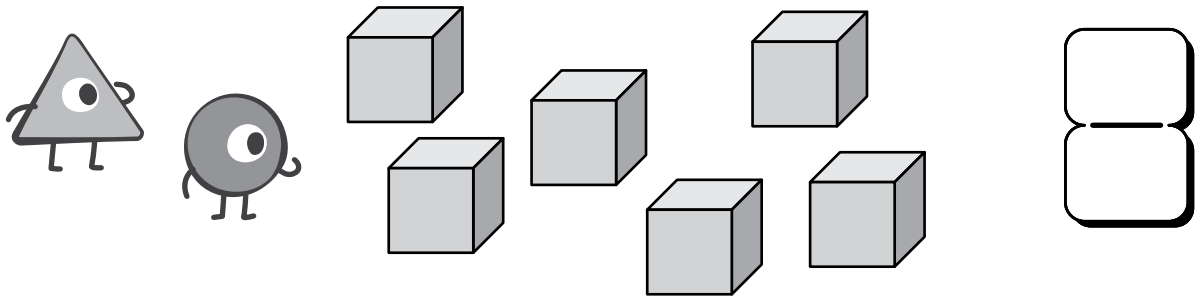

- 2 Label 1 on the number line.

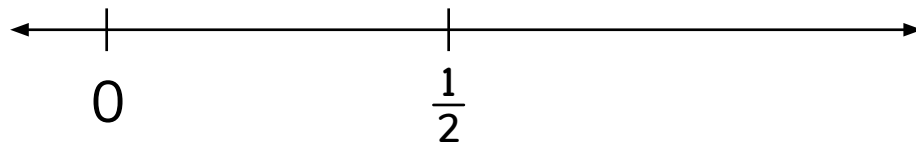

- 3 Label $\frac{2}{3}$ on the number line.

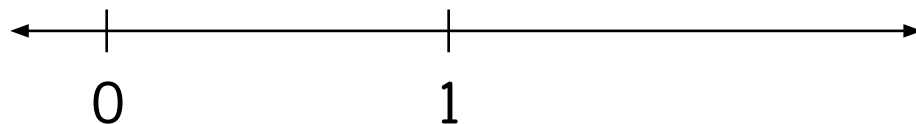

- 4 Donner is planning a hiking trip. On Friday, he plans to hike a 425-meter trail. On Saturday, he plans to hike a 250-meter trail. On Sunday, he plans to hike a 308-meter trail. How many meters does Donner plan to hike on his hiking trip in all? Solve with a strip diagram and an equation.

Did you show your thinking with a strip diagram and an equation?



Name: _____

Date: _____



Relating Different Fraction Models

① Solve. $8 \times \square = 56$

② Label $\frac{4}{8}$ on the number line.

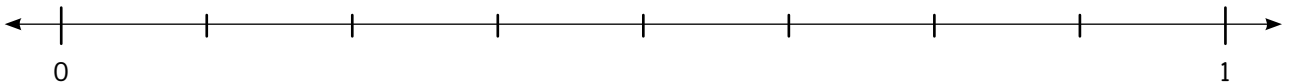

③ a) What fraction of the shape is shaded.

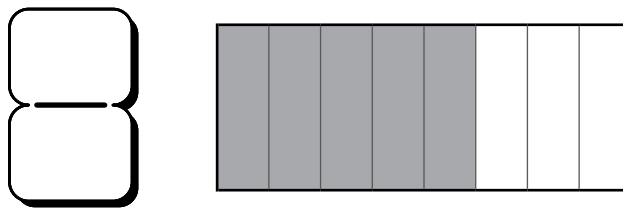

b) Write this fraction as a sum of unit fractions.

④ Hannah is planting squash in her rectangular garden. She wants to use $\frac{5}{6}$ of the garden for squash. Draw 2 different ways the squash could be planted in the rectangles below. Which plan do you think is best and why?

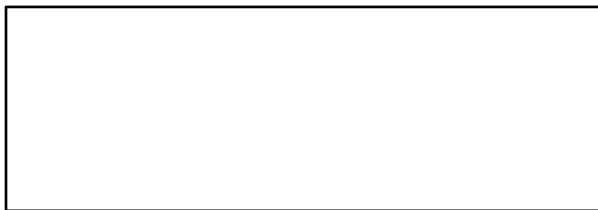

Plan #1

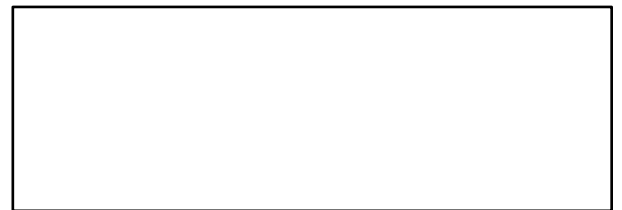

Plan #2

Topic 8

Exploring Fraction Thinking

Recommended ST Math Objectives:

Fraction Equivalence and Ordering

Fractions on the Number Line

Fraction Concepts

Name: _____

Date: _____



Writing One Whole as a Fraction

- 1 Vivi has 5 bags of marbles. There is the same number of marbles in each bag. If she has a total of 35 marbles, how many marbles are in each bag? Write an equation with a \square to represent the unknown. Solve for the unknown.

- 2 Solve.

$$48 \div 8 = \square$$

$$63 \div 7 = \square$$

- 3 Which fraction is equal to 1?

$\frac{3}{3}$

$\frac{3}{6}$

- 4

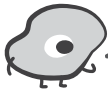

I think that $\frac{2}{2}$ and $\frac{4}{4}$ are equivalent.

Do you agree? Circle yes or no.

Yes

No

Explain your thinking.



- 5 Last year, Naomi had 465 shells in her seashell collection. When she counted them today, she had 1,000 shells. How many shells has Naomi collected since last year? Show how you found your answer.

Did you show your thinking?



Name: _____

Date: _____

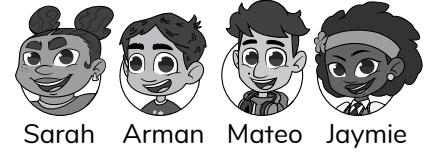

Exploring Equivalent Fractions for One-Half

1 Solve. $54 \div 6 = \square$

2 If $7 \times 8 = 56$, does $56 \div 8 = 7$? Why or why not?

3 Sarah says this rectangle shows $\frac{1}{2}$ shaded.



Arman says this rectangle shows $\frac{1}{2}$ shaded.



Who is correct? Why?

4 Partition and shade the circle to show a fraction of the circle shaded that is equivalent to $\frac{1}{2}$.

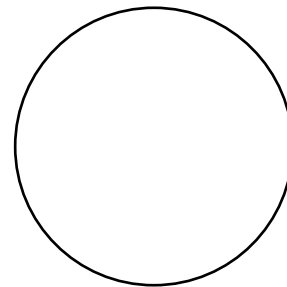

5 Mateo paints $\frac{3}{4}$ of a canvas in yellow. Jaymie paints $\frac{6}{8}$ of the same-sized canvas in yellow. Mateo says that they used the same amount of yellow paint. Do you agree? Draw a model to show your thinking.

Did you show your thinking with a model?



Name: _____

Date: _____



Using Patterns to Make Equivalent Fractions

- 1 Label the sides of the rectangle so that the rectangle has an area of 10 square meters. Then find the perimeter.

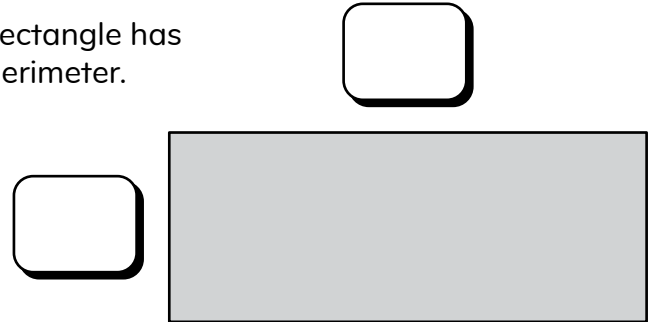

- 2 Does $\frac{1}{2} = \frac{4}{8}$? **Yes** **No**

- 3 Partition the circles to show 2 fractions that are equivalent.

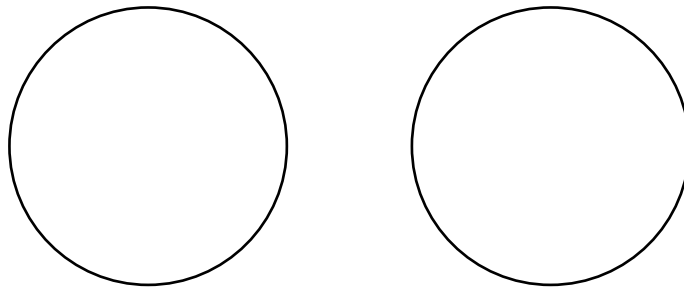

Explain how you know they are equivalent.



- 4 Mateo has 3 boxes of markers, and each box contains 8 markers. Jaymie also has 3 boxes of markers, and each box has 4 markers. Does Mateo or Jaymie have more markers? Write equations to show how you solved the problem.

Did you write equations?



Name: _____

Date: _____

Generating Equivalent Fractions on a Number Line

- ① Circle the fraction equivalent to 1.

$\frac{1}{1}$

$\frac{1}{3}$

$\frac{4}{4}$

- ② What is the area of the rectangle?

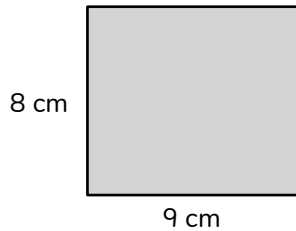

$A =$

- ③ Circle true or false and then show how you know.

$\frac{2}{8} = \frac{1}{4}$

True

False

$\frac{2}{3} = \frac{3}{6}$

True

False

- ④ The critter is holding a fraction equivalent to $\frac{6}{8}$. What could the fraction be?

Show how you know.

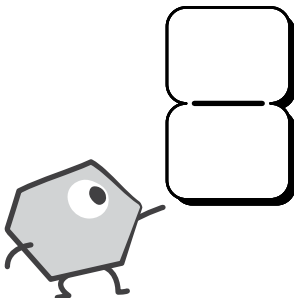

Name: _____

Date: _____

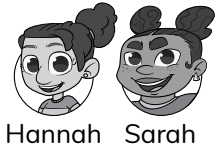

Using Equivalent Fractions to Solve Word Problems

Hannah Sarah

- 1 Circle the set of coins with a value of \$1.00.



- 2 Write 2 attributes that all rectangles share.

- 3 Hannah decides to add chives to her garden. Design her garden to add the chives while giving each plant the same amount of space.

Hannah's Garden	
$\frac{2}{6}$	of the garden bed will have onions.
$\frac{2}{6}$	of the garden bed will have garlic.

Hannah's Garden

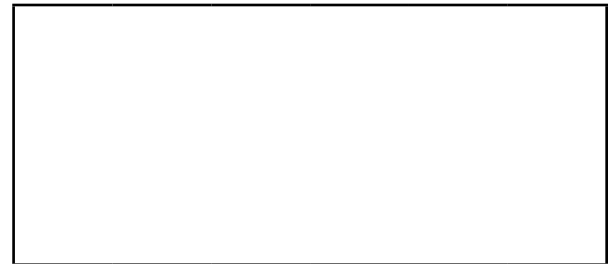

- 4 Hannah and Sarah have equal-sized vegetable gardens. Hannah plants green beans in $\frac{3}{4}$ of her vegetable garden. Sarah plants green beans in $\frac{5}{8}$ of her vegetable garden. Did Hannah and Sarah plant equivalent amounts of green beans? Draw a model to show your thinking.

Did you draw a model to show your work?



Name: _____

Date: _____



Comparing Fractions with Common Denominators

Dani

- 1 Circle the fractions equivalent to 1.

$$\frac{2}{6}$$

$$\frac{2}{2}$$

$$\frac{6}{6}$$

- 2 Partition and shade the rectangle to represent $\frac{5}{8}$ shaded.

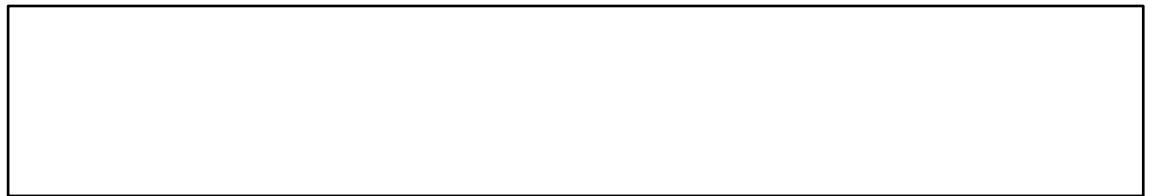

- 3 Make the comparison true. Use the models to show your thinking.

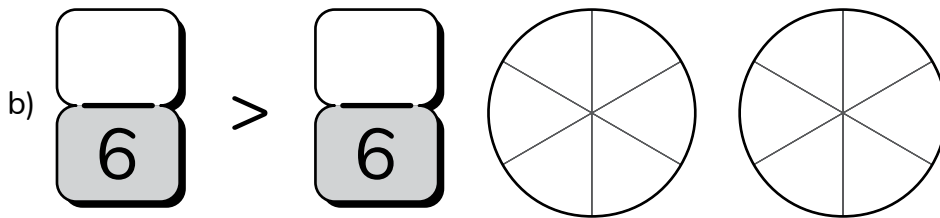
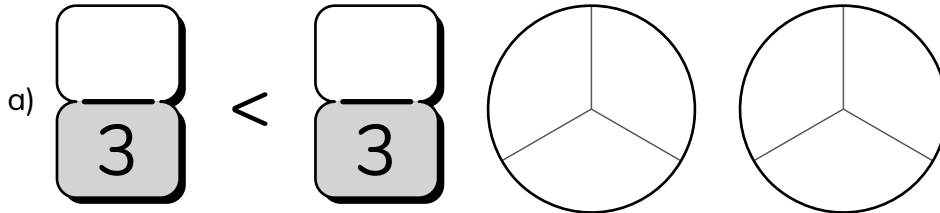

- 4 Dani used $\frac{2}{3}$ yard of wood for a project. Her brother used $\frac{1}{3}$ yard of wood for the project. Who used more wood, Dani or her brother? Explain your thinking.

Did you explain your thinking?



Name: _____

Date: _____

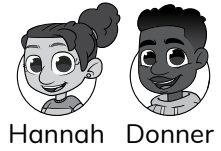

Comparing Unit Fractions

- ① Solve.

$$4 \times 8 = \square$$

$$9 \times 3 = \square$$

$$5 \times 5 = \square$$

- ② Hannah has 21 pieces of candy. If she gives the same number of pieces of candy to each of her 3 friends, how many pieces of candy will each friend get? Show your thinking.

Did you show your thinking?

- ③ Use $>$, $<$, or $=$ to make this comparison true.

$$\frac{1}{8} \quad \bigcirc \quad \frac{1}{2}$$

- ④ Why does knowing the size of the whole matter when thinking about fractions?

- ⑤ Donner hiked $\frac{1}{4}$ of a mile on Friday. On Saturday, Donner hiked $\frac{1}{3}$ of a mile. Did he hike a longer distance on Friday or Saturday? Explain your reasoning.

Did you explain your reasoning?

Name: _____

Date: _____



Comparing Fractions with Common Numerators

- ① Use $>$, $<$, or $=$ to make this comparison true.

$$\frac{1}{3} \quad \bigcirc \quad \frac{1}{4}$$

- ② Are fractions with the same denominator always equivalent? Explain.

- ③ What fraction of each circle is shaded?

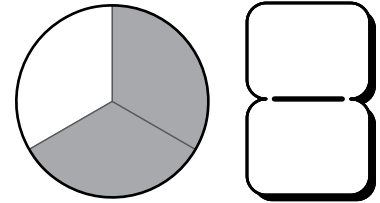
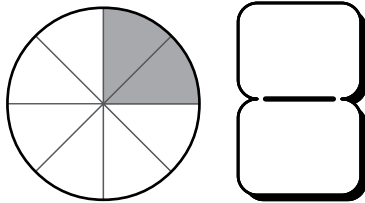

- ④ Use $>$, $<$, or $=$ to make this comparison true.

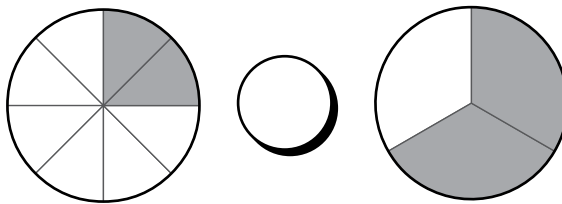

- ⑤ Aleki and his uncle went fishing. Aleki has $\frac{3}{5}$ of a bucket of worms to use for bait. His uncle has $\frac{3}{8}$ of a bucket of worms. If the buckets are the same size, does Aleki or his uncle have more worms? Explain your thinking.

Did you explain your thinking?



Name: _____

Date: _____

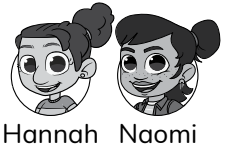

Hannah Naomi

Using Benchmarks to Order Fractions on a Number Line

- 1 Write the time shown on the clock.

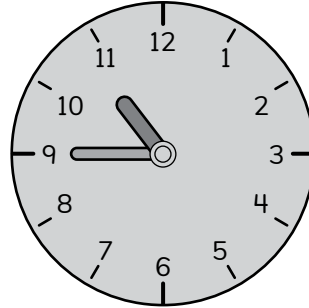

- 2 Circle the best estimate for the length of a pencil.

6 inches

6 feet

6 miles

- 3 Hannah thinks that $\frac{9}{4}$ is greater than $\frac{7}{4}$. Sarah thinks that $\frac{7}{4}$ is greater than $\frac{9}{4}$. Do you agree with Hannah or Sarah? Explain your thinking.

Did you explain your thinking?

- 4 Use $>$, $<$, or $=$ to make this comparison true.

$$\frac{1}{6} \quad \bigcirc \quad \frac{1}{2}$$

- 5 Naomi is buying food for her fish. If there are 7 fish in the tank and each fish will need 8 pellets, how many pellets will Naomi need to buy? Show how you found your answer.

Did you show your thinking?

Topic 9

Exploring Measurement

Recommended ST Math Objectives:

Time to the Minute
Intervals of Time
Weight and Volume

Name: _____

Date: _____



Measuring Length with More Precision

- ① What fraction of the figure is shaded?

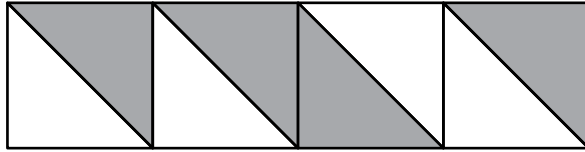

- ② Solve. $342 - 168 = \square$

③

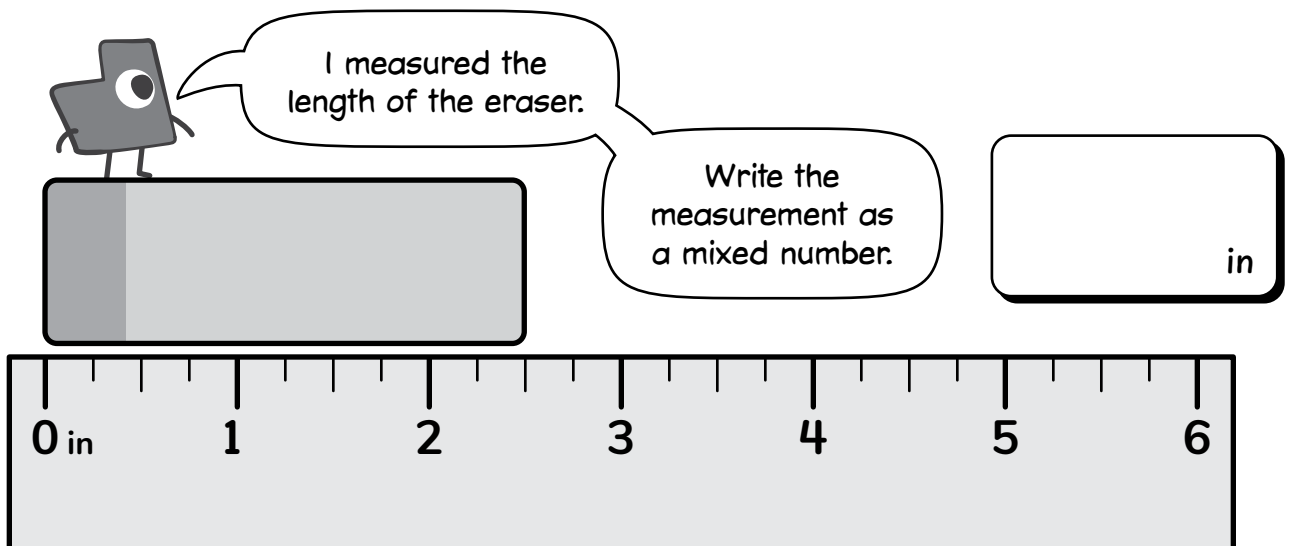

I measured the length of the eraser.

Write the measurement as a mixed number.

in

- ④ Last week, Jaymie helped in the school library. She helped to check out 209 fiction books and 98 nonfiction books. How many more fiction books were checked out than nonfiction books? Show your work with a strip diagram.

Name: _____

Date: _____



Sarah



Arman



Vivi

Strategically Comparing Fractions

- ① Solve.

$$300 - 167 = \boxed{}$$

- ② Sarah says she ate $\frac{1}{2}$ of a pizza. Arman says he ate $\frac{1}{2}$ of a pizza. The amount of pizza each child ate is NOT equal. How can this be true?

- ③ Circle true or false for each statement.

a) $\frac{1}{3}$ is greater than $\frac{1}{2}$. **True** **False**

b) $2\frac{1}{4}$ is less than $2\frac{3}{4}$. **True** **False**

c) $\frac{3}{3}$ and $\frac{8}{8}$ are equal. **True** **False**

- ④ Vivi is making necklaces. She has 36 beads and wants to use all of them. If each necklace will have the same number of beads, can she make 9 necklaces? Write an equation to show your thinking.

Did you write an equation to show your thinking?



Name: _____

Date: _____



Jaymie

Measuring Distance Traveled

- 1 Complete the statement that describes the relationship between the value of the digit in the hundreds place and the value of the digit in the tens place in the number shown.

573,111

The value of the digit in the hundreds place is **10 100** times as much as the value of the digit in the tens place.

- 2 Write 2 fractions that can represent the point on the number line.

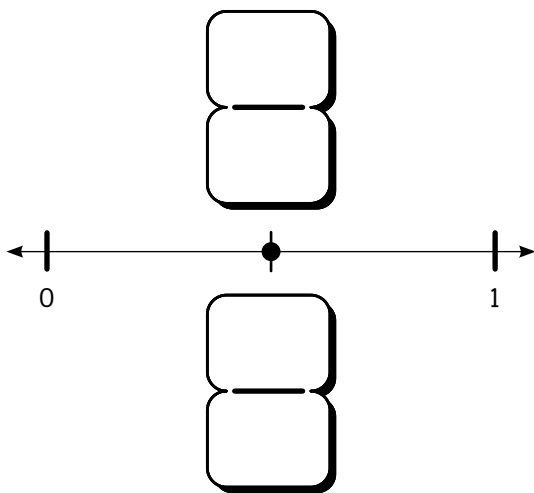

- 3

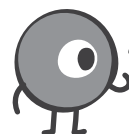

I hopped $\frac{2}{8}$ yard.

Circle the number line that represents how far I hopped.

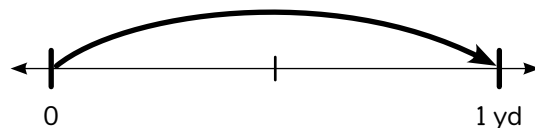
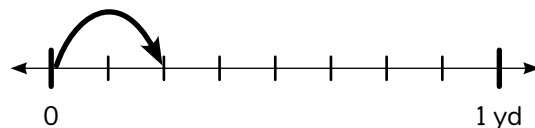
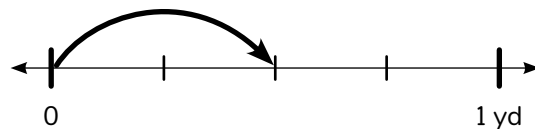

- 4 Jaymie helped her class set up chairs for the school play. They set up 8 rows of 9 chairs. Then, they placed 12 chairs along the back wall. How many total chairs did Jaymie and her class set up?

Name: _____

Date: _____



Sarah

Using a Dot Plot to Organize and Display Length Data

- 1 Label $\frac{3}{8}$ on the number line.

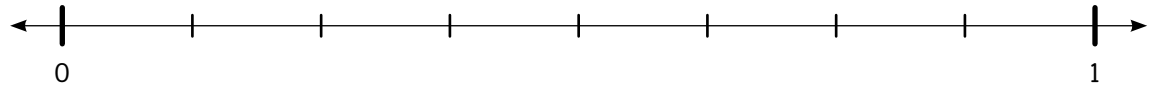

- 2 Circle the best estimate for the length of a pencil.

20 centimeters

20 meters

20 inches

- 3 **Length of Insects in Sarah's Collection**

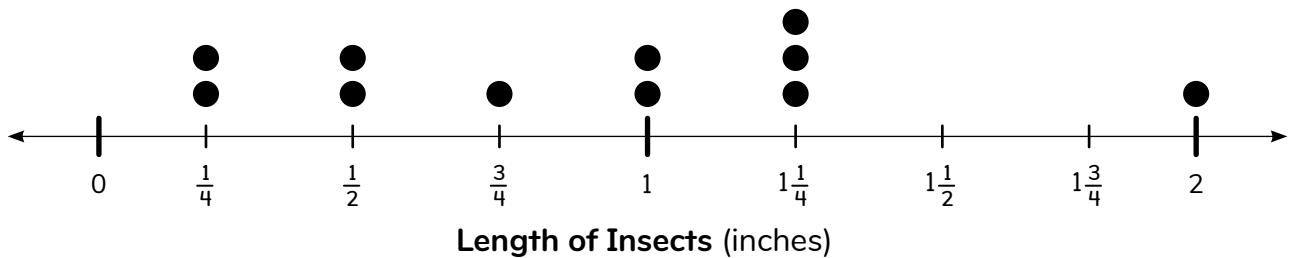

a) How many insects in Sarah's collection are less than 1 inch long?

b) What are 2 other things the dot plot tells you about Sarah's insect collection?

- 4 Sarah has 3 sets of winged insects. Each set has 7 winged insects. How many winged insects does Sarah have in her insect collection? Write an equation to show your thinking.

Did you show your thinking with an equation?



Name: _____

Date: _____



Dani



Vivi



Naomi

Using a Dot Plot to Interpret Length Data

- 1 Dani loves chocolate. Would she want to eat $\frac{3}{4}$ or $\frac{3}{8}$ of a chocolate bar? Explain your thinking?

- 2 Vivi is measuring the length of a table. Will it take more meters or centimeters to measure the length of the table? Explain your thinking.

- 3 Naomi went to the beach to collect blue mussels. She made this dot plot to show their lengths.

- a) What was the most common length of blue mussels?

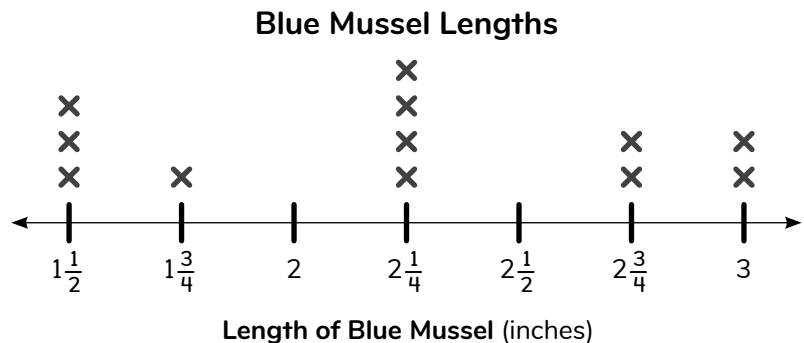

- b) How many blue mussels were longer than 2 inches?

- c) Naomi has a blue mussel that is shorter than the ones shown on the dot plot. What might be the length of Naomi's blue mussel? Explain your thinking.

Did you explain your thinking?



Name: _____

Date: _____



Collecting Length Data and Displaying on a Dot Plot

- 1 Vivi had 24 beads. She used 15 beads to make a bracelet. Then she bought 36 more beads at the store. How many beads does Vivi have now?

Show your thinking.



- 2 Write 2 different fractions that are equivalent to $\frac{1}{2}$.

- 3 **Length Across Hands of Students in Vivi's Class**

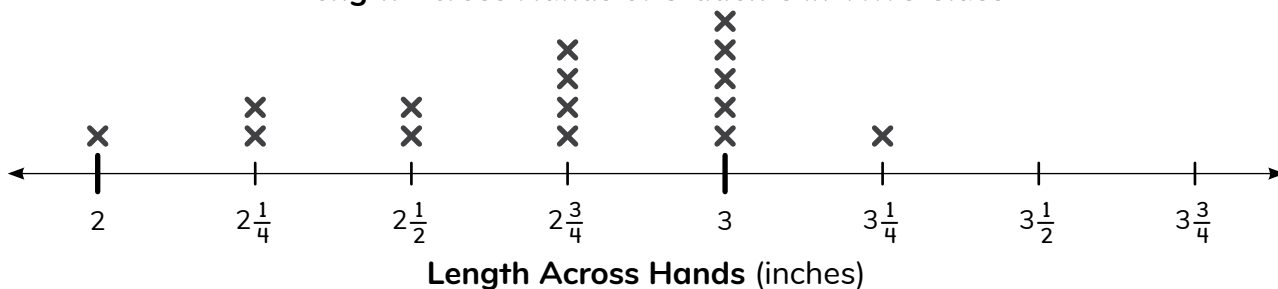

- a) Vivi and her class made this dot plot showing the lengths across their hands. Vivi said the length across the hand of most students is less than 3 inches. Do you agree with her? Explain.
- b) In the middle of the year, 2 new students joined the class. The lengths across their hands are $2\frac{1}{4}$ inches and 2 inches. Add these data points to the dot plot. Including the new students, how many students have data shown on the dot plot?
- 4 Jaymie is ordering new glue sticks for the classroom. If she wants to order 36 glue sticks and the glue sticks come in packs of 4, how many packs should she order? Show your thinking.

Did you show your work?



Name: _____

Date: _____



Mateo



Arman



Aleki

Analyzing Length Data on a Dot Plot

- 1 Solve to find the sum of the unit fractions.

$$\frac{1}{6} + \frac{1}{6} + \frac{1}{6} + \frac{1}{6} + \frac{1}{6} + \frac{1}{6} = \boxed{}$$

- 2 Mateo and Aleki collected 18 leaves for an art project. If they share the 18 leaves equally, how many leaves will they each have? Explain your thinking.

Did you explain your thinking?



3

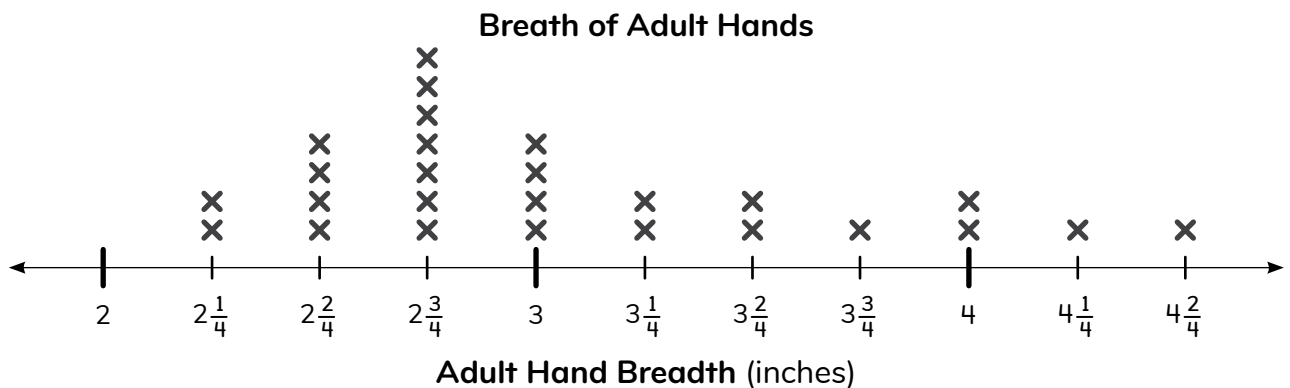

a) What was the minimum measurement?

b) How many total hands were measured?

4

The breadth of Arman's hand is $3\frac{1}{2}$ inches. The breadth of Mateo's hand is $3\frac{1}{4}$ inches. Whose hand has a larger breadth? Explain your thinking.

Did you explain your thinking?



Name: _____

Date: _____



Identifying 3-D Shapes by Their Attributes

①  = $\frac{1}{4}$

Show $\frac{3}{4}$.

Write an expression that represents your model as a sum of unit fractions.

② Write the value of 7 ten thousands, 15 hundreds, and 8 tens in standard form.

③  I built a tower using all of the shapes that have rectangular faces.

Circle the shapes I used.

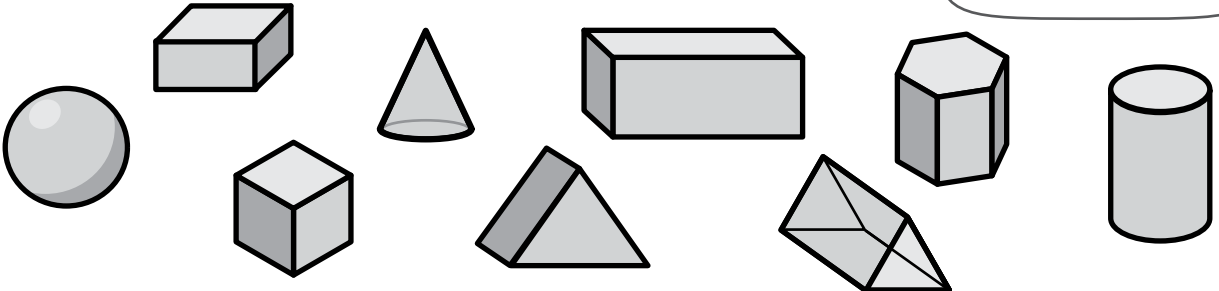

④ Donner and his aunt track birds spotted during their camping trips. In one month, they recorded 427 birds during their trips. The next month, they recorded 573 birds during their trips. How many birds did they record in total?

Did you show your thinking?



Name: _____

Date: _____



Introducing Liquid Volume

- 1 Round 36 to the nearest 10.



- 2 Donner estimates the amount of water in a glass. Is 200 liters or 200 milliliters a better estimate? Explain your thinking.

Did you explain your thinking?

- 3 What is important to do when using a graduated cylinder to measure volume?

- 4 Dani and Sarah filled up two cups with water. Dani's cup had a volume of 250 mL and Sarah's cup had a volume of 375 mL. How much more water did Sarah's cup have? Show your thinking.

Did you show your thinking?

- 5 Naomi is adding water to her aquarium. She measures about 175 mL of water. Is the amount Naomi measured closer to 170 mL or 180 mL? Explain your thinking.

Did you explain your thinking?

Name: _____

Date: _____



Solving Problems Involving Liquid Volume

- 1 Does a polygon always have the same number of sides as it has vertices?
Explain your reasoning.

Did you explain your reasoning?



2 Solve. $704 - 285 = \square$

- 3 Naomi bought this fish tank that holds 20 L of water.



- a) Which fish should Naomi put in the tank?
Show your thinking.

Type of Fish	Water Needed (L)
 Cory Catfish	8
 Neon Tetra	4
 Platy	8
 Zebra Danio	2

- b) Could Naomi put all the fish in the tank and each fish have the water they need?
Explain why or why not.

- 4 Vivi is measuring ribbon for a new project. She has 24 feet of ribbon and wants to cut the ribbon into 3-foot sections. How many pieces of ribbon can Vivi cut?
Make a model to show how you found your answer.

Did you show your thinking with a model?



Name: _____

Date: _____



Introducing Liquid Volume in Customary Units

- 1 Complete the statement that describes the relationship between the value of the digit in the thousands place and the value of the digit in the tens place in the number shown.

842,128

The value of the digit in the thousands place is **2 10 100** times as much as the value of the digit in the tens place.

- 2 Make the comparison true. $1,783 > \boxed{} > 1,684$

3

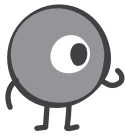

Which unit should we use to measure how much liquid is in this pitcher?

Why?



4

Arman measured the side lengths of the rectangular hallway floor outside his classroom. The floor had side lengths of 28 feet and 9 feet.

a) What is the area of the hallway floor?

b) What is the perimeter of the hallway floor?

Name: _____

Date: _____



Hannah

Introducing Weight

- ① Solve.

$$8 \times 40 = \square$$

- ② Use $<$, $>$, or $=$ to make the comparison true.

$$10,000 \bigcirc 100,000$$

- ③ What is important to do when using a balance to weigh objects?

- ④ If a glue bottle weighs 4 ounces, what is the weight of the book? Explain your thinking.

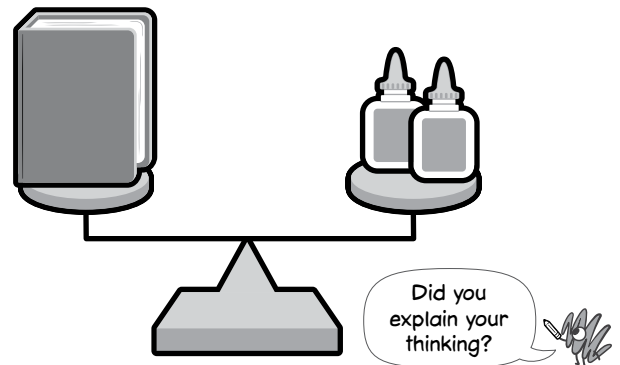

- ⑤ Hannah has 2 watermelons. The first watermelon weighs 193 ounces. The second watermelon weighs 250 ounces. What is the difference in weight between the 2 watermelons? Write an equation to show your thinking.

Did you show your thinking with an equation?

Name: _____

Date: _____



Vivi



Mateo



Naomi

Estimating and Solving Measurement Problems in Context

- 1 Find the perimeter of the rectangle.

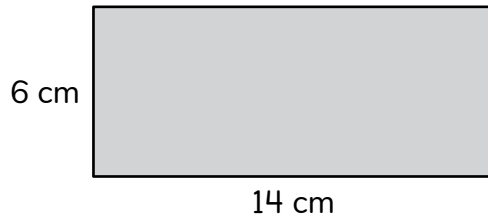

$$P = \boxed{}$$

- 2 What sign would make this comparison true?
Show how you know.

$$\frac{3}{4} \bigcirc \frac{2}{4}$$

- 3 Vivi collected green beans from her garden. Which unit of measurement should she use to measure the weight of the green beans?

quarts

ounces

gallons

- 4 Mateo gives his dog Arturito the same amount of water in his dish each day. Which unit of measurement should Mateo use to measure the amount of water in Arturito's dish?

ounces

yards

fluid ounces

- 5 Naomi put 56 shells in 8 jars. She put the same number of shells in each jar. How many shells did Naomi put in each jar? Show your thinking with a strip diagram.

Name: _____

Date: _____



Using Tables to Represent Additive and Multiplicative Measurement Relationships

- ① Label $\frac{4}{6}$ on the number line.



- ② What number is equivalent to this expression? $400 + 20,000 + 10 + 6$

- ③ There are 3 glue sticks in each package sold at the store. Complete the table to show the total number of glue sticks in each number of packages.

Number of Glue Sticks in Different Numbers of Packages

Number of Packages	Total Number of Glue Sticks
5	15
7	21
9	
11	
12	

- ④ Aleki helped sell tickets for his school band concert. There were 620 tickets. At the end of the week, 95 tickets were left. How many tickets were sold?

Topic 10

Deepening Financial Literacy

Recommended ST Math Objectives:

Money with Coins and Bills

Addition and Subtraction within 1000 Strategies

Solve Two-Step Problems

Name: _____

Date: _____



Representing a Given Amount with Coins and Bills

Mateo

- 1 Compare the fractions shown as points on the number line.

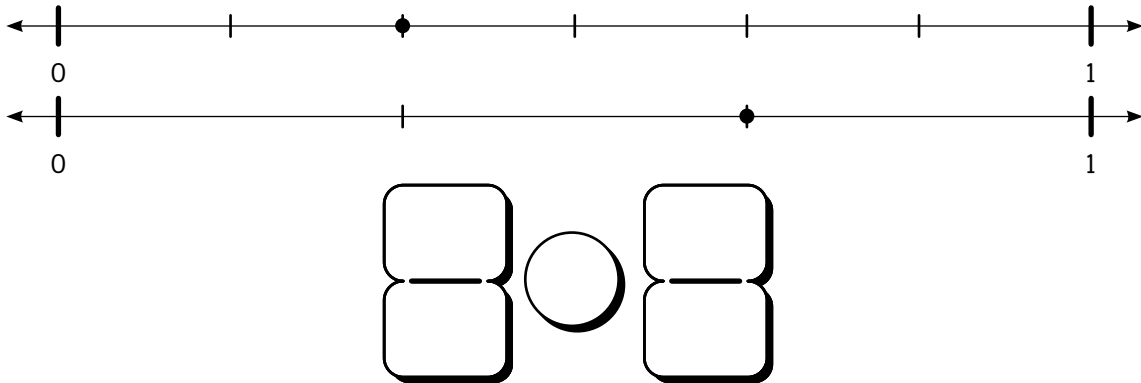

2 $48 \div \square = 6$

- 3 Circle the coins and bills that can be used to make \$12.30.

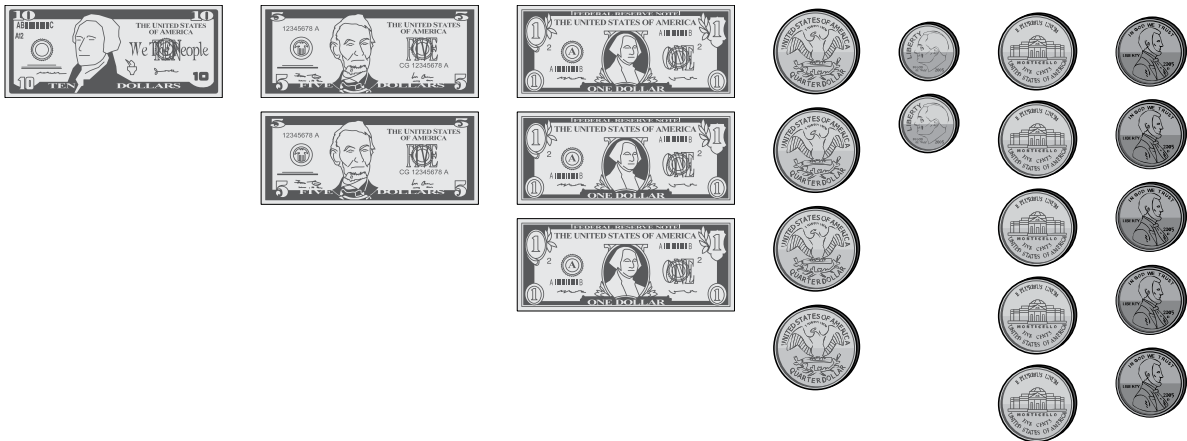

- 4 Mateo's dog Arturito eats $\frac{5}{6}$ of a bag of dog food every month. Write this fraction as a sum of unit fractions.

Name: _____

Date: _____

Solving Addition and Comparison Problems with Money

- 1 What is the area of the shaded figure?

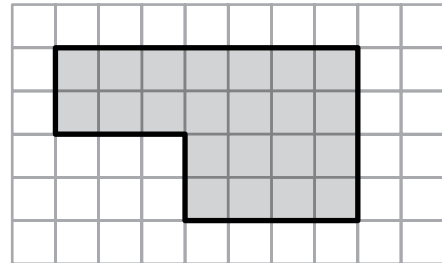

- 2 Order the numbers from greatest to least.

8,197 42,056 8,735

- 3  This is how much money I had.

Then, I was given two \$1 bills and three \$5 bills. How much money do I have now?



- 4 Last month, Hannah and her dad planted 9 rows of flowers. Each row had 27 flowers. How many flowers did they plant?

Name: _____

Date: _____



Solving Subtraction Problems by Making Change

1

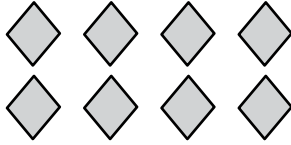

a) Write a multiplication equation to represent the model.

b) Write a repeated-addition equation to represent the model.

2

$$401 - 153 = \square$$

3

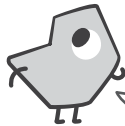

I want to buy something that costs \$18.

I pay with one \$10 bill and two \$5 bills.
How much change will I get?

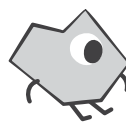

What bills would I get back?

4

Jaymie had 96 books to put on shelves. She placed 12 books on each shelf.
How many shelves did she use?

Name: _____

Date: _____



Dani

Identifying Factors that Affect Income

- ① The perimeter of the triangle is 42 centimeters.
Find the missing side length.

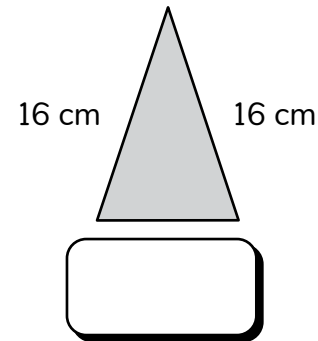

What number could the point represent?

- ③ What factors can increase a person's income?

- ④ Dani has a collection of nails and screws in her toolbox. She has 319 nails and 187 screws. How many more nails than screws does Dani have? Show your thinking with a strip diagram.

Name: _____

Date: _____



Jaymie



Vivi

Identifying Benefits and Strategies for Saving Money

- ① Circle the odd numbers.

30 15 122 7 48 54 261

② $\times 6 = 54$

- ③ Jaymie wants to buy a new tablet case that costs \$45. She has already saved \$15, and she deposits \$8 into her bank account each week. How many weeks will it take Jaymie to save \$45? Explain your thinking.

	Week 1	Week 2	Week 3	Week 4	Week 5	Week 6
Deposit	\$8					
Total Money	\$23					

- ④ Vivi bought a new square sticker album. The perimeter of the album is 36 inches. What is the length of each side of the sticker album in inches?



Name: _____

Date: _____



Exploring Responsible Credit Use and Paying Interest

- 1 Match the standard form of each number to its expanded notation.

100,000	$(1 \times 10,000) + (1 \times 10)$
10,010	$(1 \times 1,000) + (1 \times 100) + (1 \times 1)$
1,101	$(1 \times 100,000)$

- 2 Complete the chart to show when someone might save or might use credit for each activity.

Activity	Save	Use Credit
buying a game	✓	
paying for a haircut		
buying a house		
donating to a charity		
going to the doctor		

I did one for you!



Choose 1 activity and explain why someone might save or might use credit.

- 3 Brian brought 9 pizzas to the party. Each pizza had 8 slices. How many slices of pizza did Brian bring to the party? Solve with an equation.

Did you solve with an equation?



Name: _____

Date: _____



Exploring Decisions About Planned and Unplanned Uses of Money

Jaymie

- 1 Which equations match the model? Circle your answers.

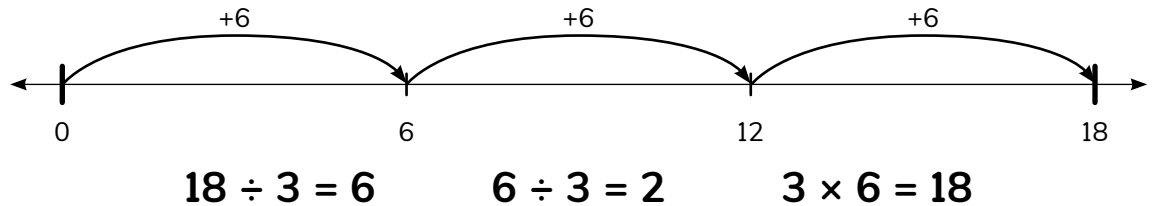

2

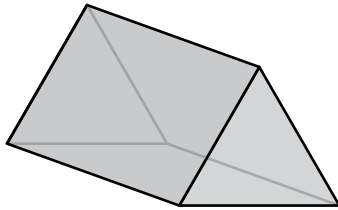

How many faces?

How many vertices?

How many edges?

What is the shape of the base?

What is the name of the shape?

3

Identify each example as a planned or unplanned spending decision.

I did one for you!



Example	Planned	Unplanned
paying for a haircut	✓	
fixing a broken car		
donating money outside of a store		
saving up for a new outfit		
paying for art classes		

4

Jaymie had some money. She bought items that cost a total of \$31 and got \$9 back in change. How much money did Jaymie start with?

Name: _____

Date: _____



Exploring How Availability Affects the Price of Resources

① Round 247 to the nearest 10.

Round 247 to the nearest 100.

② If $6 \times 4 = 24$, what is the value of $24 \div 6$?

③ The table below shows the number of pies that are available to sell at the farmers market each month.

Number of Pies Available to Sell Each Month

Month	Number of Pies
September	35
October	52
November	40

In which month will the price of the pies be the lowest? Explain your thinking.

Did you explain your thinking?

④ If Mateo has 50 pencils, could the pencils come in packs of 5? Show your work.

Did you show your work?

Topic 11

Investigating Data

Recommended ST Math Objectives:

Line Plots

Scale and Measurement in Graphing

Number Patterns

Name: _____

Date: _____



Starting a Data Investigation

1 Finish each statement.

a) 454 rounded to the nearest ten is .

b) 454 rounded to the nearest hundred is .

2 Use $>$, $<$, or $=$ to make this comparison true.

$$\frac{2}{4} \quad \bigcirc \quad \frac{2}{8}$$

3 Aleki peeked in his bag and saw that he had 10 candies that were either green, red, or purple. There were 6 red candies. There were more purple candies than green. How many green candies were there? Draw a model to show your thinking.

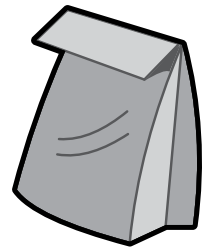

Did you show your thinking with a model?

4 Naomi observed 42 shells in her recent visit to the tide pool. If she wants to organize information about them equally into 7 pages of her notebook, how many shells should she write about on each page? Write an equation to show your thinking.

Did you show your thinking?

Name: _____

Date: _____



Naomi

Completing a Data Investigation

- 1 Naomi has 8 liters of fruit punch. How many 2-liter pitchers can Naomi fill with fruit punch? Show your thinking.

Did you show your thinking?

- 2 Continue the pattern.

7, 14, 21, 28,



- 3 a) How many shapes are either stars or circles?

Number of Shapes by Shape in the Game

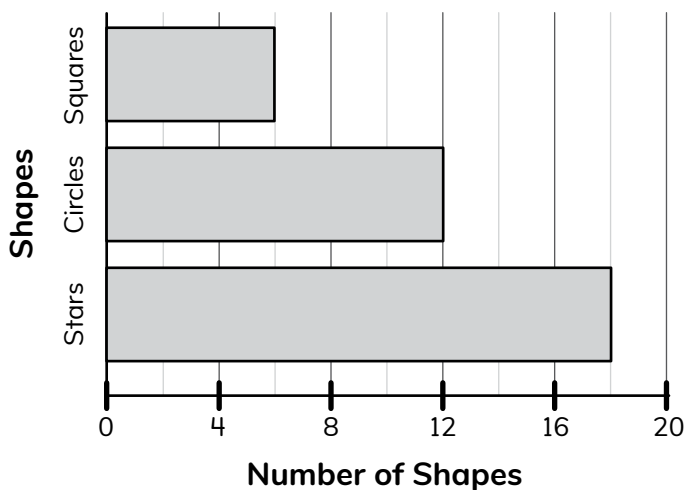

- b) How many total shapes are shown on the graph?

- 4 Naomi has 2 notebooks full of information about fish that she has seen at the tide pools. She knows she has written about 802 fish. Her first notebook has information about 347 fish. How many fish has she written about in her second notebook? Write an equation to show your thinking.

Did you show your thinking with an equation?

Name: _____

Date: _____



Revisiting a Data Investigation

- 1 What time does the clock show?

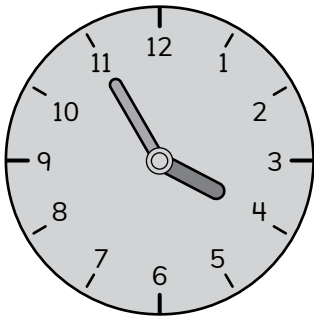

- 2 Solve.

$$482 + 379 = \boxed{}$$

- 3 Hannah pulled out her inch tiles. She organized them in a chart.

Red	5
Blue	8
Green	14
Yellow	3

Create a bar graph to show the colors of the inch tiles in Hannah's bag.



- 4 Aleki stays after school to practice the drums. He plays 4 practice sets. If each set is the same length and he plays for 36 minutes, what is the length of each practice set? Show your thinking.



Did you show your thinking?



Name: _____

Date: _____



Using Surveys to Collect and Display Data in Scaled Bar Graphs

Vivi

- 1 Partition and shade the rectangle to show $\frac{6}{8}$ shaded.



- 2 Label $\frac{3}{4}$ on the number line.



- 3 The third grade students took a poll to see which Jiji they like best.

a) How many more students like Astronaut Jiji than Basketball Jiji?

b) How many students voted for their favorite Jiji?



Third Grade Students' Favorite Jiji

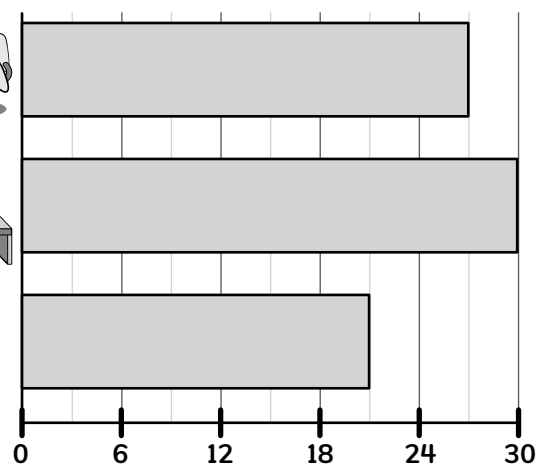

- 4 Vivi is cutting ribbon for a new bracelet. She cuts $\frac{1}{6}$ inch of red ribbon and $\frac{5}{6}$ inch of orange ribbon. Does she have more red ribbon or more orange ribbon? Explain your reasoning.

Did you explain your reasoning?



Name: _____

Date: _____



Collecting Survey Data to Display in Scaled Pictographs and Bar Graphs

Mateo

Jaymie

1

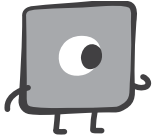

I drew a square with a perimeter of 28 inches.
What are the side lengths of my square?

Show your thinking
with an equation.

2

Mateo rolled a number cube and recorded the results on the dot plot below.

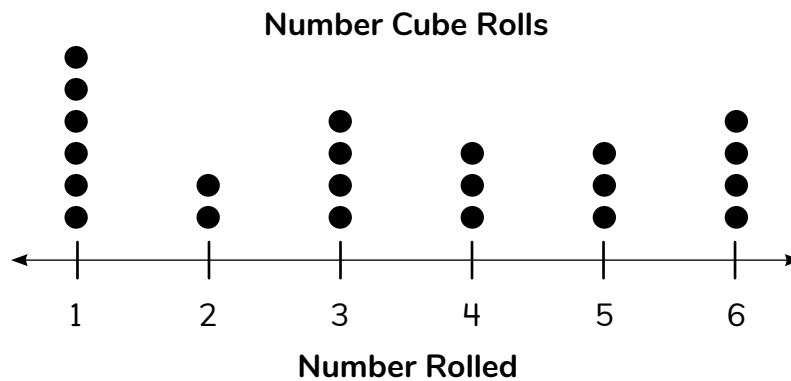

a) How many times did Mateo roll the number 4?

b) How many times did Mateo roll the number cube in all?

3

Jaymie is ordering school supplies for next year. She orders 8 boxes of crayons. Each box contains 6 crayons. How many crayons does Jaymie order? Show your thinking.

Did you show
your thinking?

Name: _____

Date: _____

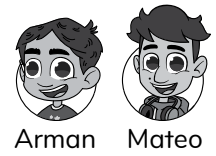





Displaying Survey Data in Scaled Pictographs and Bar Graphs

1 Arman measured 216 mL of apple juice and 306 mL of cranberry juice to make a fruit punch. What is the total volume of Arman's fruit punch?

2 How are a bar graph and dot plot the same? How are they different?

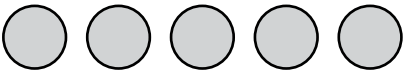
3 a) How many total student votes are represented on the graph? Show your thinking.

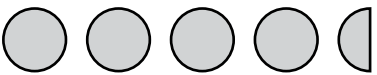
Students' Preferred Insects

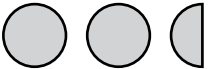
Type of Insect	Number of Student Votes
	
	
	

b) How many more students prefer butterflies than bees?

Key:  = 4 insects

4 Arman and Mateo are making paintings that are the same size. Arman painted $\frac{4}{5}$ of his painting red, and Mateo painted $\frac{4}{6}$ of his painting red. Whose painting has more red?

Name: _____

Date: _____



Jaymie



Donner



Mateo

Interpreting Scaled Pictographs and Bar Graphs to Solve One- and Two-Step Problems

- 1 Continue the pattern.

27, 36, 45, , ,

- 2 Jaymie had 300 flyers to advertise her lemonade stand. She handed out some flyers around town. Now she has 134 flyers. How many flyers did Jaymie hand out?

- 3 Donner recorded the amount of rainfall his town received each day for 2 weeks in the frequency table below. Use this data to complete the dot plot.

**Inches of Rainfall
Each Day for 2 Weeks**

Rain (in)	Number of Days
0	5
$\frac{1}{2}$	3
1	4
$1\frac{1}{2}$	1
2	1

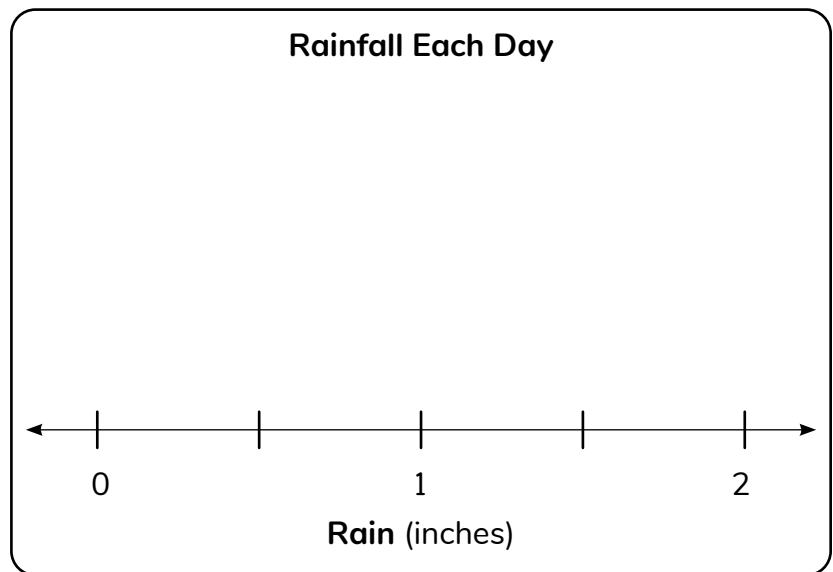

- 4 Mateo counts steps on his step tracker when he walks his dog, Arturito. His goal is to walk his dog 1,000 steps each day. If he walks 350 steps around his block, and then 215 steps to the park, how many more steps does Mateo need to walk to reach his goal?

Did you show your thinking?



Name: _____

Date: _____



Vivi



Naomi



Sarah

Relating Analog Clocks, Number Lines, and Time

- 1 Circle the activity that would take the most time to complete.

**blowing out
a candle**

**brushing
your teeth**

**making
a cake**

- 2 Read the analog clock.
Write the time shown on
the digital clock.

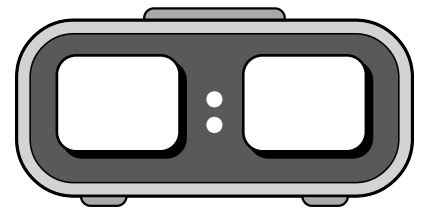
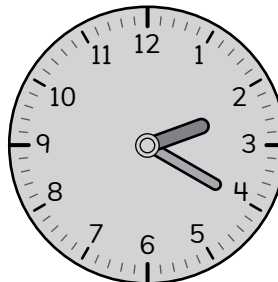

- 3 Vivi and her family threw a party. The party began at 5:00 p.m. and lasted 2 hours and 45 minutes. Show the time the party ended using the number line.

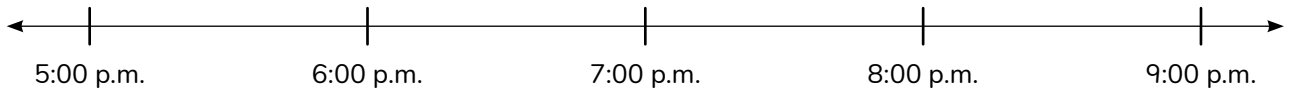

- 4 Naomi went to the tide pool to see if she could find any new fish to write about. She was at the tide pool for 1 hour and 20 minutes. She left the tide pool at 3:00 p.m. What time did she arrive at the tide pool? Draw a model to explain your thinking.

Did you draw a model
to explain your thinking?



- 5 Sarah has a butterfly, a cricket, and a praying mantis in her insect collection. Each insect has 6 legs. What is the total number of legs for these insects? Write an equation to explain your thinking.

Did you write an equation
to explain your thinking?



Name: _____

Date: _____



Modeling and Solving Word Problems Involving Time

1

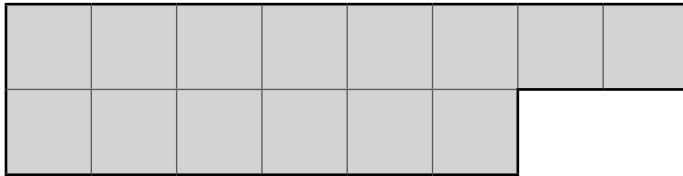

Find the area of this shape.

2

Read the analog clock. Write the time shown on the digital clock.

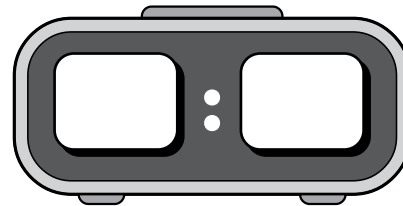
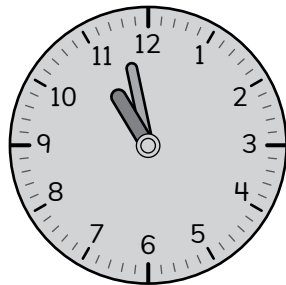

3

Donner practiced his violin for 20 minutes in the morning, 22 minutes in the afternoon, and 28 minutes in the evening. What is the total amount of time Donner practiced his violin?

4

Hannah ran a race with her sister. They both started running at 10:00 a.m. Hannah finished the race in 55 minutes. Her sister finished 8 minutes before Hannah. What time did Hannah's sister finish the race?



ST Math
Texas



MIND
EDUCATION®

© 2026 MIND Education®. All Rights Reserved.